

Commercial Leasing Office  
2828 Pickett Rd, Suite 120  
Durham, NC 27705  
Ph: 919-484-1053  
Fax: 919-484-1996  
www.ticonproperties.com  
brent@ticonproperties.com



## **2828 Picket Road Office Space for Lease**

- **\$22.00 - \$32.00 PSF**
- **Second floor office space with elevator**
- **Electricity and Water included**
- **Tenant responsible for phone/internet and janitorial**
- **3% annual rent increases**
- **3 year lease term minimum**
- **15% Core Factor**
- **Personal Guarantor required**

INFORMATION HEREIN IS SUBJECT TO VERIFICATION BY ALL PARTIES AND MAY CHANGE WITHOUT NOTICE. PLANS NOT TO SCALE; FOR GENERAL APPROXIMATION ONLY; SUBJECT TO CHANGE, REVISION, OMISSION AT ANY TIME.

**Location:  
2828 Pickett Road  
Durham, NC 27705**

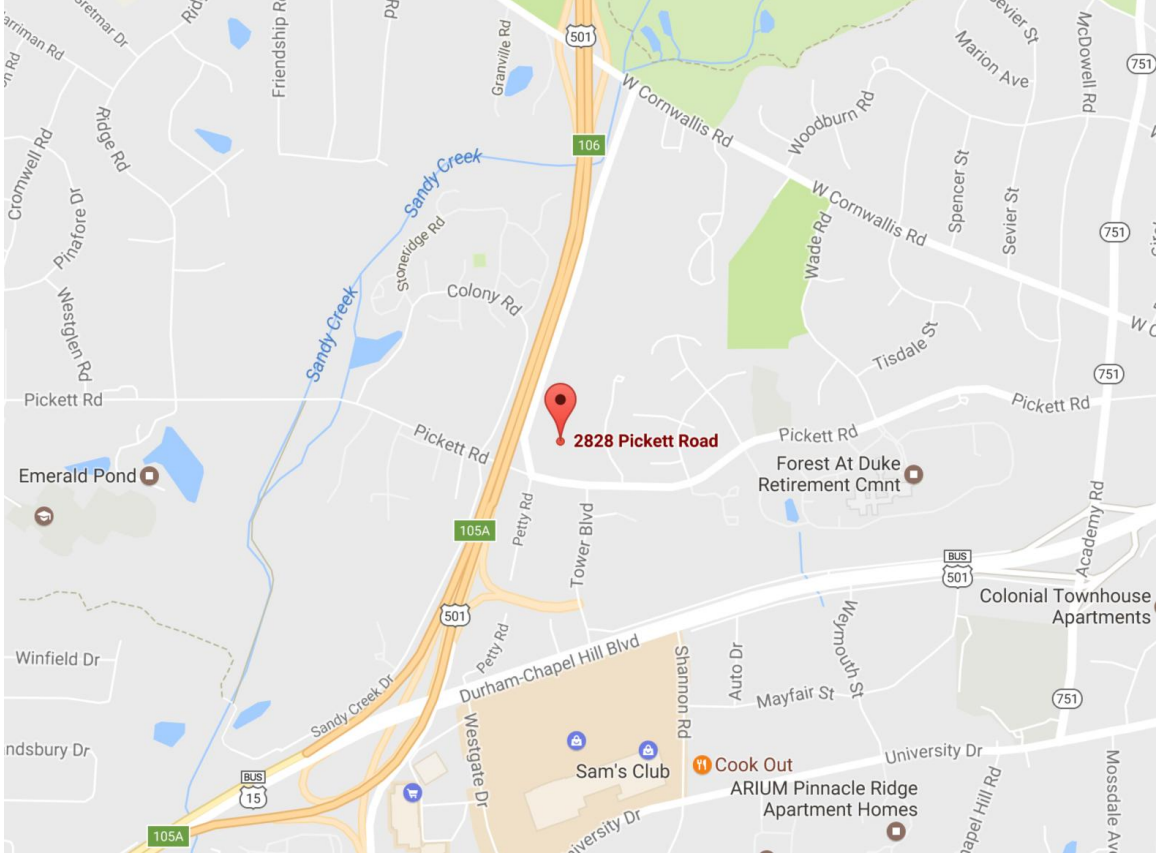

INFORMATION HEREIN IS SUBJECT TO VERIFICATION BY ALL PARTIES AND MAY CHANGE WITHOUT NOTICE. PLANS NOT TO SCALE; FOR GENERAL APPROXIMATION ONLY; SUBJECT TO CHANGE, REVISION, OMISSION AT ANY TIME.

# Site Plan

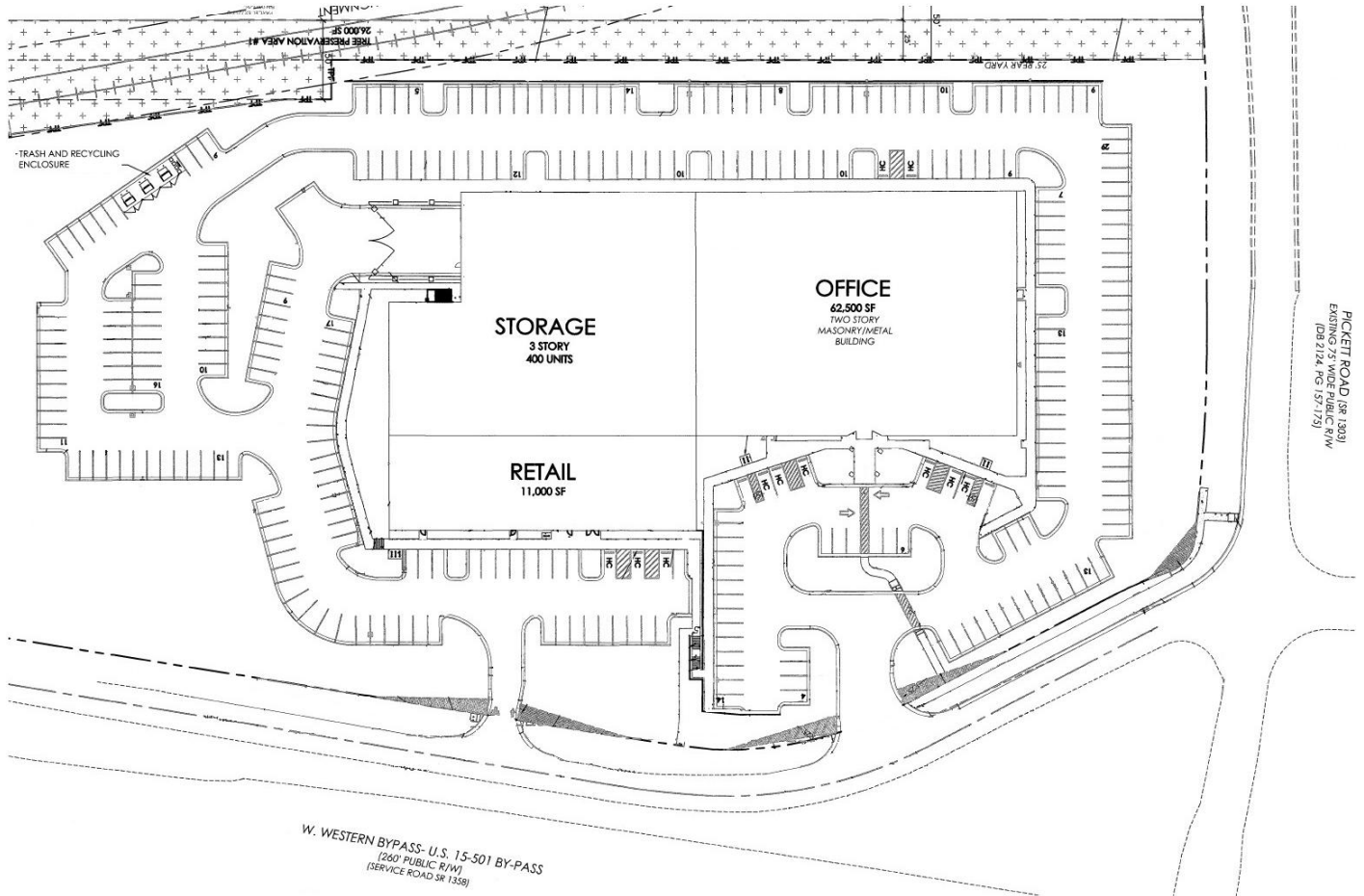

INFORMATION HEREIN IS SUBJECT TO VERIFICATION BY ALL PARTIES AND MAY CHANGE WITHOUT NOTICE. PLANS NOT TO SCALE; FOR GENERAL APPROXIMATION ONLY; SUBJECT TO CHANGE, REVISION, OMISSION AT ANY TIME.

## Second Floor

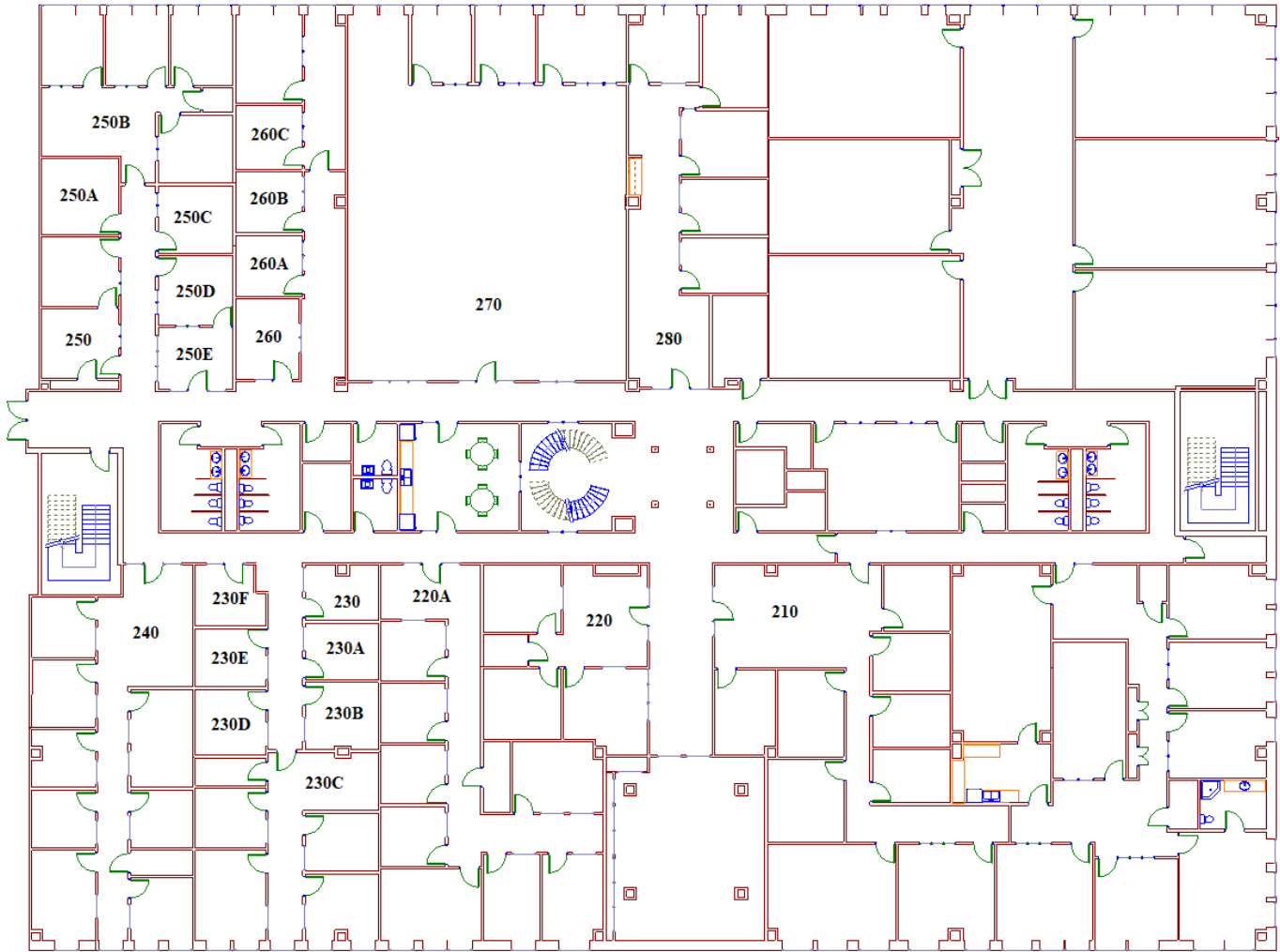

Suite	Useable SF	Rentable SF	Rate	Monthly Rent	Available
220	820	943	\$ 22.00	\$ 1,728.83	NOW
230	117	135	\$ 31.11	\$ 350.00	NOW
230A	119	137	\$ 30.66	\$ 350.00	NOW
230B	140	161	\$ 26.09	\$ 350.00	NOW
230D	134	154	\$ 27.27	\$ 350.00	NOW
230E	118	136	\$ 30.88	\$ 350.00	NOW
230F	117	135	\$ 31.11	\$ 350.00	NOW
260	146	168	\$ 25.00	\$ 350.00	NOW
260A	118	136	\$ 30.88	\$ 350.00	NOW
270	2818	3241	\$ 22.00	\$ 5,941.83	3-6 months

INFORMATION HEREIN IS SUBJECT TO VERIFICATION BY ALL PARTIES AND MAY CHANGE WITHOUT NOTICE. PLANS NOT TO SCALE; FOR GENERAL APPROXIMATION ONLY; SUBJECT TO CHANGE, REVISION, OMISSION AT ANY TIME.

# Suite 220

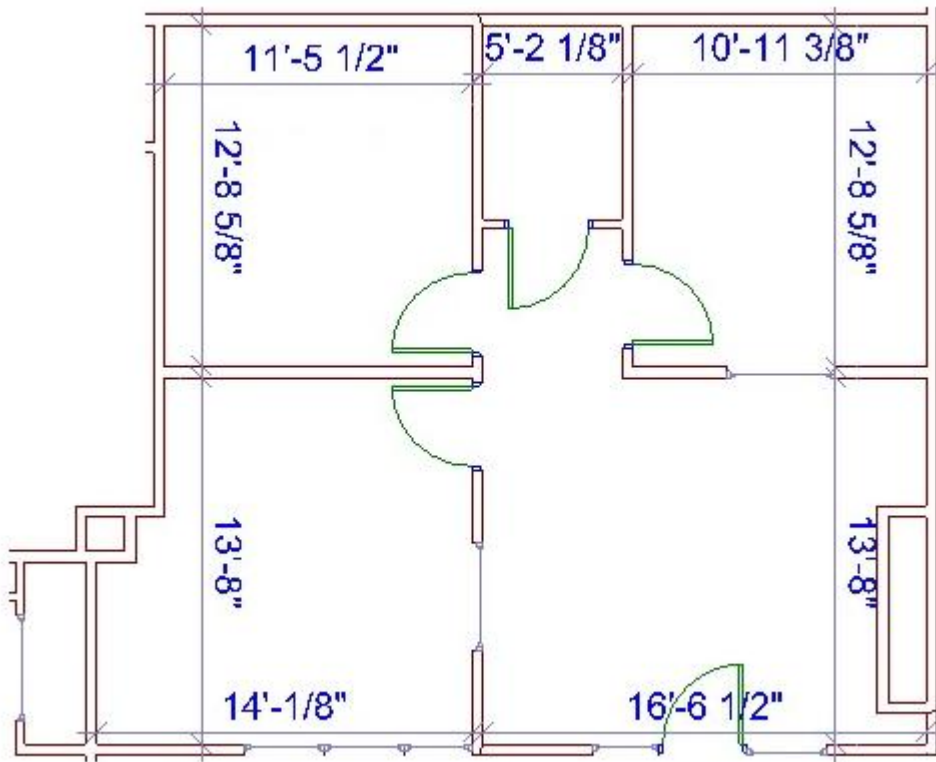

INFORMATION HEREIN IS SUBJECT TO VERIFICATION BY ALL PARTIES AND MAY CHANGE WITHOUT NOTICE. PLANS NOT TO SCALE; FOR GENERAL APPROXIMATION ONLY; SUBJECT TO CHANGE, REVISION, OMISSION AT ANY TIME.

**Suites 230-230F**  
**Single office spaces**

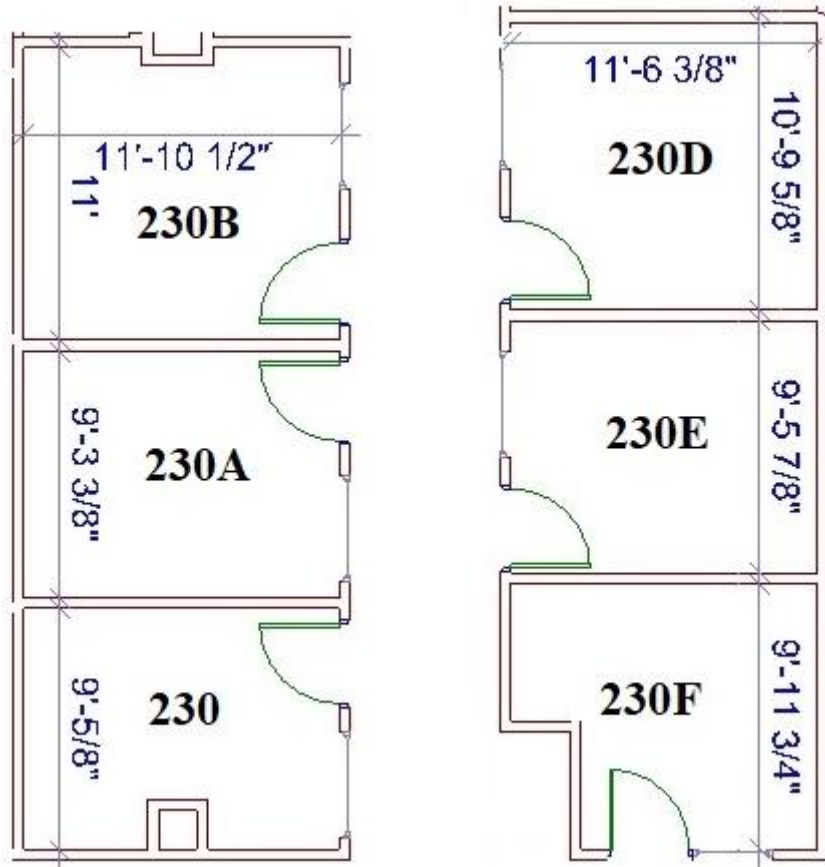

INFORMATION HEREIN IS SUBJECT TO VERIFICATION BY ALL PARTIES AND MAY CHANGE WITHOUT NOTICE. PLANS NOT TO SCALE; FOR GENERAL APPROXIMATION ONLY; SUBJECT TO CHANGE, REVISION, OMISSION AT ANY TIME.

## Suite 260

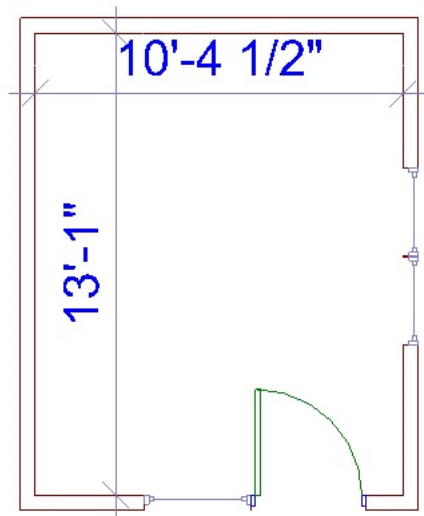

## Suite 260A

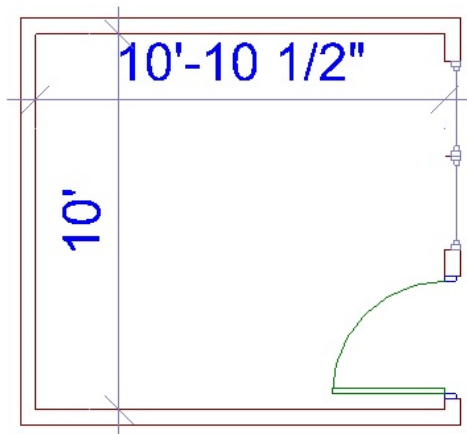

INFORMATION HEREIN IS SUBJECT TO VERIFICATION BY ALL PARTIES AND MAY CHANGE WITHOUT NOTICE. PLANS NOT TO SCALE; FOR GENERAL APPROXIMATION ONLY; SUBJECT TO CHANGE, REVISION, OMISSION AT ANY TIME.

# Suite 270

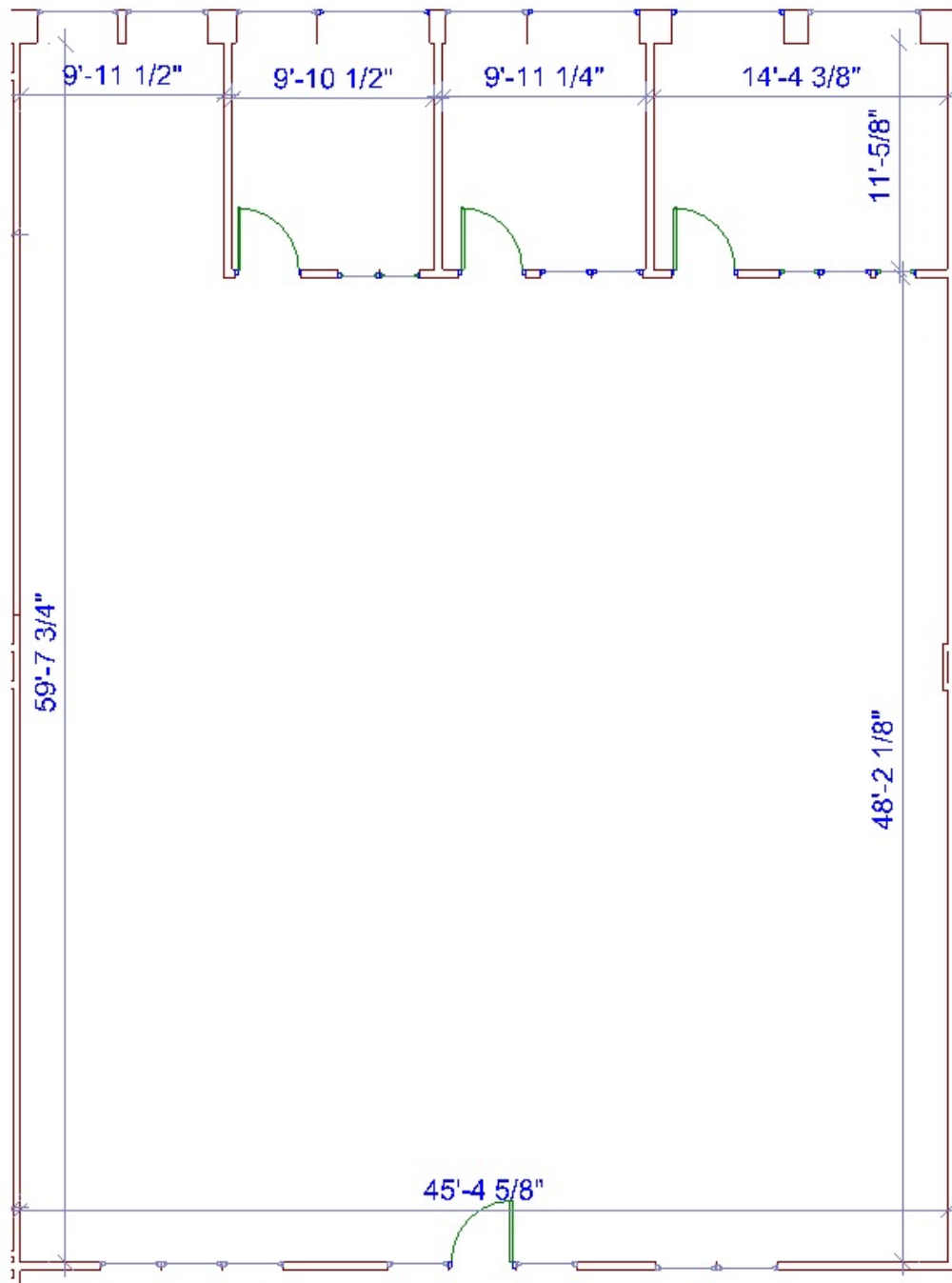

INFORMATION HEREIN IS SUBJECT TO VERIFICATION BY ALL PARTIES AND MAY CHANGE WITHOUT NOTICE. PLANS NOT TO SCALE; FOR GENERAL APPROXIMATION ONLY; SUBJECT TO CHANGE, REVISION, OMISSION AT ANY TIME.