



THE DENVER GROUP  
COMMERCIAL



# FOR LEASE

**MULTI-TENANT INDUSTRIAL/FLEX PROPERTY**  
**19336 Goddard ranch court, morrison | 115-998 sq ft available**

# PROPERTY DETAILS

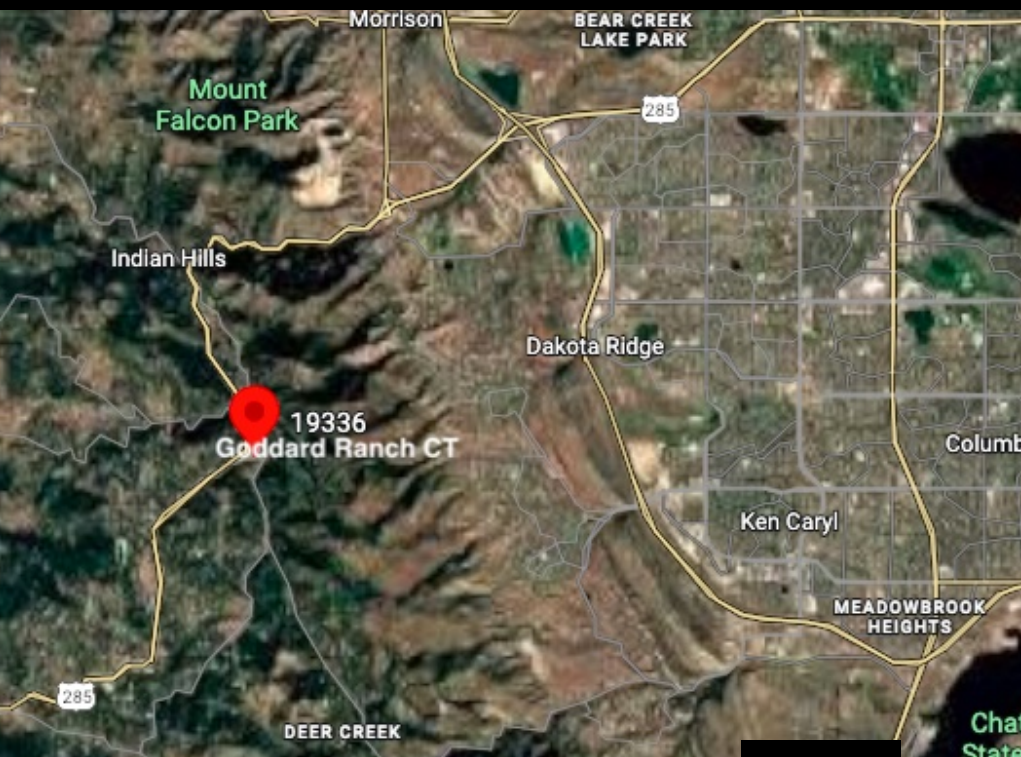

- 12,000 SF multi-tenant industrial/flex property
- 2-acre lot in a supply-constrained market
- Flexible layout – mix of office and small bay industrial units
- Option to add garage doors for additional warehouse space
- Strong tenant mix with solid income
- Value-add potential through rent increases & NNN conversion
- Seller financing available
- Ample parking per unit
- Prime location just off Hwy 285
- Common area restrooms maximize usable warehouse space



COMPASS

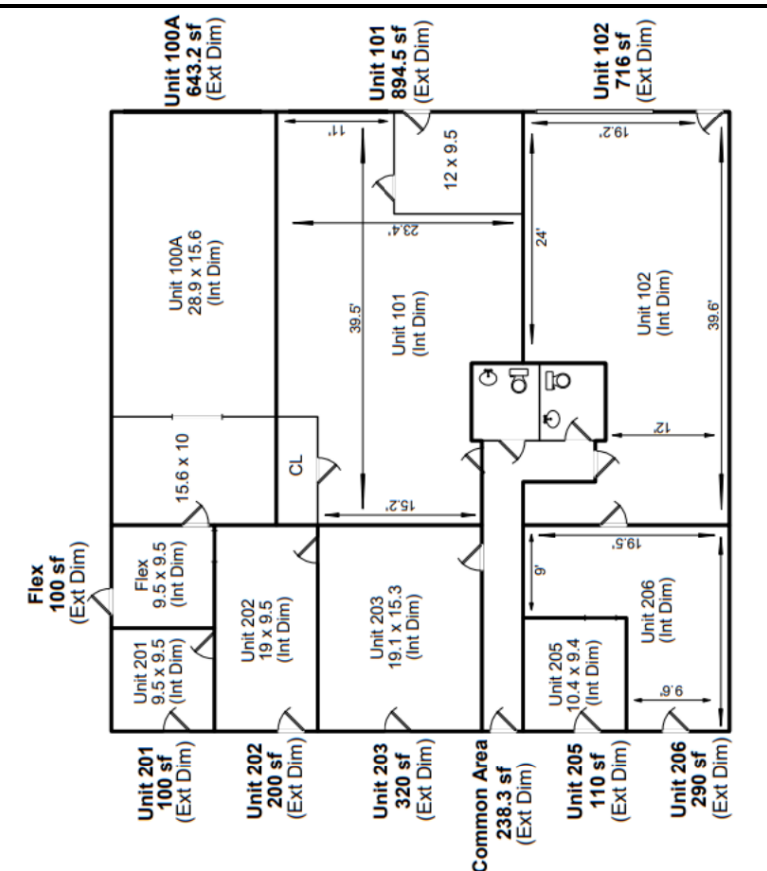
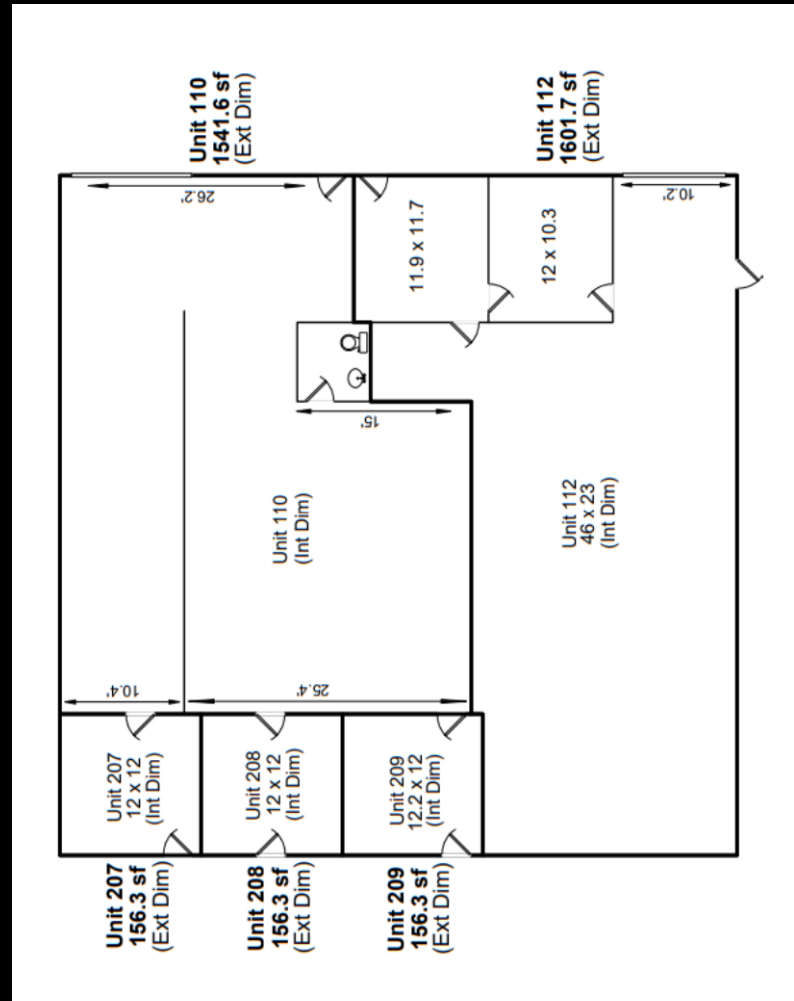
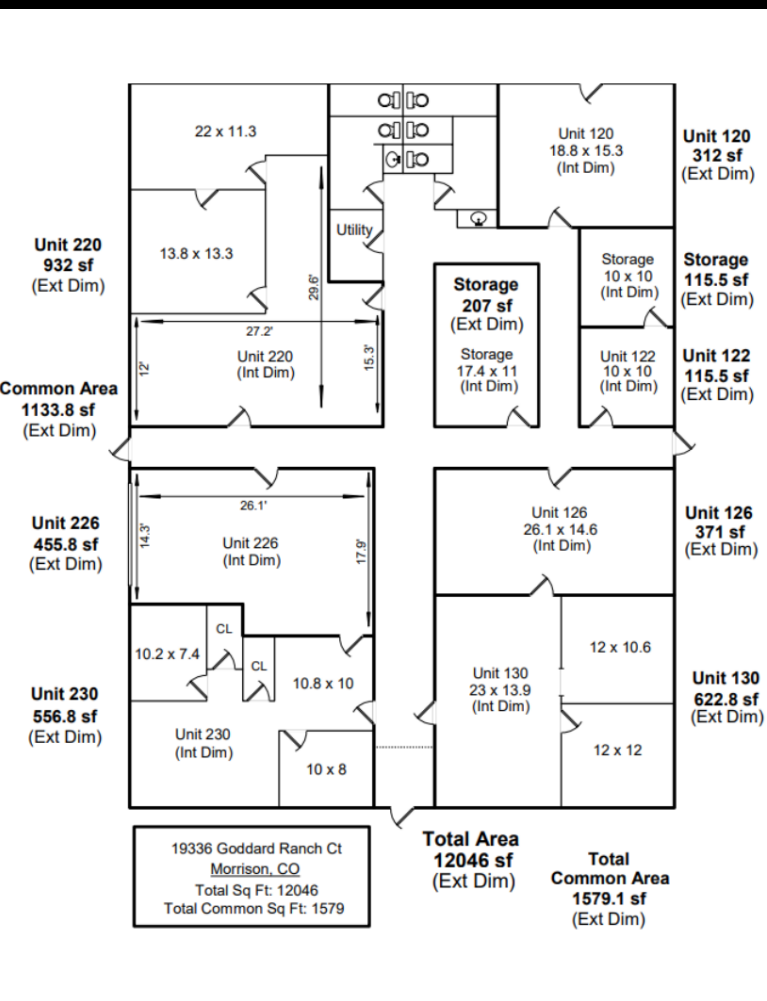



## David Williams

Senior Broker  
M: 720.312.6226  
[david.williams@compass.com](mailto:david.williams@compass.com)



**DG** THE DENVER GROUP

COMMERCIAL