

ORLANDOLOGISTICSPARK.COM



# Orlando Logistics Park at LeeVista

**+/- 71 ACRES LOCATED IN ORLANDO, FL**  
36,000 - 350,000 SF spaces available



AMBROSE

 JLL

BUILDING I: +/- 9.3 acres    BUILDING II: +/- 31 acres    BUILDING III: +/- 30.9 acres

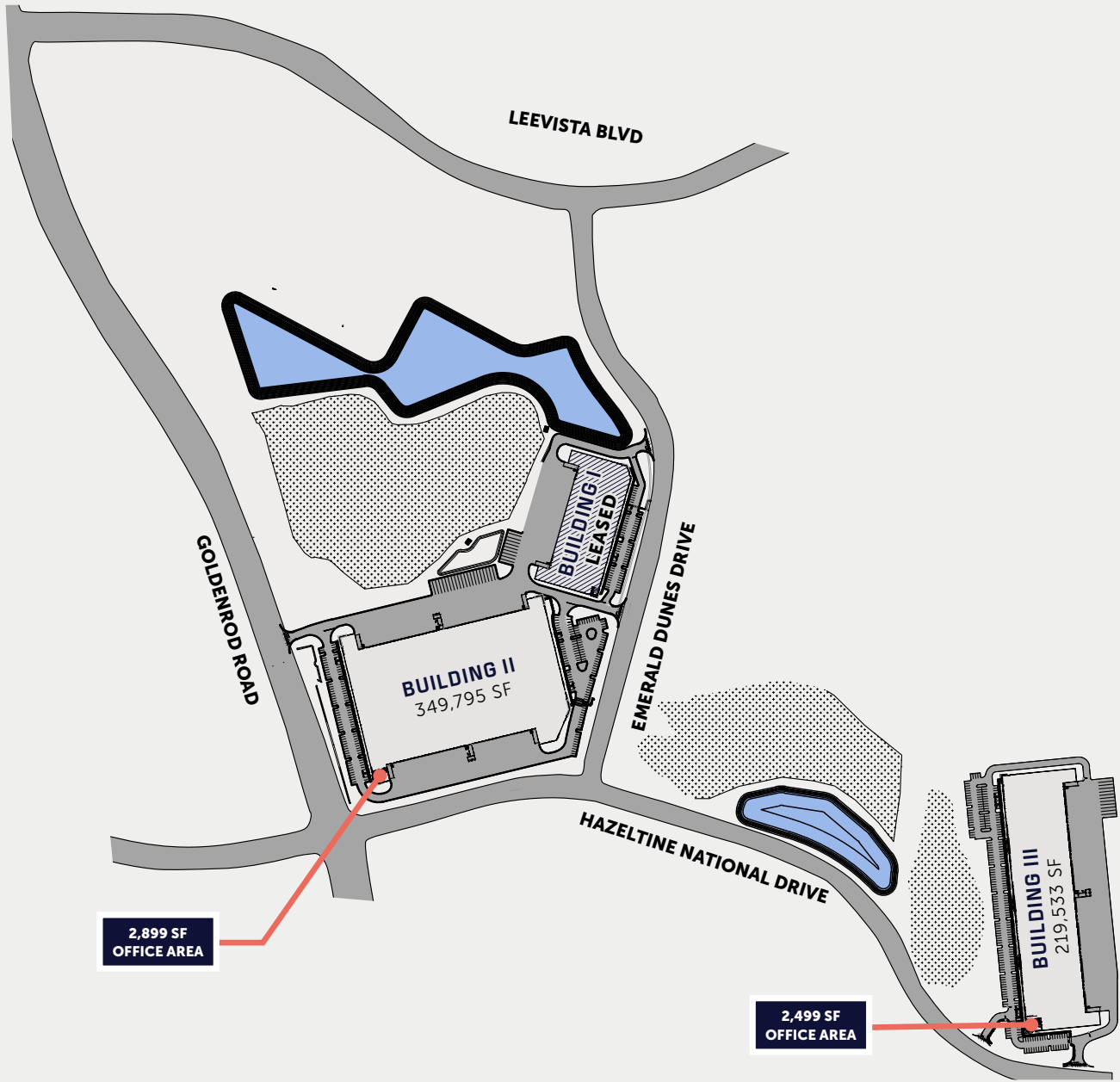

## Buildings II & III

**AVAILABLE NOW**  
for Immediate Fixturing

**WATER & ELECTRIC**  
Orlando Utilities Commission

**SEWER**  
City of Orlando

**DATA**  
AT&T

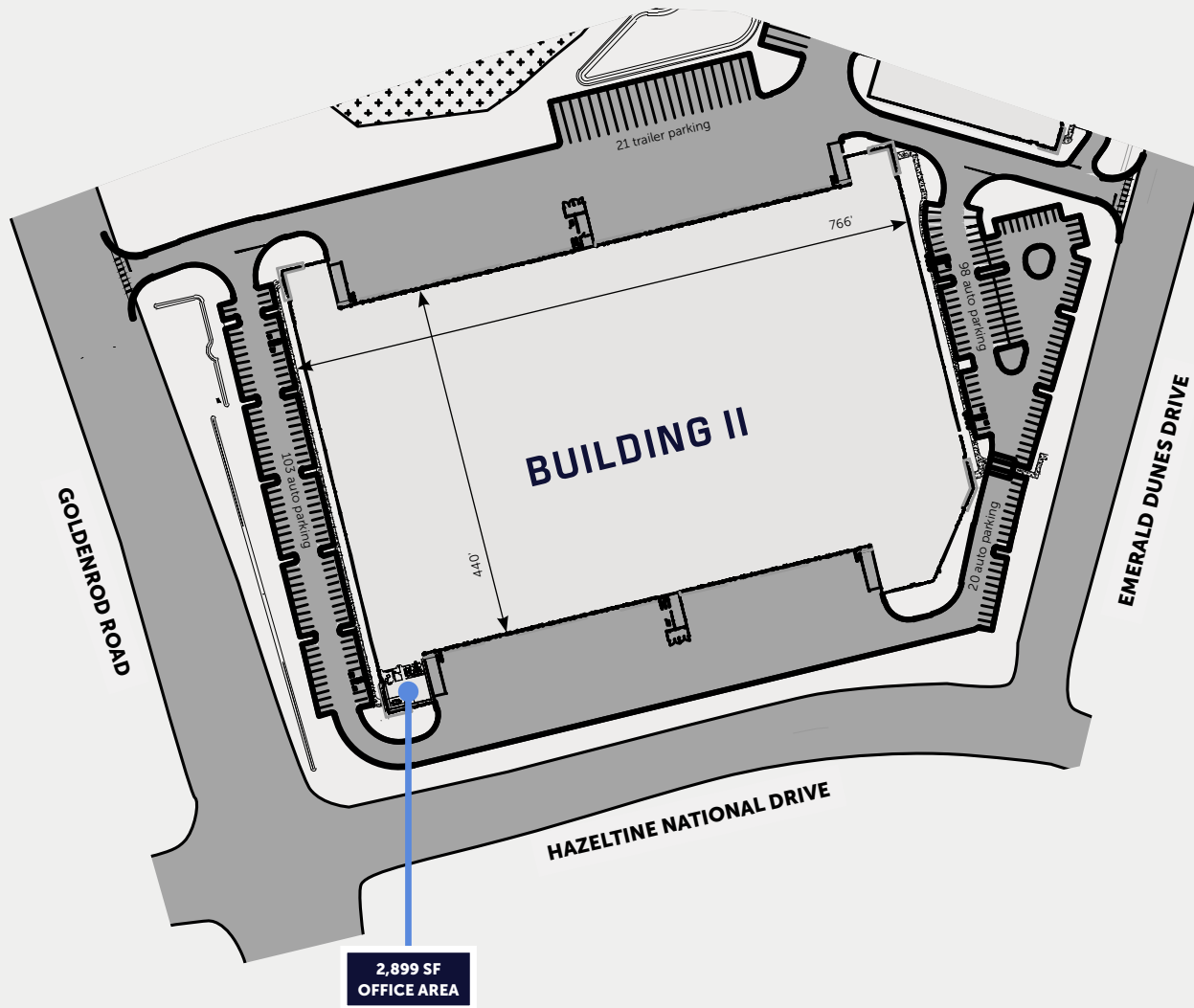

## 349,795 SF

175,000 SF min. divisibility

2,899 SF office area

221 auto parking

21 trailer parking

36' clear height

54' x 53'4" typical bays

54' x 60' speed bays

79 docks

4 drive-in doors (12' x 14')

7" thick unreinforced slab

Two 800-amp 480/277v three-phase power services (expandable)

### AVAILABLE NOW

for Immediate Fixturing

LEED® GOLD CERTIFIED



2,899 SF  
OFFICE AREA

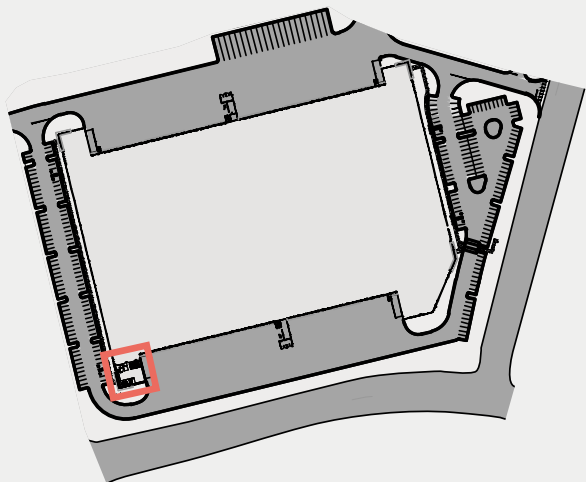

7485 HAZELTINE NATIONAL DR, ORLANDO, FL 32822

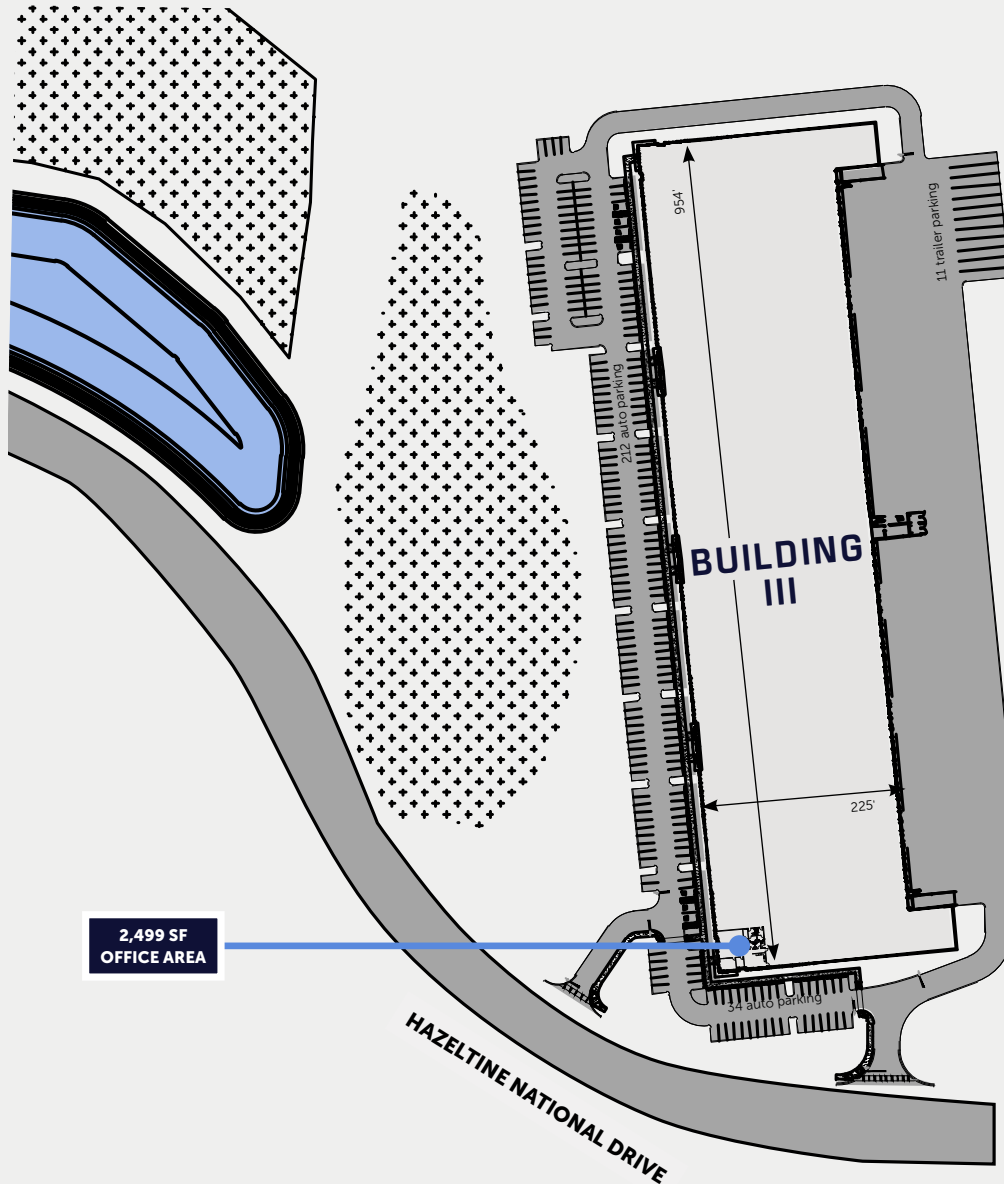

## 219,533 SF

36,000 SF min. divisibility

2,499 SF office area

246 auto parking

11 trailer parking

32' clear height

54' x 55' typical bays

54' x 60' speed bays

52 docks

2 drive-in doors (12' x 14')

7" thick unreinforced slab

Two 800-amp 480/277v three-phase power services (expandable)

### AVAILABLE NOW

for Immediate Fixturing

SEEKING LEED® SILVER CERTIFICATION

2,499 SF  
OFFICE AREA

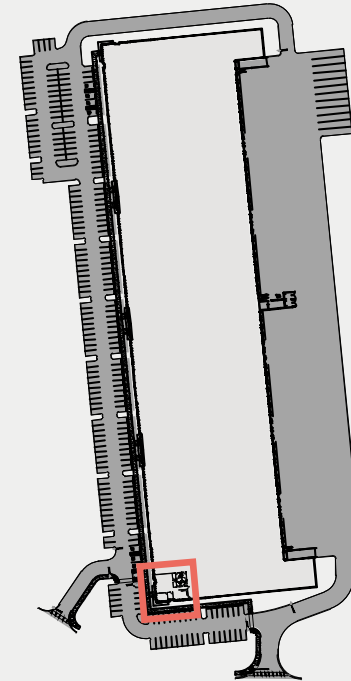
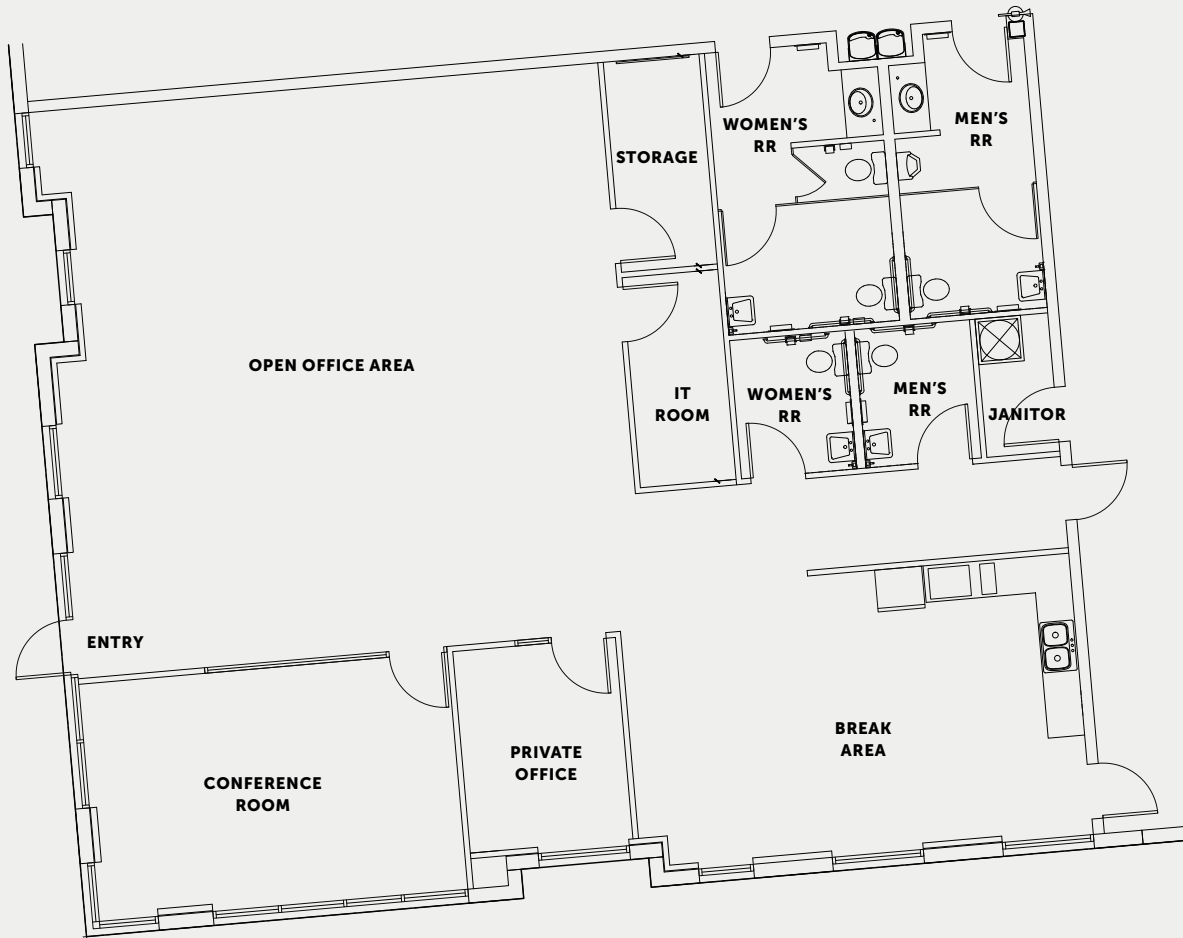

## A

## ACCESS, LABOR &amp; ADVANTAGES

Situated directly north of the Orlando International Airport, **Orlando Logistics Park at LeeVista is comprised of three buildings offering a variety of building sizes to meet user needs with easy highway access to SR 528 and Florida's Turnpike.**

- Located in Orlando, Florida, Airport/Southeast submarket.
- Buildings are 2-4 minutes to SR 528 and approx. 12 minutes to Florida's Turnpike, which provides unparalleled access to central and Southeast Florida.
- **5-minute drive time to Orlando International Airport (MCO)**, one of the busiest airports in the nation with several cargo lines, including DHL Aviation, FedEx and UPS.
- Orlando has a population of over three million people and one million employees within a one-hour drive
- **Florida consistently ranks among the best states for business** thanks to its pro-business state tax policies, competitive cost of doing business and streamlined regulatory environment.
- Florida ranks as the **2nd largest foreign trade zone network in the U.S.**

Orlando offers *notable access* to other key state and U.S. markets.

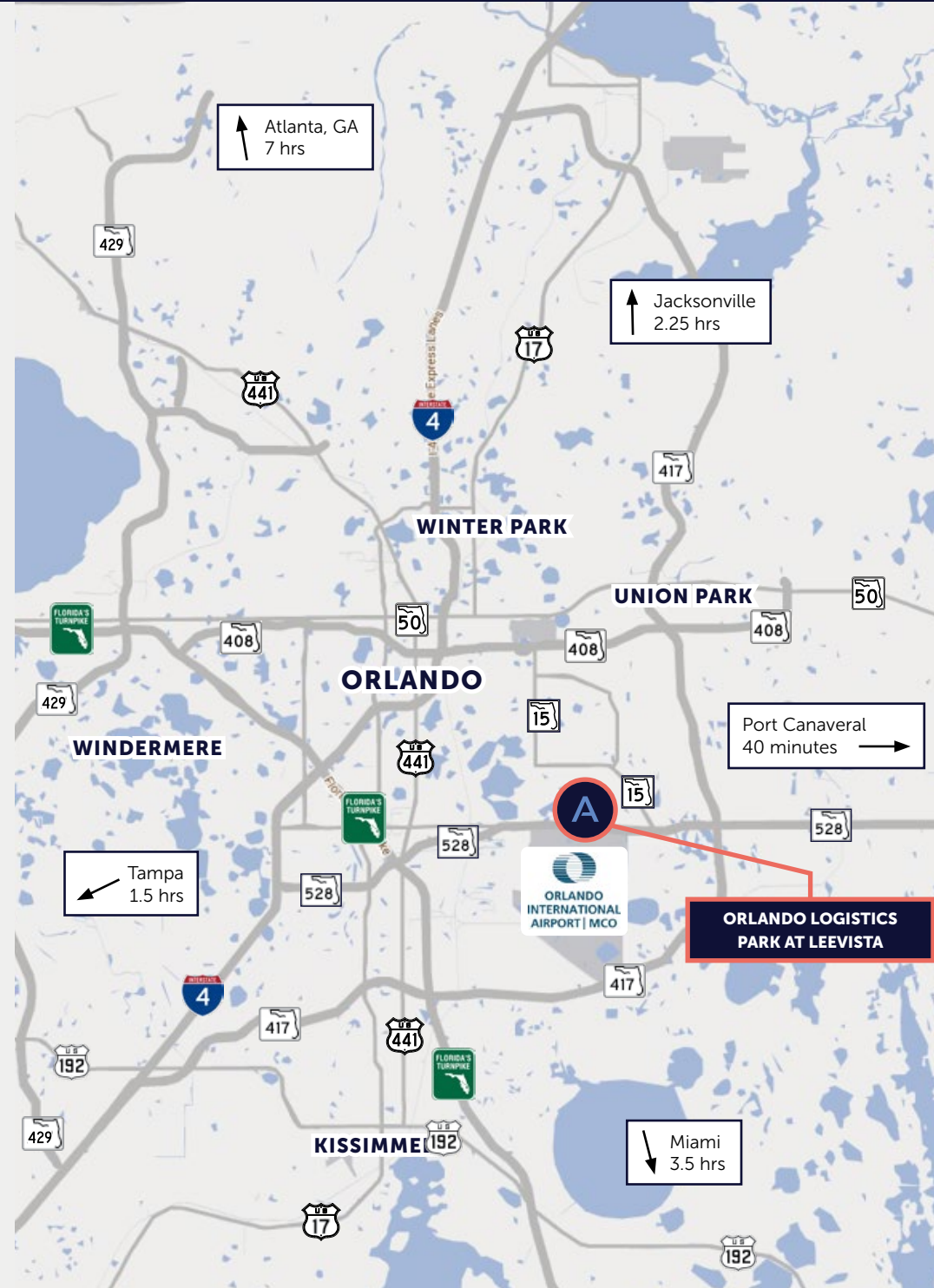

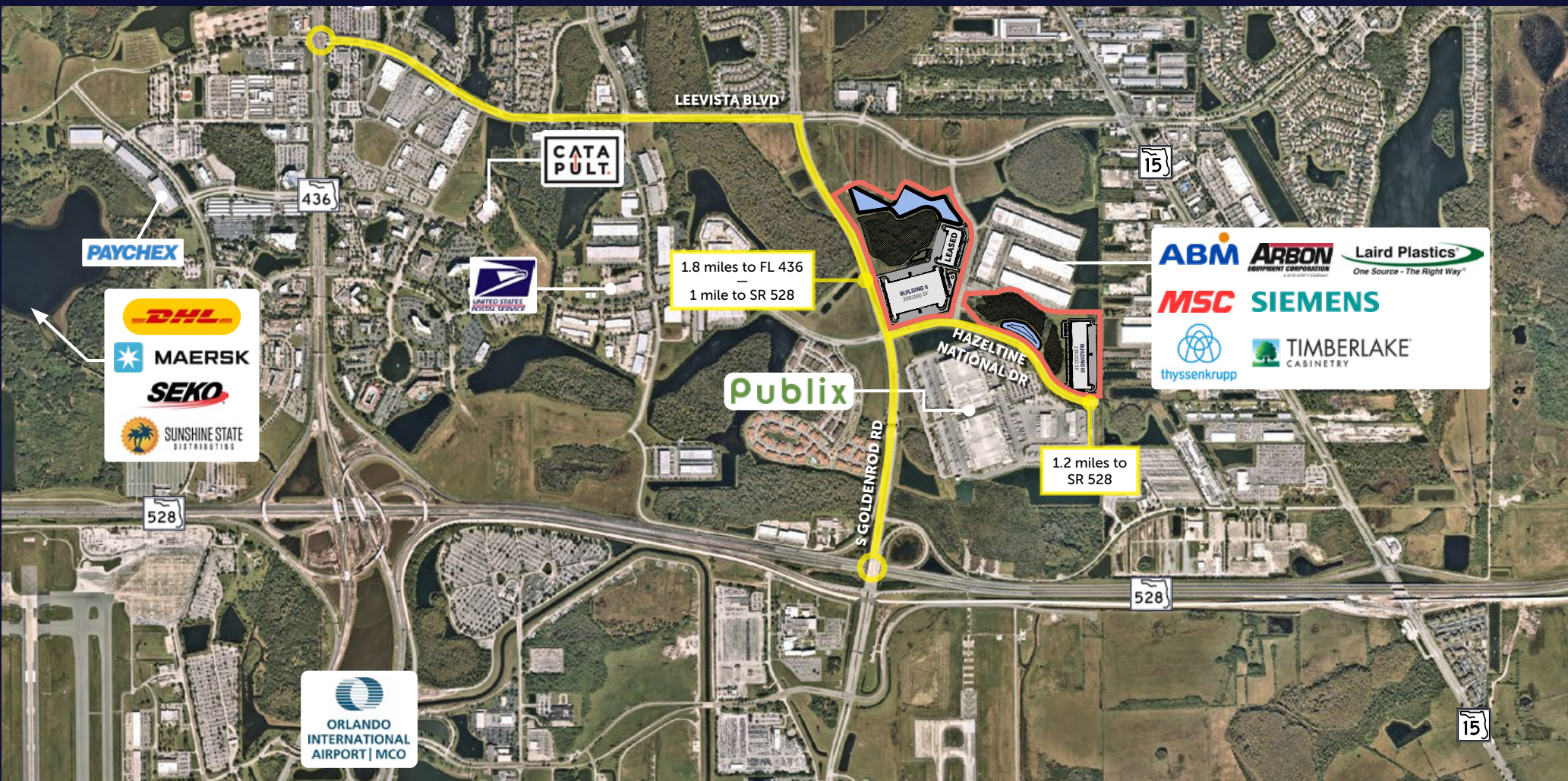

# Orlando Logistics Park at LeeVista

[ORLANDOLOGISTICSPARK.COM](http://ORLANDOLOGISTICSPARK.COM)  
[AMBROSEPG.COM/PROPERTIES](http://AMBROSEPG.COM/PROPERTIES)

**DAVE LOUDENSLAGER**  
 VP, Development & Florida Market Officer, Ambrose  
[dloudenslager@ambrosepg.com](mailto:dloudenslager@ambrosepg.com) | 954.826.2306

**MATTHEW E. SULLIVAN, SIOR, CCIM**  
 Executive Managing Director, JLL  
[Matt.Sullivan@jll.com](mailto:Matt.Sullivan@jll.com) | 407.930.1802

**BOBBY ISOLA, SIOR, CCIM**  
 Executive Managing Director, JLL  
[Bobby.Isola@jll.com](mailto:Bobby.Isola@jll.com) | 407.930.1804

**AMBROSE**

