

207 BOWERY

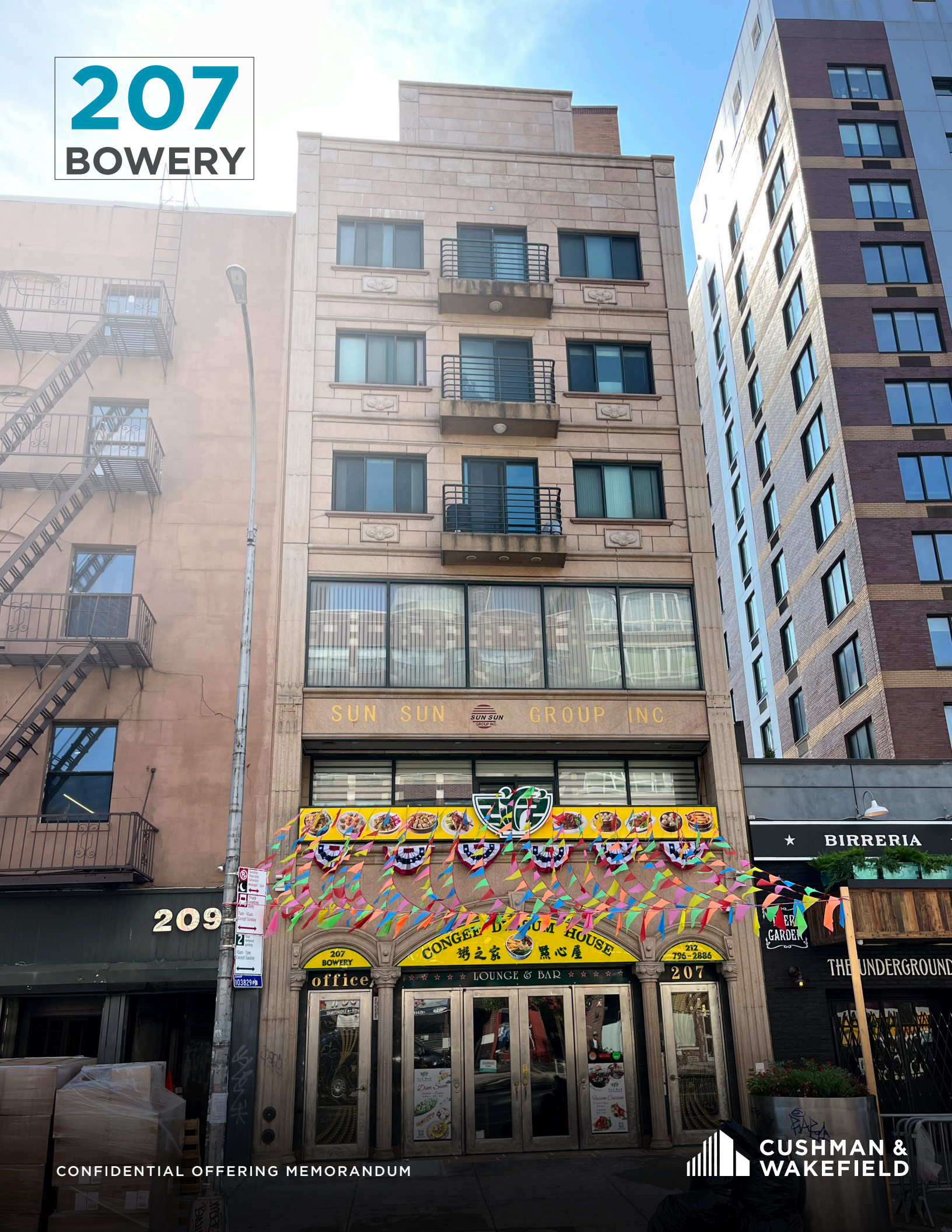

SUN SUN GROUP INC



209

207 BOWERY office

CONGEE & DIM SUM HOUSE
粥之家 點心屋

212 796-2886 207

BIRRERIA

THE UNDERGROUND

ASKING PRICE
\$19,500,000

TABLE OF CONTENTS

- 01 Executive Summary
- 03 Property Information
- 05 Financials
- 07 Floor Plans
- 13 Neighborhood Information

OFFERING MEMORANDUM DISCLAIMER

This Confidential Offering Memorandum ("Memorandum") is being delivered subject to the terms of the Confidentiality Agreement (the "Confidentiality Agreement") signed by you and constitutes part of the Confidential Information (as defined in the Confidentiality Agreement). It is being given to you for the sole purpose of evaluating the possible investment in 207 Bowery, New York, NY (the "Project"), and is not to be used for any other purpose or made available to any other party without the prior written consent of its exclusive broker, Cushman & Wakefield. This Memorandum was prepared by Cushman & Wakefield based primarily on information supplied by Managing Member. It contains select information about the Project and the real estate market but does not contain all the information necessary to evaluate the Project. The financial projections contained herein (or in any other Confidential Information) are for general reference only. They are based on assumptions relating to the overall economy and local competition, among other factors. Accordingly, actual results may vary materially from such projections. Various documents have been summarized herein to facilitate your review; these summaries are not intended to be a comprehensive statement of the terms or a legal analysis of such documents. While the information contained in this Memorandum and any other Confidential Information is believed to be reliable, neither Cushman & Wakefield nor Managing Member guarantees its accuracy or completeness. Because of the foregoing and since the investment in the Project is being offered on an "As Is, Where Is" basis, a prospective investor or other party authorized by the prospective investor to use such material solely to facilitate the prospective purchaser's investigation, must make its independent investigations, projections and conclusions regarding the investment in the Project without reliance on this Memorandum or any other Confidential Information. Although additional Confidential Information, which may include engineering, environmental or other reports, may be provided to qualified parties as the marketing period proceeds, prospective purchasers should seek advice from their own attorneys, accountants, engineers and environmental experts. Neither Cushman & Wakefield nor Managing Member guarantees the accuracy or completeness of the information contained in this Memorandum or any other Confidential Information provided by Cushman & Wakefield and Managing Member. Managing Member expressly reserves the right, at its sole discretion, to reject any offer to invest in the Project or to terminate any negotiations with any party at any time with or without written notice. Managing Member shall have no legal commitment or obligations to any prospective investor unless and until a written sale agreement has been fully executed, delivered and approved by Managing Member and any conditions to Managing Member's obligations thereunder have been satisfied or waived. Managing Member has retained Cushman & Wakefield as its exclusive broker and will be responsible for any commission due to Cushman & Wakefield in connection with a transaction relating to the Project pursuant to a separate agreement. Cushman & Wakefield is not authorized to make any representation or agreement on behalf of Managing Member. Each prospective investor will be responsible for any claims for commissions by any other broker in connection with an investment in the Project if such claims arise from acts of such prospective investor or its broker. This Memorandum is the property of Managing Member and all parties approved by Managing Member and may be used only by parties approved by Managing Member. No portion of this Memorandum may be copied or otherwise reproduced or disclosed to anyone except as permitted under the Confidentiality Agreement.

For more information, please contact Exclusive Agents:

BRYAN F. HURLEY
Senior Director
212 660 7706
bryan.hurley@cushwake.com

MICHAEL F. DECHESER
Senior Managing Director
212 660 7772
michael.decheser@cushwake.com

RICKY LIANG
Wholesome Realty Management Inc.
917 288 5244
rliang@sunsungroup.com

EXECUTIVE SUMMARY

Cushman & Wakefield is pleased to announce it has been retained on an exclusive basis to arrange the sale of 207 Bowery. This ~20,658 square foot mixed-use elevator building is located on the east side of Bowery between Delancey and Rivington Streets in the Lower East Side neighborhood of Manhattan.

The building consists of a fully built out restaurant on the ground floor and lower level and six floor through apartments on floors 2-7. The restaurant has a kitchen, office, 4 bathrooms, three main dining areas and two private dining rooms. There are 13.5' ceiling heights on the lower level of the restaurant with an ADA compliant elevator.

The 2nd floor apartment will have 5 bedrooms and 3 bathrooms. The 3rd floor apartment will have has The 4th floor apartment has 4 bedrooms and 2 bathrooms with ~496 SF of outdoor space. The 5th floor has 4 bedrooms and 2 bathrooms with ~496 SF of outdoor space. The 6th floor apartment has 4 bedrooms and 2 bathrooms with ~76 SF of outdoor space. The 7th floor has 14' ceiling heights in the living room, 5 bedrooms, 3 bathrooms and ~460 SF of outdoor space.

The original building was a 4-story commercial building that was gutted and extended an additional 3 stories in 2004. The foundation was dug out during the enlargement of the building to maximize the usable space in the retail. All units in the building have central air conditioning, washer/dryers, direct elevator access to the units, outdoor space, and good ceiling heights.

The property is centrally located at the intersection of the LES and Nolita. Neighbors include the Bowery Supreme store, CitizenM Hotel, Unititled, Freemans Alley, The Moxy, Sohotel, Vince, Marine Layer, Everlane, Prince Street Pizza, Tacombi, Black See Bagels, The Butcher's Daughter, Ray's, along with many more restaurants and shops. It is half a block from the Bowery J/Z Station, four blocks to the Spring St 6 Station, four blocks to the Grand Street B/D Station and five blocks to the 2nd Avenue F Station.



01 / 207 BOWERY

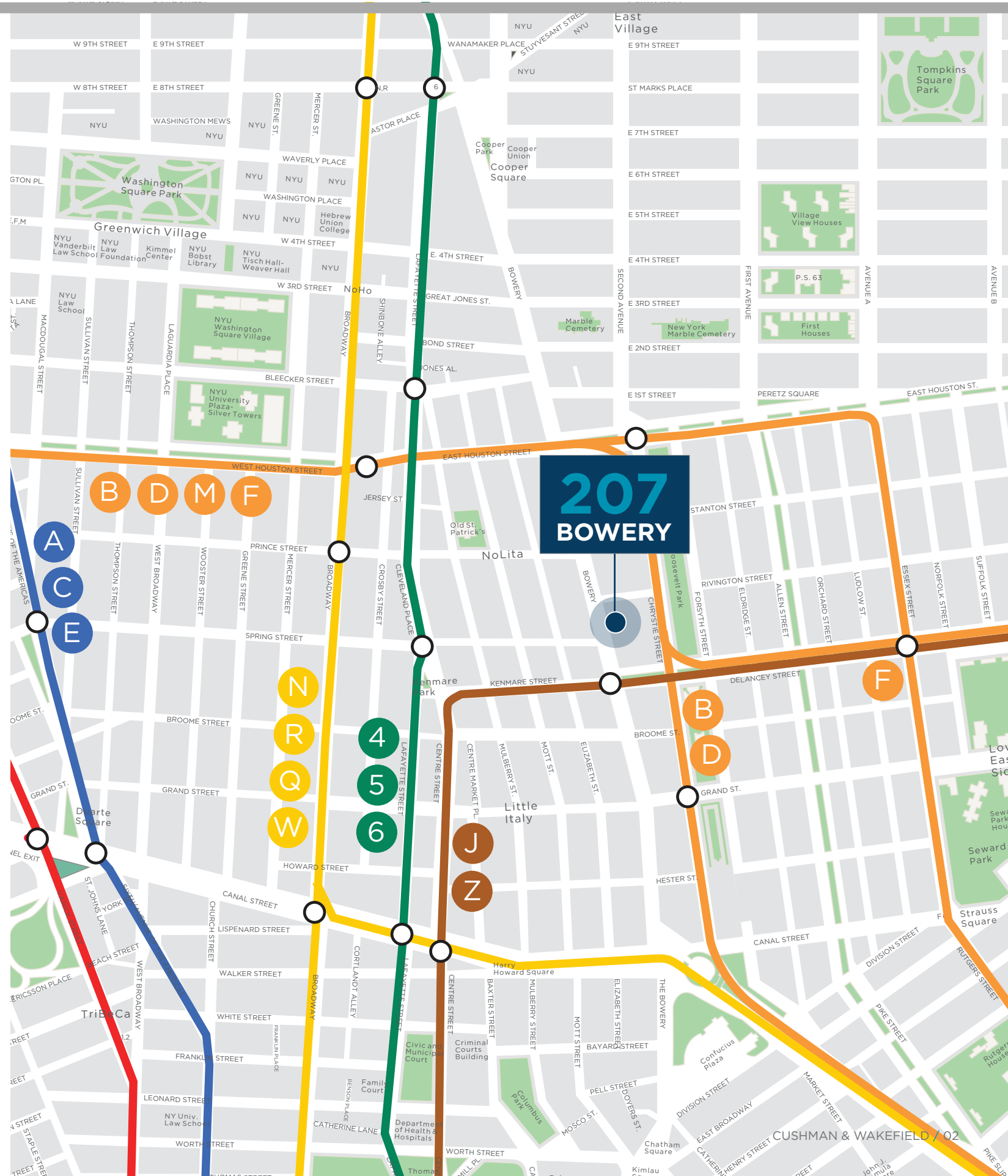

PROPERTY INFORMATION

PROPERTY INFORMATION

207
BOWERY



ASKING PRICE:
\$19,500,000

FINANCIAL SUMMARY

Gross Annual Revenue	\$1,304,604
Expenses & Vacancy Loss	\$342,484
Net Operating Income	\$962,120

Price Per Square Foot:	\$944
In Place Cap Rate:	4.93%
Gross Rent Multiple:	14.94

PROPERTY INFORMATION

Address:	207 Bowery
Location:	New York, NY
Block & Lot:	425 - 13
Lot Dimensions:	27.5' x 100.5' (approx.)
Lot SF:	2,684 SF (approx.)

BUILDING INFORMATION

Property Type:	Mixed-Use Elevator	
Building Dimensions:	27.5' x 100.5' (approx.)	
Stories:	7	
Year Built:	1915	
Lower Level SF:	2,683	27.5' x 100.5' (approx.)
1st Floor SF:	2,683	27.5' x 100.5' (approx.)
Mezzanine SF:	903	27.5' x 32' (approx.)
2nd Floor SF:	2,683	27.5' x 100.5' (approx.)
3rd Floor SF:	2,683	27.5' x 100.5' (approx.)
4th Floor SF:	2,683	27.5' x 100.5' (approx.)
5th Floor SF:	2,251	27.5' x 66' (approx.)
6th Floor SF:	1,889	27.5' x 66' (approx.)
7th Floor SF:	1,824	27.5' x 66' (approx.)
7th Floor Mezzanine SF:	376	27.5' x 15.5' (approx.)
Usabel Gross SF:	20,658 SF (approx.)	
Residential Units:	6 (currently converting 2nd and 3rd floor to residential)	
Commercial Units:	1	
Total Units:	7	

NYC FINANCIAL INFORMATION (25/26)

Assessed Value:	\$1,836,080
Annual Property Tax:	\$199,178
Tax Rate:	10.8480%
Tax Class:	4 (change to tax class 2B after conversion of office floors)

RESIDENTIAL REVENUE

Unit	Beds	Baths	Status	Lease Expiration	NSF	Monthly Rent
2	5	3	FM	05/31/27	2,489	\$14,000
3	5	3	FM	05/31/27	2,489	\$15,000
4	5	2	FM	06/30/26	2,489	\$13,500
5	4	2	FM	08/31/26	1,613	\$9,395
6	4	2	FM	08/31/26	1,613	\$11,495
7	5	3	FM	06/30/27	1,319	\$13,500
Monthly	28	15				\$76,890
Annual						\$922,680

COMMERCIAL REVENUE

Unit	Tenant	NSF	Lease Expiration	Monthly Rent
Commercial	Sip Champagne LLC	5,255	09/30/33	\$31,827
Annual Total				\$381,924

UNIT MIX

Beds	#	Unit %	Total Revenue	Revenue %	\$ / Unit
4	2	33%	\$250,680	27%	\$10,445
5	4	67%	\$672,000	73%	\$14,000
Total	6	100%	\$922,680	100%	\$12,815

Residential Revenue	SF	\$ / Unit	\$ / SF	Annual Income
Gross Annual Residential Income	12,012	\$153,780	\$76.81	\$922,680
Less General Vacancy / Credit Loss (3.0%)		\$3,845	\$1.92	\$23,067
Effective Gross Annual Income		\$149,936	\$74.89	\$899,613

Commercial Revenue	SF	\$ / Unit	\$ / SF	Annual Income
Gross Annual Commercial Income	5,255	\$381,924	\$72.68	\$381,924
Less General Vacancy / Credit Loss (7.0%)		\$19,096	\$3.63	\$19,096
Effective Gross Annual Income		\$362,828	\$69.04	\$362,828

Total Revenue	Annual Income
Gross Annual Commercial Income	\$1,304,604
Less General Vacancy / Credit Loss	\$42,163
Effective Gross Annual Income	\$1,262,441

Projected Operating Expenses		% of EGI	\$ / Unit	\$ / SF	Projected
Property Taxes	Actual	15.8%	\$28,454	\$11.08	\$199,178
Water and Sewer	Owner Provided	0.1%	\$210	\$0.08	\$1,468
Insurance	Owner Provided	1.5%	\$2,666	\$1.04	\$18,661
Fuel	Tenants Pay	0.0%	\$0	\$0.00	\$-
Electric	Owner Provided	0.3%	\$520	\$0.20	\$3,641
Elevator Maintenance	\$6,500/ Elevator	0.5%	\$929	\$0.36	\$6,500
Repairs & Maintenance	\$1,500/ Resi. Unit	0.7%	\$1,286	\$0.50	\$9,000
General & Administrative	\$1,000/ Resi. Unit	0.5%	\$857	\$0.33	\$6,000
Super / Payroll	\$1,500/ Month	1.4%	\$2,571	\$1.00	\$18,000
Management Fee	3.0% / EGI	3.0%	\$5,410	\$2.11	\$37,873
Total Expenses		23.8%	\$42,903	\$16.71	\$300,321

Net Operating Income	\$962,120
-----------------------------	------------------

4TH & 5TH FLOOR PLANS

6TH & 7TH FLOOR PLANS

4TH FLOOR

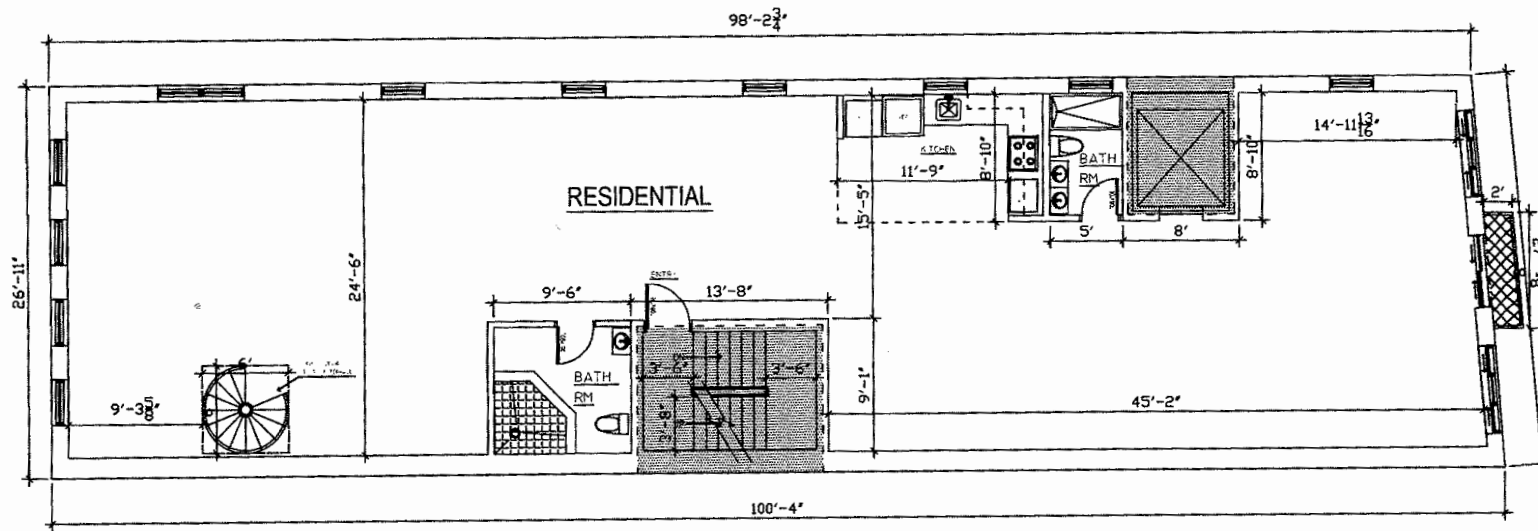

6TH FLOOR

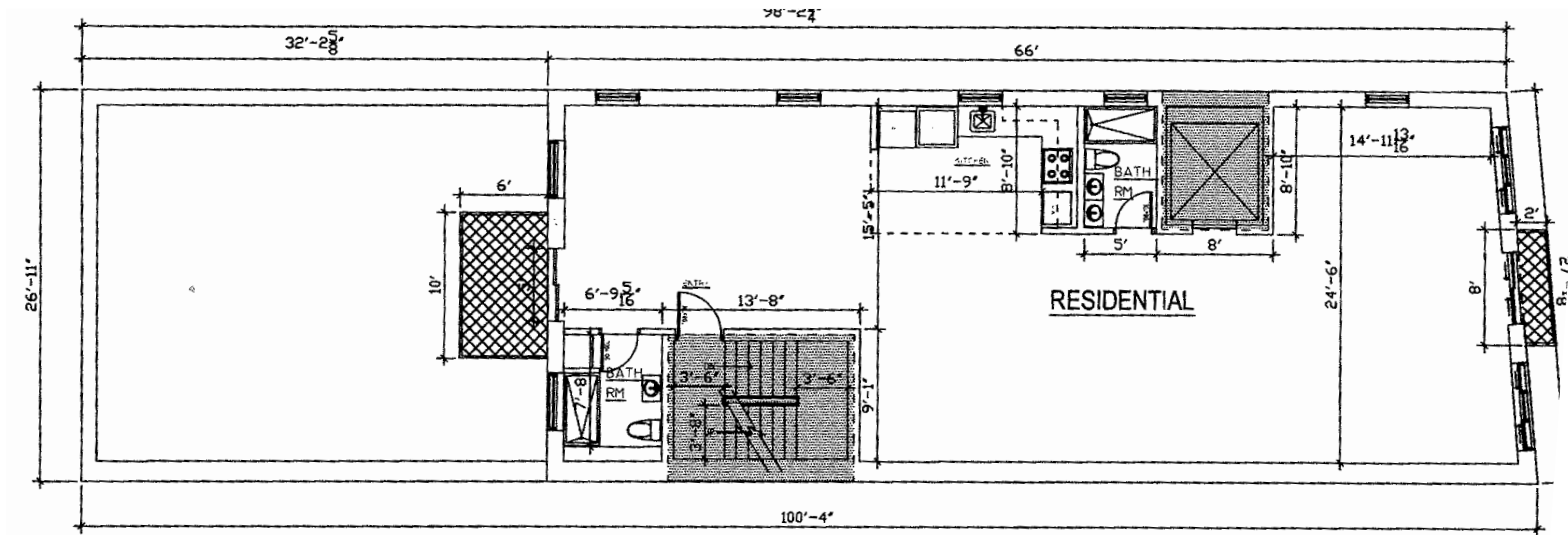

5TH FLOOR

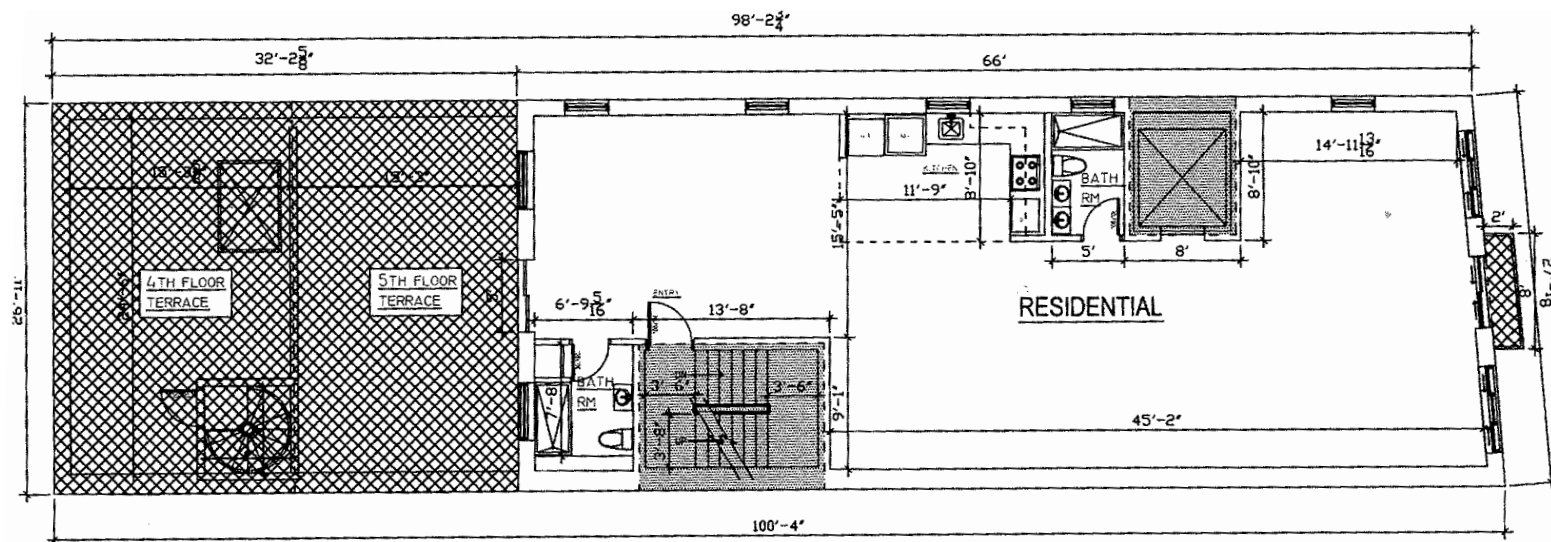

7TH FLOOR

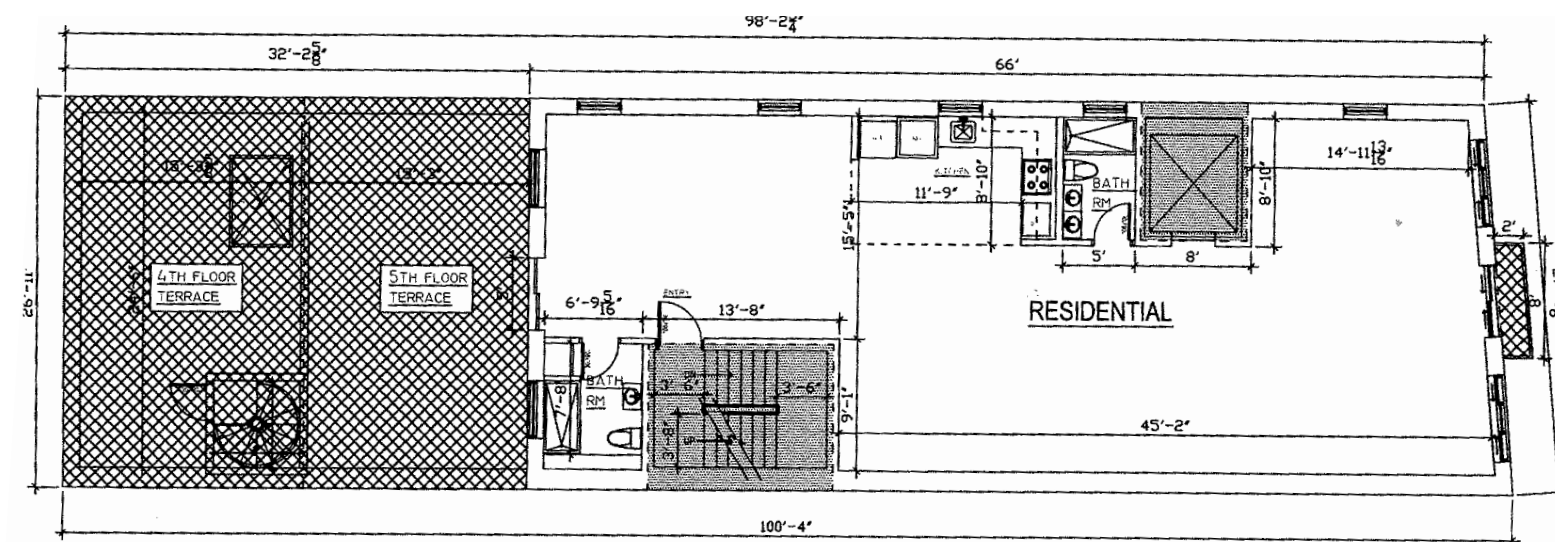

GROUND FLOOR

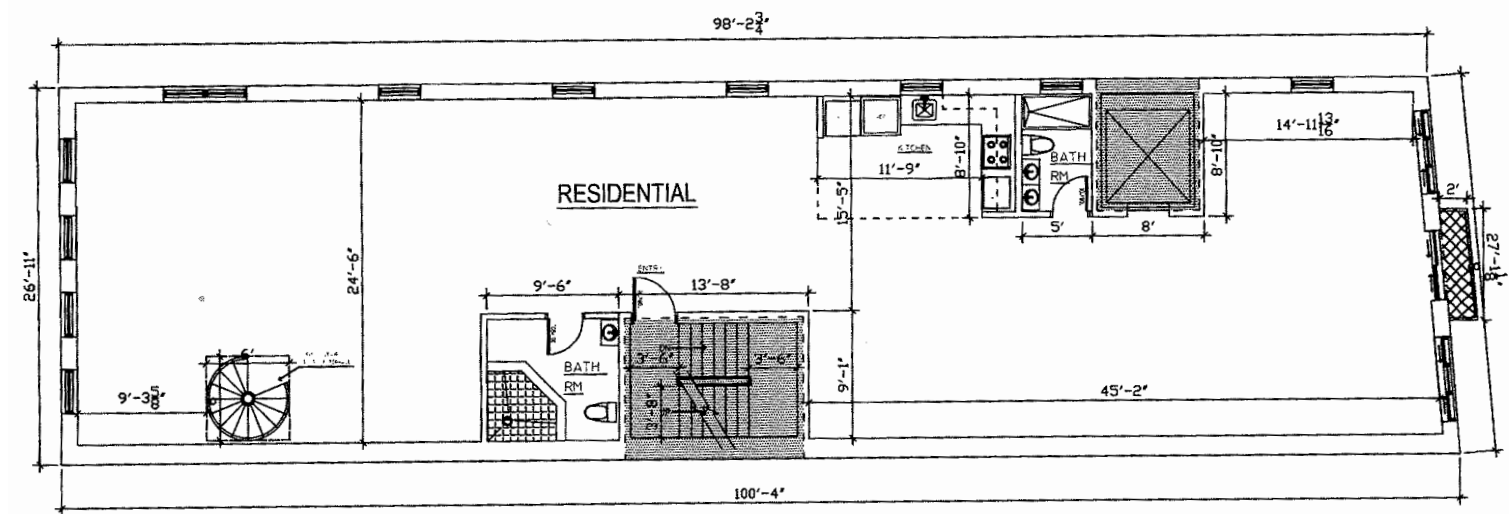
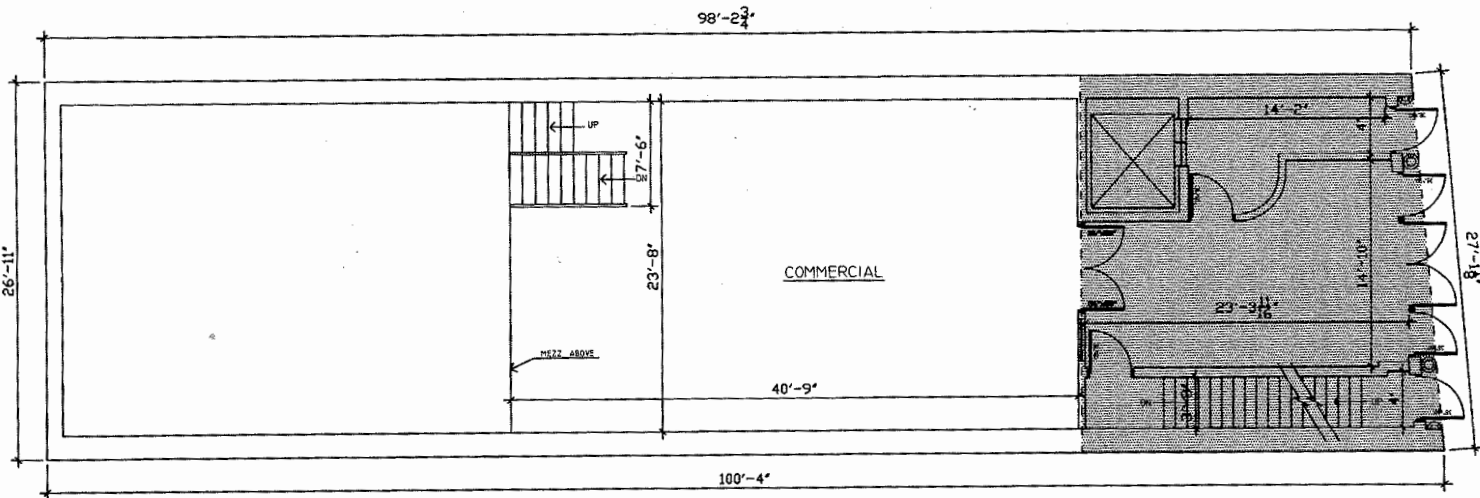

MEZZANINE

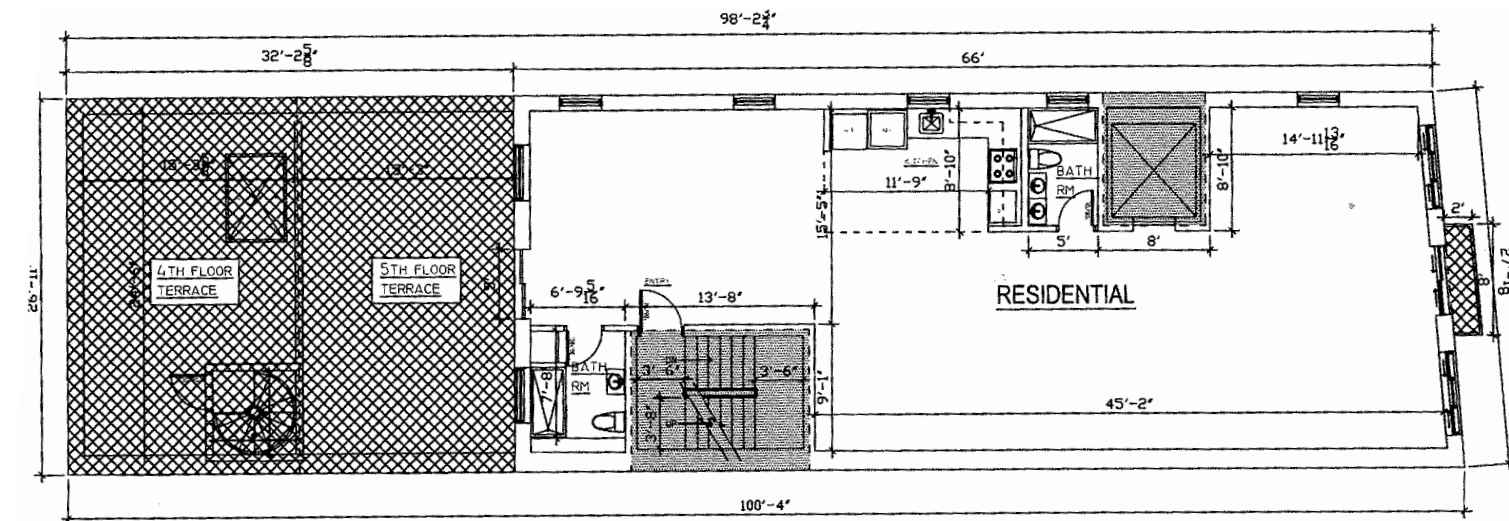
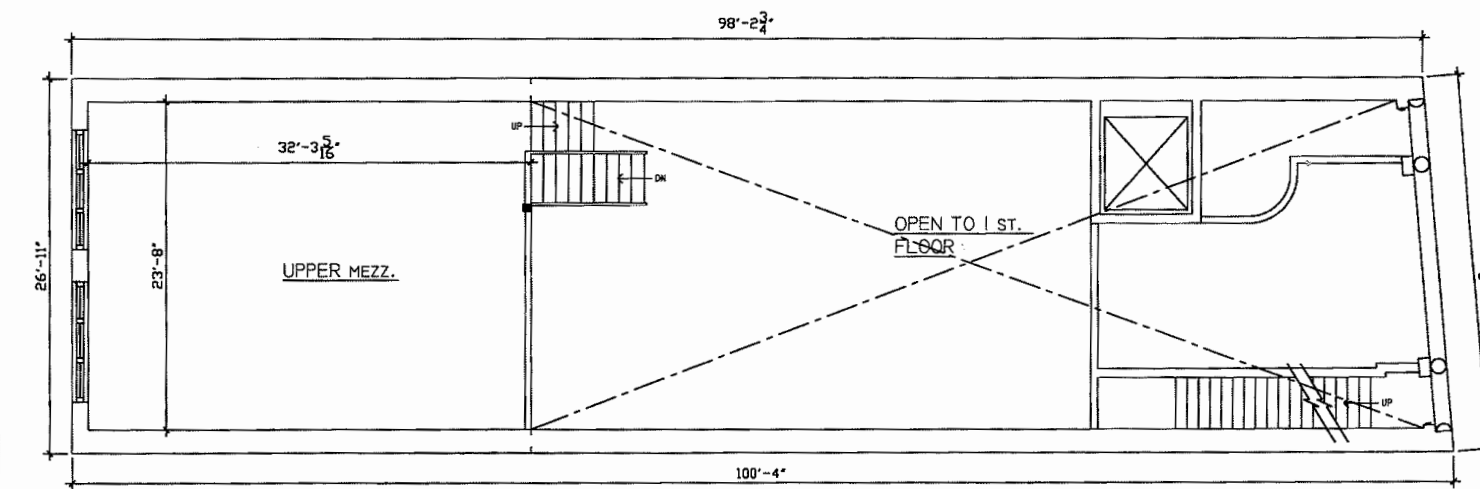

CELLAR

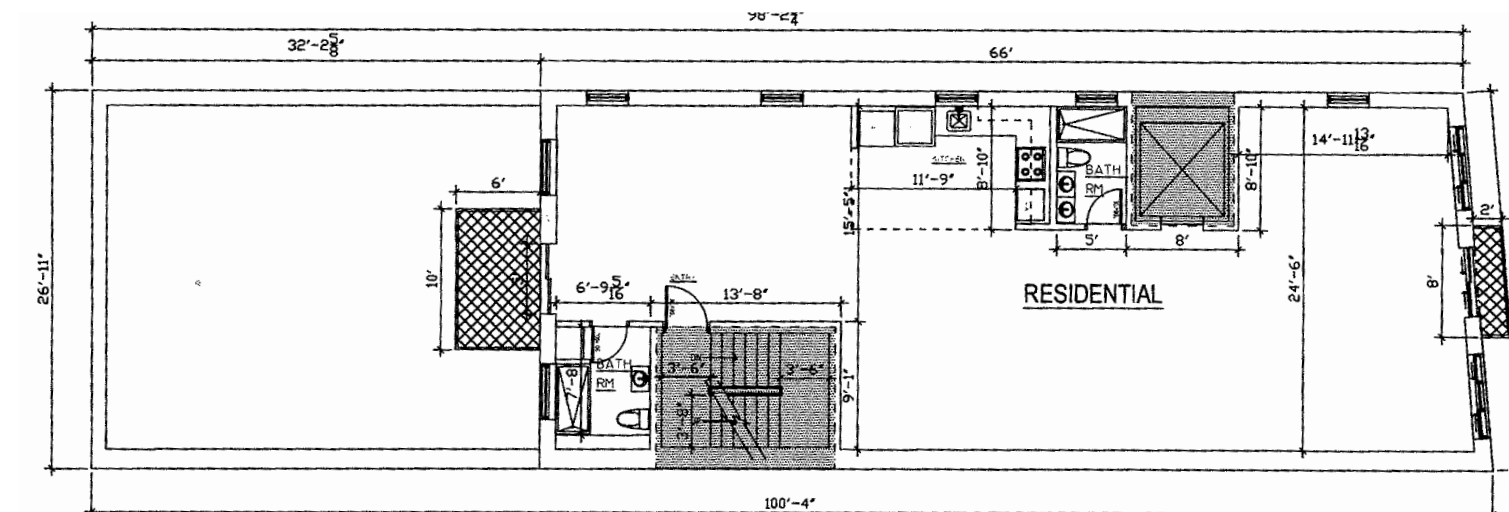
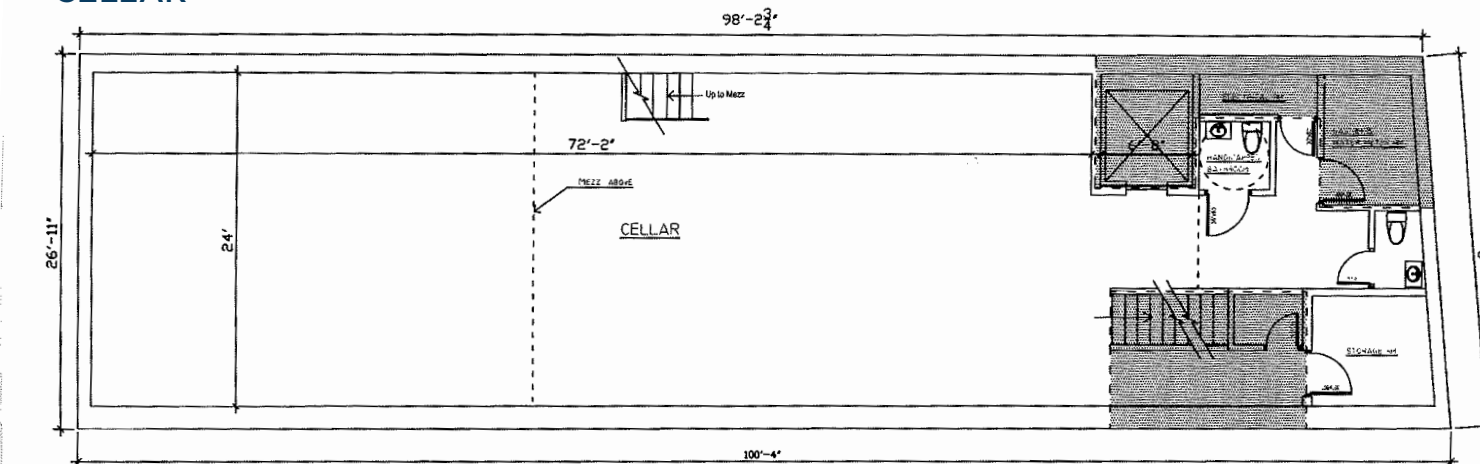

The Bowery is the name of both a street and a small neighborhood in the southern portion of the New York City borough of Manhattan. The neighborhood runs from East 4th Street just south of Astor Place, down to Canal Street where sits the heart of Chinatown.

The Bowery is the oldest thoroughfare on Manhattan Island, originally existing as a Lenape footpath, which spanned roughly the entire length of the island, from north to south. When the Dutch settled Manhattan island, they named the path Bouwerij road—bouwerij being an old Dutch word for farm because it connected farmlands and estates on the outskirts to the heart of the city in today's Wall Street/Battery Park area. The Bowery rivaled Broadway as a thoroughfare; as late as 1869, when it had gained the "reputation of cheap trade, without being disreputable" it was still "the second principal street of the city".

In the early to mid 1800's The Bowery was home to robust theaters, funded by wealthy families like the Astor's, for populist entertainments of equestrian shows and circuses. From its stylish beginning, the tone of the Bowery Theatre's offerings matched the slide in the social scale of the Bowery itself.



By the time of the Civil War, the mansions and shops had given way to low-brow concert halls, brothels, German beer gardens, pawn shops, and flophouses. The Bowery had become the turf of one of America's earliest street gangs, the Bowery Boys.

In the spirit of social reform, the first YMCA opened on the Bowery in 1873; another notable religious and social welfare institution established during this period was Bowery Mission, which was founded in 1880 at 36 Bowery. The mission has relocated along the Bowery throughout its lifetime. From 1909 to the present, the mission has remained at 227-229 Bowery.

Throughout the 20th century, the Bowery unfortunately became notable for its economic depression, lined with cheap clothing stores, prostitution and unorthodox activity. However, since the 1990s the entire Lower East Side has been reviving. Gentrification is contributing to ongoing change along the Bowery. In particular, the number of high-rise condominiums is growing. In 2006, AvalonBay Communities opened its first luxury apartment complex on the Bowery, which included an upscale Whole Foods Market. Avalon Bowery Place was quickly followed with the development of Avalon Bowery Place II in 2007. That same year, the SANAA-designed facility for the New Museum of Contemporary Art opened at the corner of Prince Street.

One neighborhood icon is the old Germania Bank building, 190 Bowery at Spring Street, which has become a mecca for street artists; its exterior is faded, rusted, corroded glory, with Beaux-Arts hints of another age splattered with the artistic statements of a new one. Famed NYC photographer Jay Maisel and his family have been the sole occupants since 1966.

Unlike other neighborhoods and districts of Manhattan, which were typically developed within a short period of time, the Bowery developed over four centuries of Euro-American history, and its extant architectural heritage is a diverse catalogue of architectural styles dating to every decade between 1780 and present. Throughout the length of the Bowery, there is no correlation between geography and age of building: the Bowery is uniformly irregular and therefore unique. The variety in age, style, scale, function, and texture contribute to the Bowery being one of New York's most architecturally diverse and historically significant streetscape.



For more information, please contact Exclusive Agents:

BRYAN F. HURLEY
Senior Director
212 660 7706
bryan.hurley@cushwake.com

MICHAEL F. DECHESER
Senior Managing Director
212 660 7772
michael.decheser@cushwake.com

RICKY LIANG
Wholesome Realty Management Inc.
917 285 244
ricky.liang@cushwake.com



209

103829#

207 BOWERY

CONGEE & DUMPLING HOUSE
粥之家 點心屋

212 795-2886

office

***** LOUNGE & BAR *****

207

