



# CLASS A OFFICE SPACE 4120 RIO BRAVO DRIVE EL PASO-WEST/CENTRAL



## PROPERTY HIGHLIGHTS

- One Story Executive Suites Office Building
- Minutes from Downtown El Paso
- All Inclusive Utilities
- HUB Zone Certified for Tenants with Government Clients
- Free, Ample Building Adjacent Parking
- Janitorial: General Cleaning and Trash Service Available 5 Nights per Week
- Temperature Controls in Suites
- Lounge with Snack and Soda Machines
- Conference Room Available to All Tenants

## ON-SITE PROPERTY MANAGEMENT & MAINTENANCE

- Full staff of qualified professional personnel to maintain the interior and exterior areas of the building
- 24 hour answering service available for emergencies

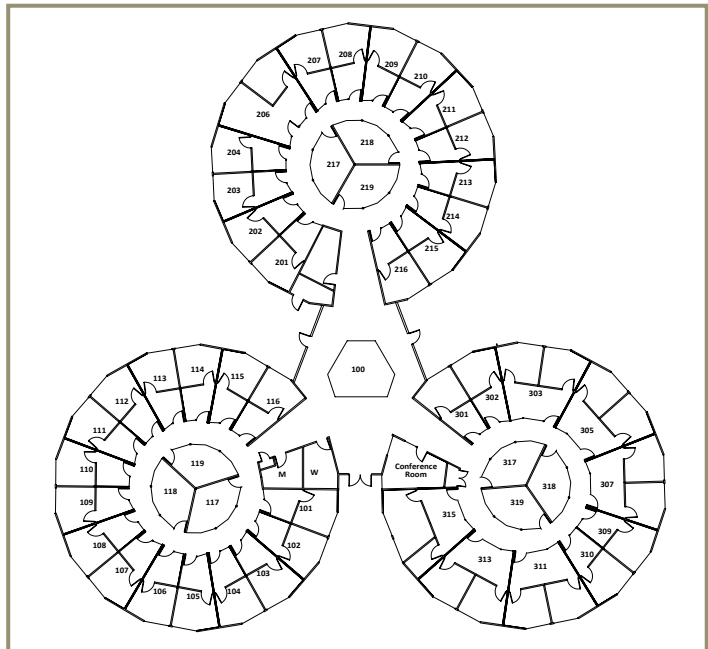



## EXECUTIVE SUITE

4120 Rio Bravo Dr., EL PASO-WEST/CENTRAL

**IMMEDIATELY  
AVAILABLE FOR LEASE  
APPROX. 205 RSF  
PROFESSIONAL OFFICE**

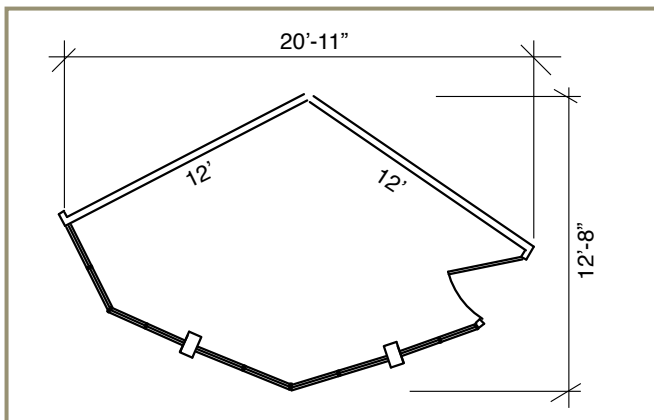

### CLASS A OFFICE SPACE

- Large And Quiet Private Office in One Story Building with Three Entries
- Tenant Shared Conference Room and Break Room in Same Building
- Personal Thermostat in Each Office

