

# NOW LEASING AND SELLING

## Flex spaces that work for you

Office Flex | High visibility Retail storefronts

## Prime Office Flex Spaces, Leander

 15901 Ronald Reagan Blvd, Leander, TX 7841

**1,650 - 35,636 SF of flex space available**  
**For your business**



## BUILDING 2

Unit	SQFT	Status
200	2369	Lease
205	2369	Lease
210	1650	Sale/Lease
215	1650	Sale/Lease
220	1650	Sale/Lease
225	1650	Sale/Lease
230	1650	Sale/Lease
235	1650	Sale/Lease
240	1650	Sale/Lease
245	1650	Sale/Lease
250	1650	Sale/Lease
255	1650	Sale/Lease
260	1650	Sale/Lease
265	1650	Sale/Lease
270	1650	Sale/Lease
275	1650	Sale/Lease
280	1650	Sale/Lease
285	1650	Sale/Lease
290	2249	Sale/Lease
295	2369	Sale/Lease

# From SHELL CONDITION UNIT



# To



**BASIC FINISH OUT**



**MID VARIANT FINISH OUT**



**HIGH END FINISH OUT**

**Level up your business. Fit to choose**

# PROJECT HIGHLIGHTS

**Brand New Delivery:** Recently completed office + warehouse + mezzanine combo.

**Prime Location:** High-traffic visibility just outside Austin, TX.

**Booming Area:** Directly in front of 2,500+ new homes under development.

**Multi-Use Potential:** Ideal for office, light industrial, storage, or creative flex use.

**Flexible Layout:** Modern Design with adaptable layouts including office space, open warehouse, and built-in mezzanine.

**Businesses Around:** Includes office space, open warehouse, and built-in mezzanine.

## SPACE SPECIFICATIONS

**Clear Height: 25'**

**Ceiling Height (Max): 23'**

**Under Mezzanine Height: 10'**

**Standard Parking Spaces:**

bldg 4 - 60 and 2 loading areas

bldg 2 - 60 and 2 loading areas



# SITE PLAN

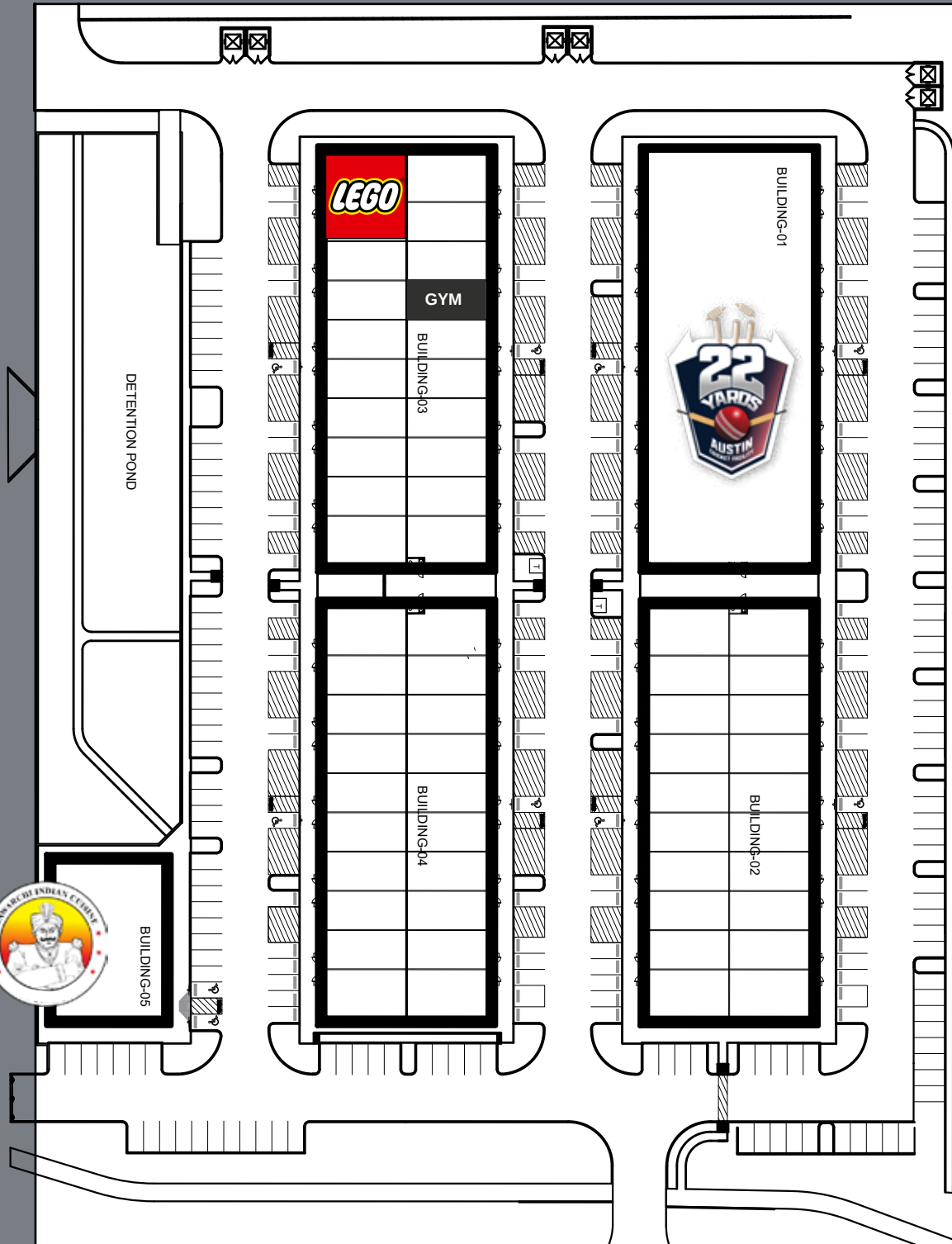

**RONAL REAGAN BLVD**

# BUILDING 2

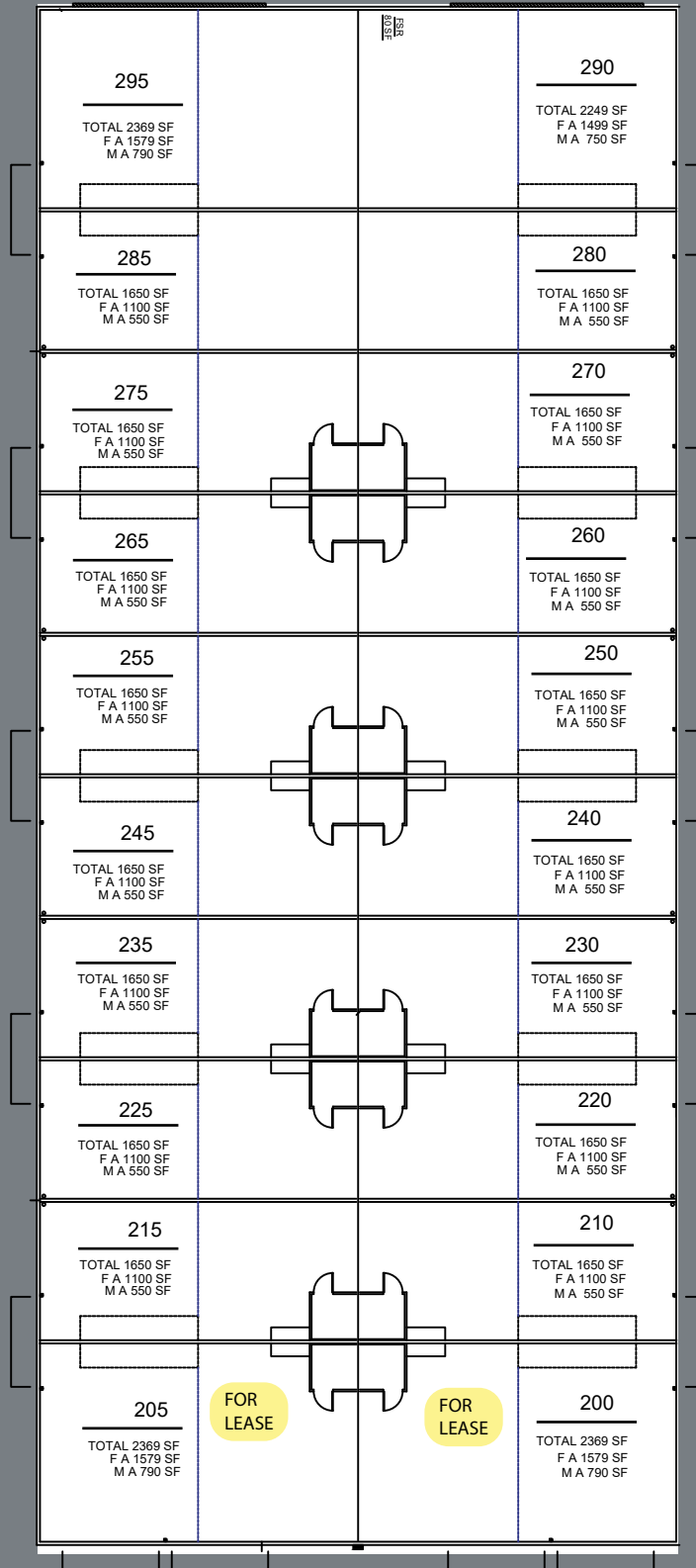

# BUILDING 4

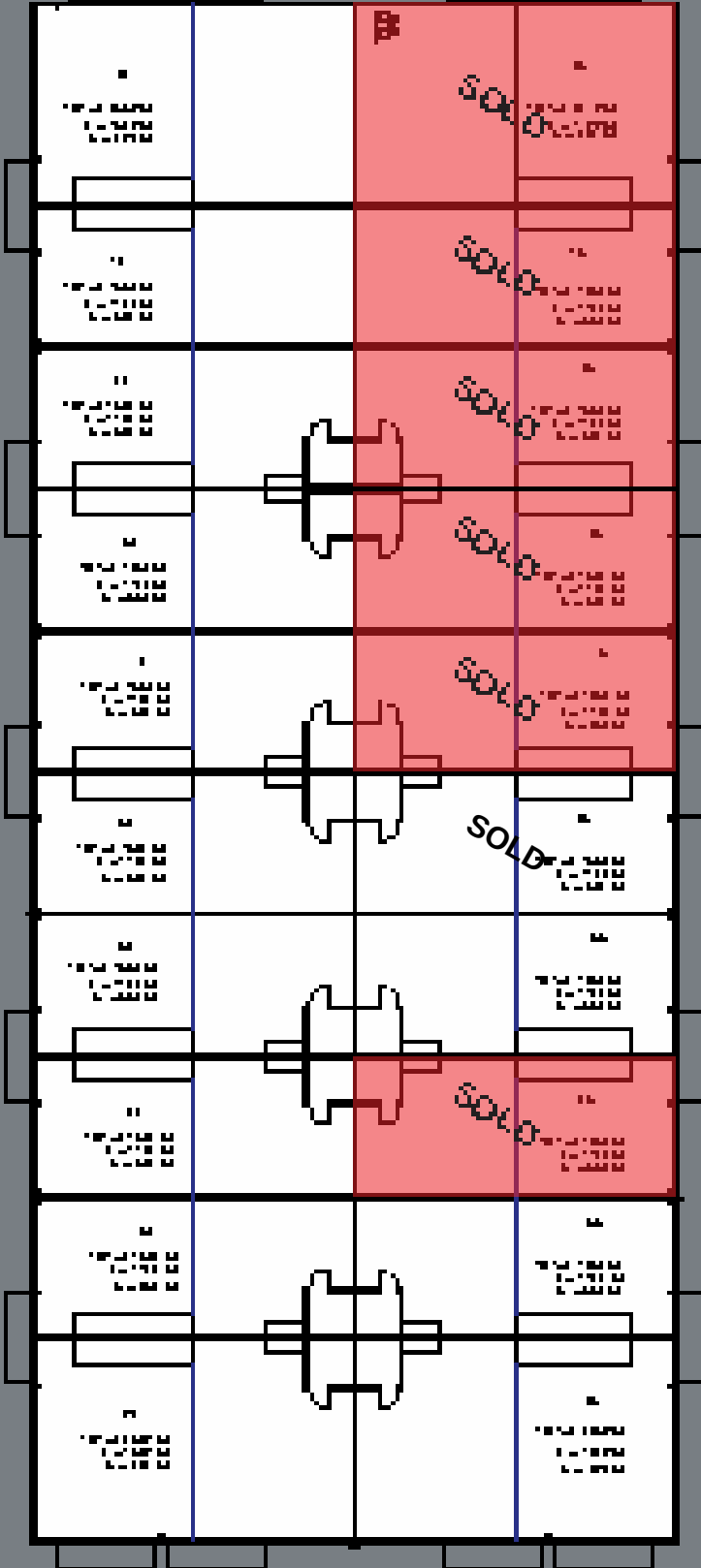



**To know more reach out to us  
512-761-8025 | 9372687929  
www.theprimedeveloper.com  
sales@theprimedeveloper.com**