

9478 W. Fairview Avenue, Boise, ID, 83704

Building C, in West Valley Business Center



SPACE DETAILS

SPACE: 637 SF
AVAILABLE: Occupied, contact for tour
ACCESS: Private entry on south side
LAYOUT: Glass frontage, large open work area with solid surface flooring, built in counter and cabinets. Common break area and restrooms

PROPERTY FEATURES

BLDG TYPE: Office
MANAGED: 14,236 Square Feet (condo)
FLOORS: Single Level
PARKING: 4.5/1,000 SF Leased, included
LEASE TYPE: Full Service, Less Tenant Janitorial
ZONING: City of Boise, C-2D

HIGHLIGHTS

- West Valley Business Center is located on Fairview Avenue in West Boise
- Excellent building signage available
- Abundant service and food amenities in the immediate area
- Public bus stop on Fairview Avenue
- Managed by Sundance, extremely responsive property management

SITE MAP



Call: 208-322-7300

WWW.SUNDANCECO.COM



9478 W. Fairview Avenue, Boise, ID, 83704

Building C, in West Valley Business Center



Call: 208-322-7300

WWW.SUNDANCECO.COM



9478 W. Fairview Avenue, Boise, ID, 83704

Building C, in West Valley Business Center

Floor Plan 678 SF

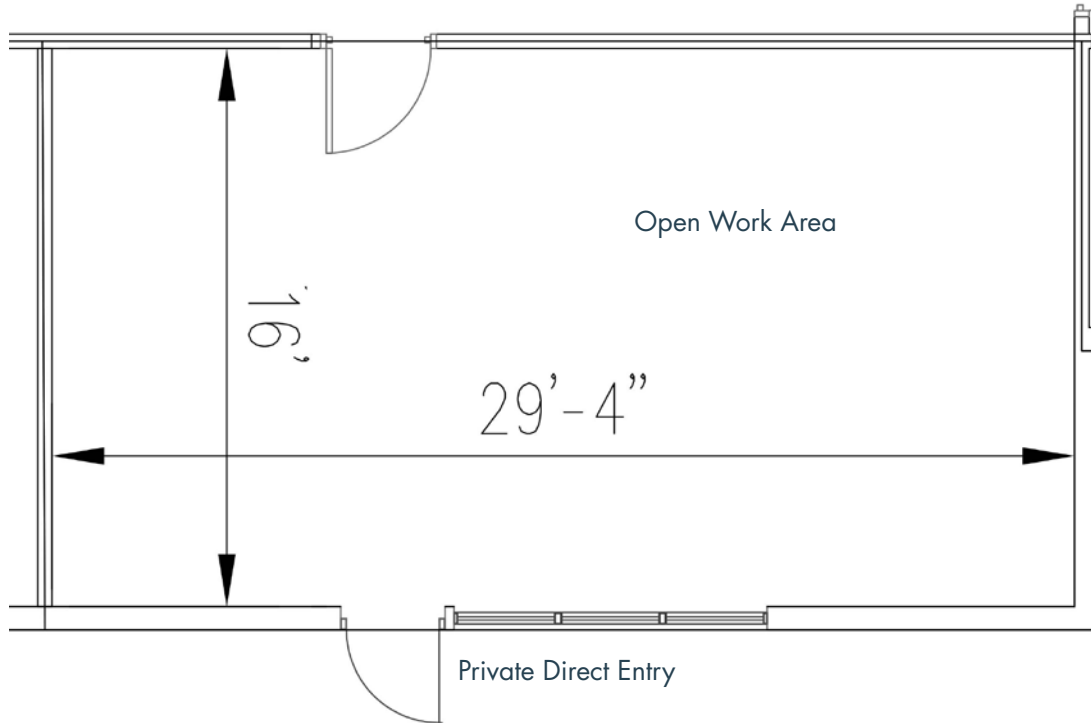

Building Plan

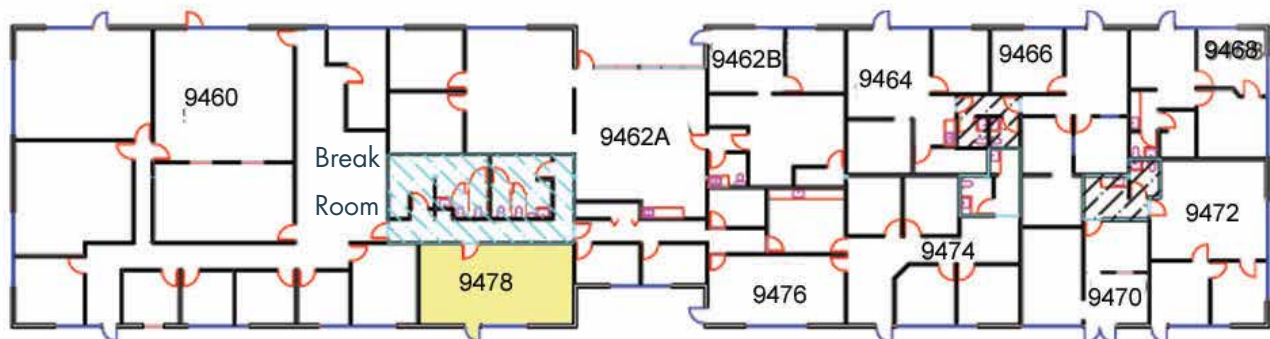

Call: 208-322-7300

WWW.SUNDANCECO.COM

