

BROADWAY TRADE CENTER

9929 BROADWAY STREET | SAN ANTONIO, TX 78217

FOR LEASE

2 Months Free Base Rent
on 3 year term for
spaces <3,000 SF
leased in the next 60 Days

For More
Information
Contact

Justin Roberts

Vice President

+1 210 841 3228

justin.roberts@cbre.com

Brad O'Neill

Vice President

+1 210 253 6070

brad.oneill@cbre.com



CBRE

Property Overview

MOVE-IN READY CONDITION

AVAILABILITY

- ±203,651 Total SF
- Range of sizes available: ±1,232 SF - ±9,704 SF

BUILDING FEATURES

- 20' clear height
- Grade level and dock high loading

HVAC

- Landlord assumes all HVAC responsibility: \$0.50 PSF

TERMS

- Lease Rate: \$12.50-\$13.50 PSF
- Annual OPEX: \$5.46 PSF



LOCATION OVERVIEW

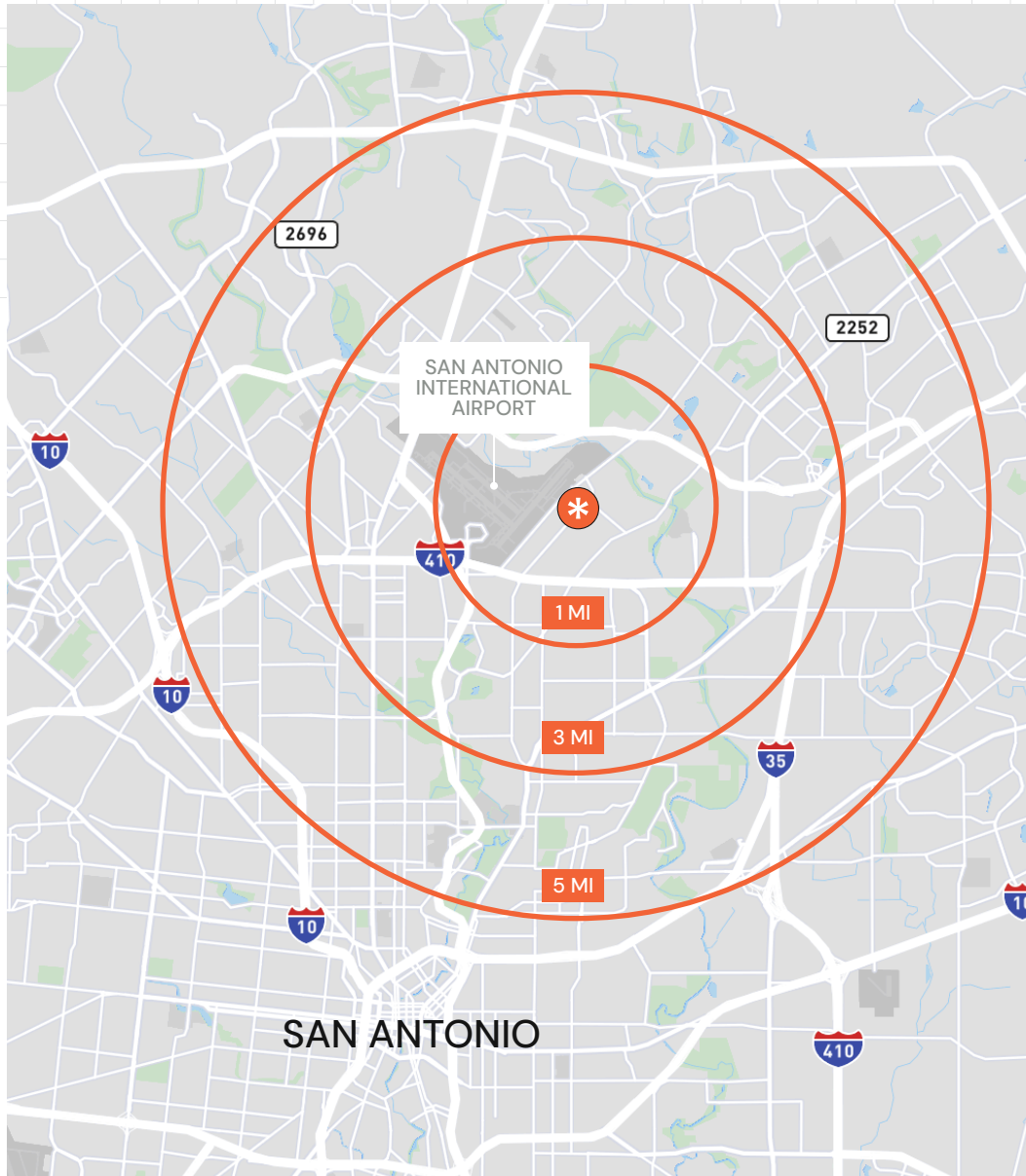

DEMOGRAPHICS

	1 Mile	3 Miles	5 Miles
2025 Population	6,117	83,663	261,616
2025 Employees	13,543	85,602	179,796
2025 Businesses	1,112	7,577	16,422
2025 Average Household Income	\$81,591	\$101,242	\$103,831
2025 Daytime Population	17,251	145,331	351,971



BLDG A

10103 – 10123

SUITE	A10109
SF	±2,130 SF
RATE	\$13.50 NNN
BUILD OUT	Contact Broker
LOADING	1 Dock Door
COMMENTS	Available 7/1/2026

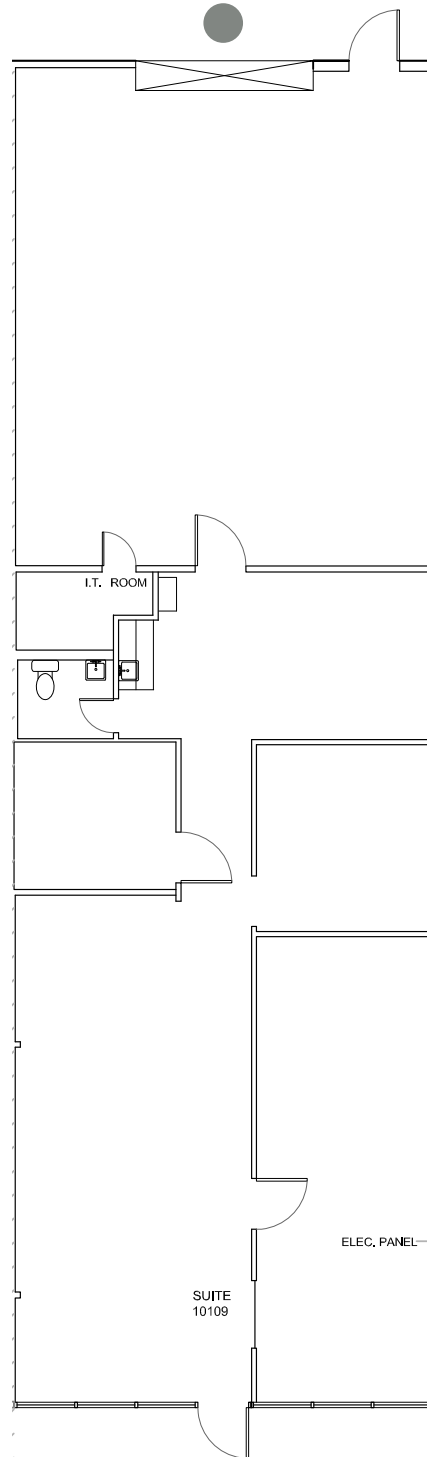

BLDG A

10103 – 10123

SUITE	A10113
SF	±2,115 SF
RATE	\$13.50 NNN
BUILD OUT	Contact Broker
LOADING	1 Grade Level Door
COMMENTS	Available Now

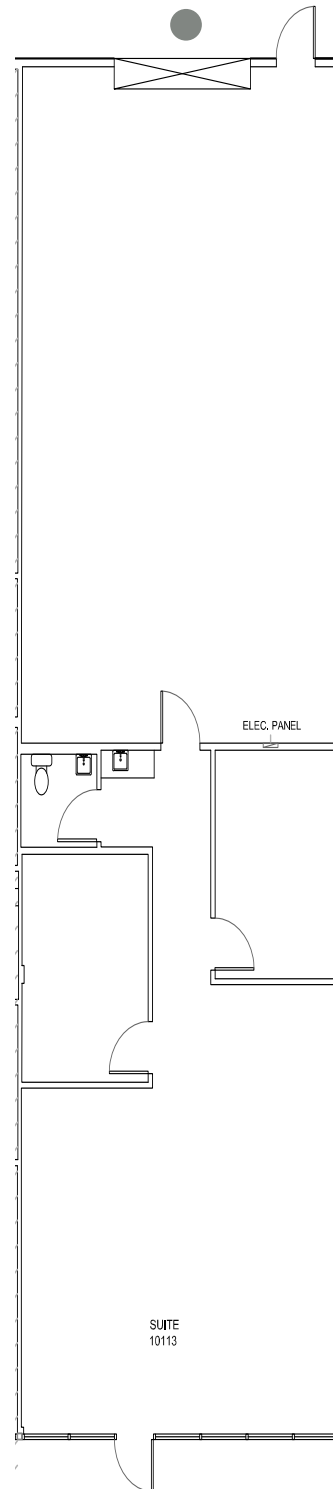

BLDG B

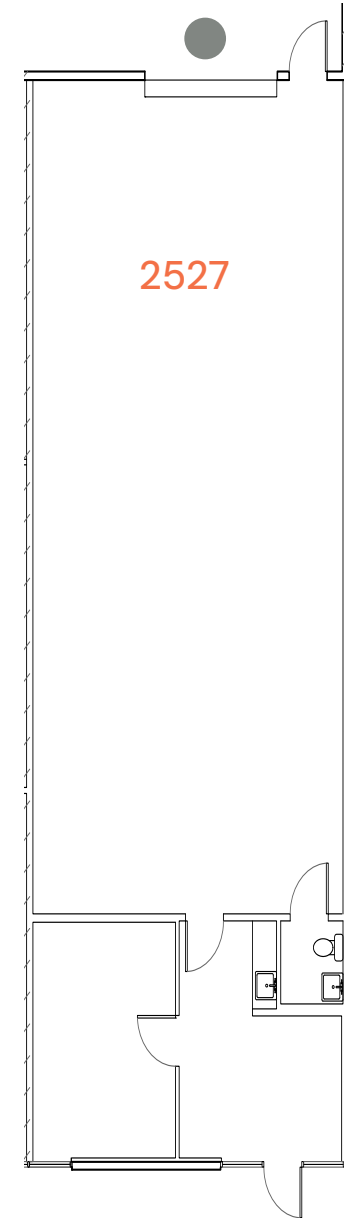
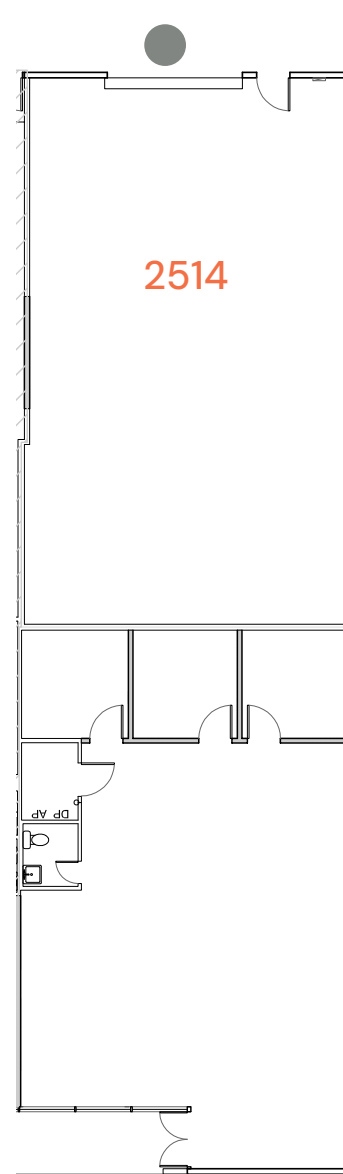

SUITE	B2514	B2527
SF	±2,988 SF	±1,615 SF
RATE	\$13.50 NNN	\$13.50 NNN
BUILD OUT	Office: 1,498 SF Warehouse: 1,490 SF	Office: 371 SF Warehouse: 1,244 SF
LOADING	1 Grade Level Door	1 Grade Level Door
COMMENTS	Available Now	Available Now

BLDG C

2503 - 2523

SUITE	C2507
SF	±1,946 SF
RATE	\$13.50 NNN
BUILD OUT	Office: 911 SF Warehouse: 1,035 SF
LOADING	1 Grade Level Door
COMMENTS	Available Now

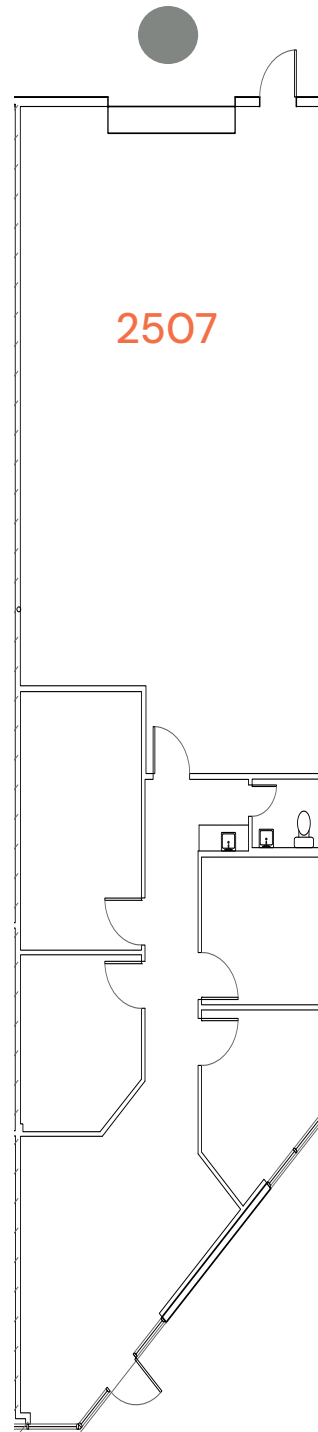

BLDG C

2503 - 2523

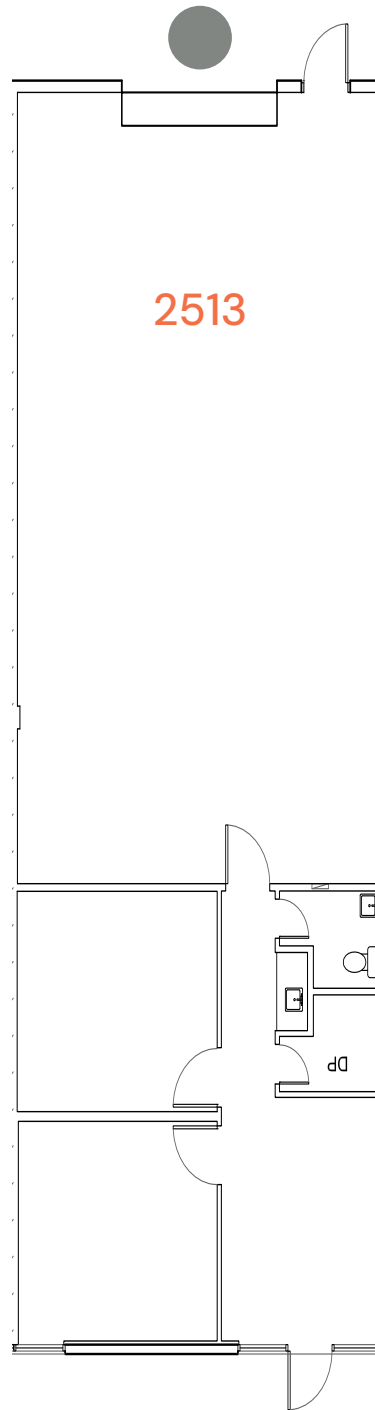

Contiguous Option: ±3,273 SF

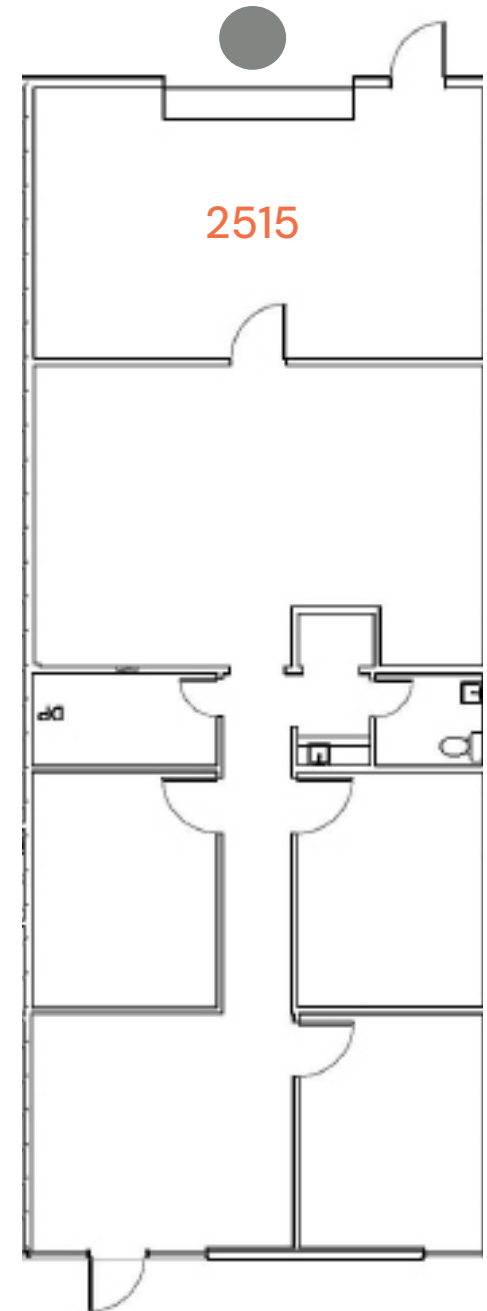

SUITE	C2513	C2515
SF	±1,630 SF	±1,643 SF
RATE	\$13.50 NNN	\$13.50 NNN
BUILD OUT	Office: 597 SF Warehouse: 1,033 SF	Office: 1,247 SF Warehouse: 396 SF
LOADING	1 Grade Level Door	1 Grade Level Door
COMMENTS	Available Now	Available Now

BLDG D

2463 - 2469



SUITE	D2463
SF	±9,704 SF
RATE	\$12.50 NNN
BUILD OUT	±3,867 SF Office ±5,837 SF Warehouse
LOADING	3 Dock High Doors
COMMENTS	30 Days Notice

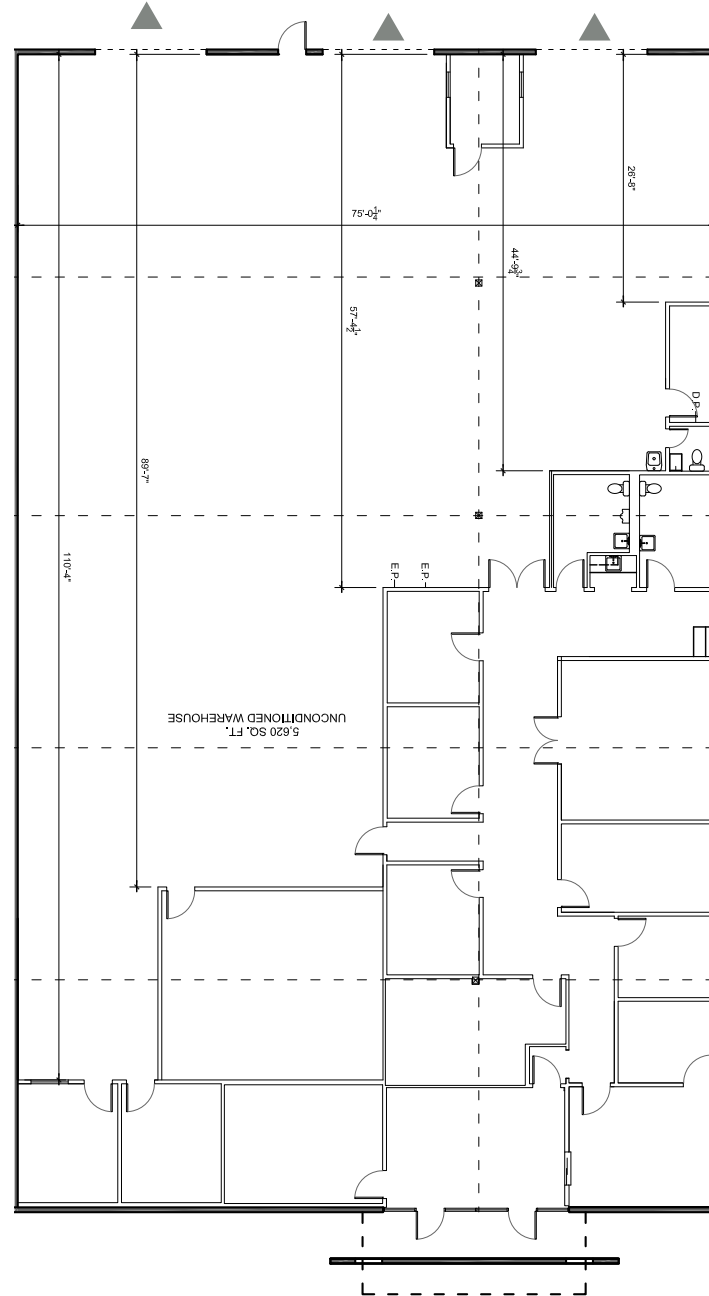

BLDG F

2538 - 2564

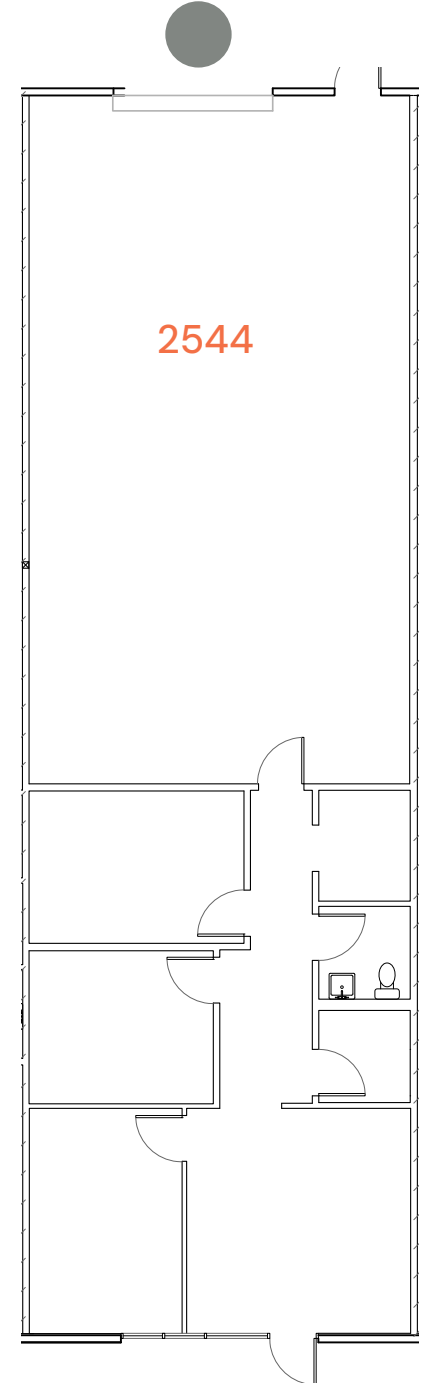
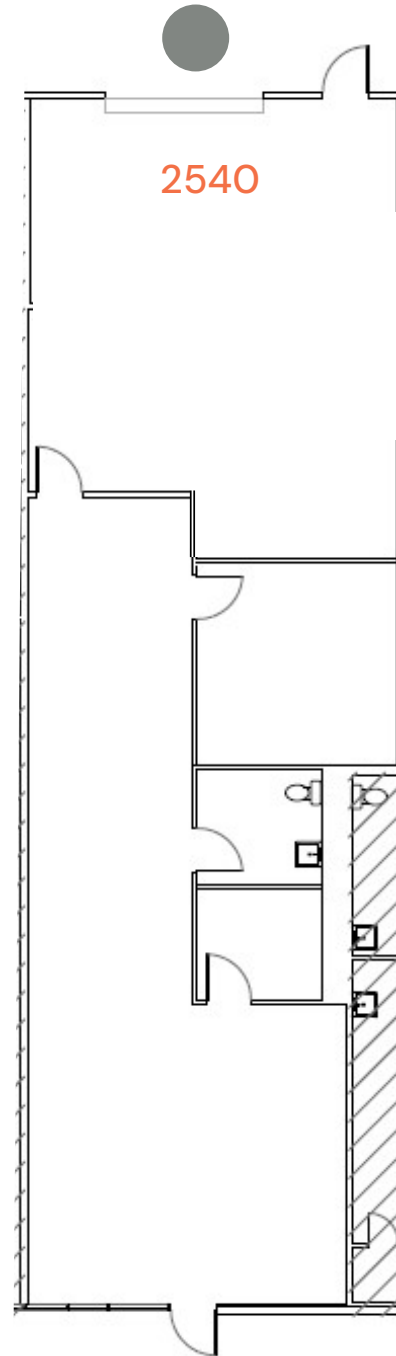

SUITE	F2540	F2544
SF	±1,903 SF	±2,039 SF
RATE	\$13.50 NNN	\$13.50 NNN
BUILD OUT	Office: 905 SF Warehouse: 1,134 SF	Office: 905 SF Warehouse: 1,134 SF
LOADING	1 Grade Level Door	1 Grade Level Door
COMMENTS	Available Now	Available Now

BLDG F

2538 - 2564

SUITE	F2558
SF	±1,232 SF
RATE	\$13.50 NNN
BUILD OUT	Office: 226 SF Warehouse: 1,006 SF
LOADING	1 Grade Level Door
COMMENTS	Available Now

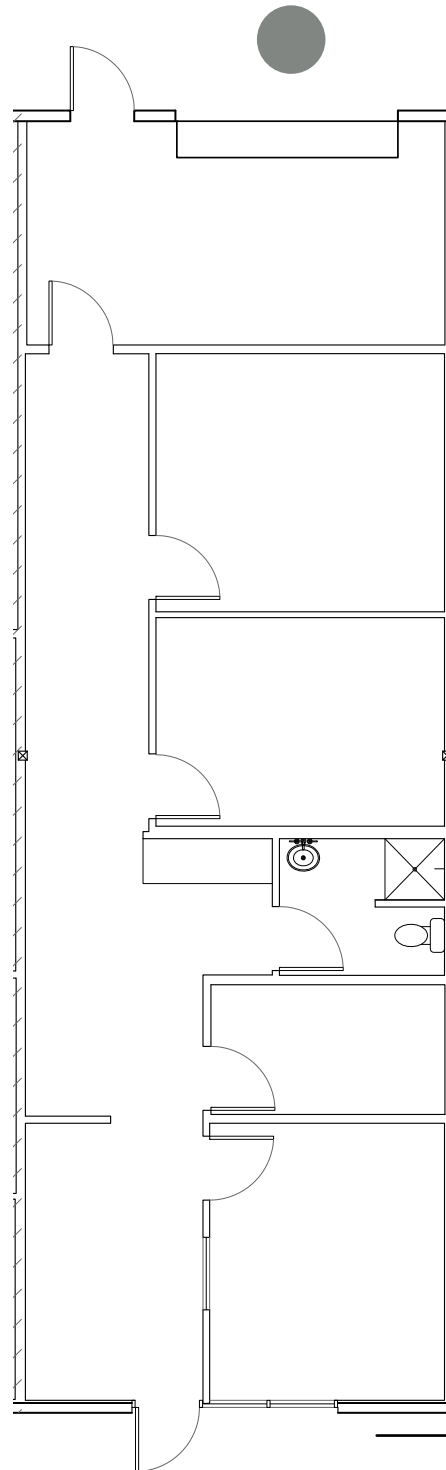

BROADWAY TRADE CENTER

9929 BROADWAY STREET | SAN ANTONIO, TX 78217

FOR LEASE



For More
Information
Contact

Justin Roberts

Vice President

+1 210 841 3228

justin.roberts@cbre.com

Brad O'Neill

Vice President

+1 210 253 6070

brad.oneill@cbre.com



CBRE

© 2026 CBRE, Inc. All rights reserved. This information has been obtained from sources believed reliable but has not been verified for accuracy or completeness. CBRE, Inc. makes no guarantee, representation or warranty and accepts no responsibility or liability as to the accuracy, completeness, or reliability of the information contained herein. You should conduct a careful, independent investigation of the property and verify all information. Any reliance on this information is solely at your own risk. CBRE and the CBRE logo are service marks of CBRE, Inc. All other marks displayed on this document are the property of their respective owners, and the use of such marks does not imply any affiliation with or endorsement of CBRE. Photos herein are the property of their respective owners. Use of these images without the express written consent of the owner is prohibited.



Information About Brokerage Services

Texas law requires all real estate license holders to give the following information about brokerage services to prospective buyers, tenants, sellers and landlords.

11-03-2025



TYPES OF REAL ESTATE LICENSE HOLDERS:

- **A BROKER** is responsible for all brokerage activities, including acts performed by sales agents sponsored by the broker.
- **A SALES AGENT** must be sponsored by a broker and works with clients on behalf of the broker.

A BROKER’S MINIMUM DUTIES REQUIRED BY LAW (A client is the person or party that the broker represents):

- Put the interests of the client above all others, including the broker’s own interests;
- Inform the client of any material information about the property or transaction received by the broker;
- Answer the client’s questions and present any offer to or counter-offer from the client; and
- Treat all parties to a real estate transaction honestly and fairly.

WRITTEN AGREEMENTS ARE REQUIRED IN CERTAIN SITUATIONS: A license holder who performs brokerage activity for a prospective buyer of residential property must enter into a written agreement with the buyer before showing any residential property to the buyer or if no residential property will be shown, before presenting an offer on behalf of the buyer. This written agreement must contain specific information required by Texas law. For more information on these requirements, see section 1101.563 of the Texas Occupations Code. **Even if a written agreement is not required, to avoid disputes, all agreements between you and a broker should be in writing and clearly establish: (i) the broker’s duties and responsibilities to you and your obligations under the agreement; and (ii) the amount or rate of compensation the broker will receive and how this amount is determined.**

A LICENSE HOLDER CAN REPRESENT A PARTY IN A REAL ESTATE TRANSACTION:

AS AGENT FOR OWNER (SELLER/LANDLORD): The broker becomes the property owner’s agent through an agreement with the owner, usually in a written listing to sell or property management agreement. An owner’s agent must perform the broker’s minimum duties above and must inform the owner of any material information about the property or transaction known by the agent, including information disclosed to the agent by the buyer or buyer’s agent. **An owner’s agent fees are not set by law and are fully negotiable.**

AS AGENT FOR BUYER/TENANT: The broker becomes the buyer/tenant’s agent by agreeing to represent the buyer, usually through a written representation agreement. A buyer’s agent must perform the broker’s minimum duties above and must inform the buyer of any material information about the property or transaction known by the agent, including information disclosed to the agent by the seller or seller’s agent. **A buyer/tenant’s agent fees are not set by law and are fully negotiable.**

AS AGENT FOR BOTH - INTERMEDIARY: To act as an intermediary between the parties the broker must first obtain the written agreement of *each party* to the transaction. The written agreement must state who will pay the broker and, in conspicuous bold or underlined print, set forth the broker’s obligations as an intermediary. A broker who acts as an intermediary:

- Must treat all parties to the transaction impartially and fairly;
- May, with the parties’ written consent, appoint a different license holder associated with the broker to each party (owner and buyer) to communicate with, provide opinions and advice to, and carry out the instructions of each party to the transaction.
- Must not, unless specifically authorized in writing to do so by the party, disclose:
 - that the owner will accept a price less than the written asking price;
 - that the buyer/tenant will pay a price greater than the price submitted in a written offer; and
 - any confidential information or any other information that a party specifically instructs the broker in writing not to disclose, unless required to do so by law.

A LICENSE HOLDER CAN SHOW PROPERTY TO A BUYER/TENANT WITHOUT REPRESENTING THE BUYER/TENANT IF:

- The broker has not agreed with the buyer/tenant, either orally or in writing, to represent the buyer/tenant;
- The broker is not otherwise acting as the buyer/tenant’s agent at the time of showing the property;
- The broker does not provide the buyer/tenant opinions or advice regarding the property or real estate transactions generally; and
- The broker does not perform any other act of real estate brokerage for the buyer/tenant.

Before showing a residential property to an unrepresented prospective buyer, a license holder must enter into a written agreement that contains the information required by section 1101.563 of the Texas Occupations Code. The agreement may not be exclusive and must be limited to no more than 14 days.

LICENSE HOLDER CONTACT INFORMATION: This notice is being provided for information purposes. It does not create an obligation for you to use the broker’s services. Please acknowledge receipt of this notice below and retain a copy for your records.

Name of Sponsoring Broker (Licensed Individual or Business Entity)	License No.	Email	Phone
Name of Designated Broker of Licensed Business Entity, if applicable	License No.	Email	Phone
Name of Licensed Supervisor of Sales Agent/Associate, if applicable	License No.	Email	Phone
Name of Sales Agent/Associate	License No.	Email	Phone

Buyer/Tenant/Seller/Landlord Initials

Date