

MEASURED PER BOMA
2010 OFFICE STANDARD

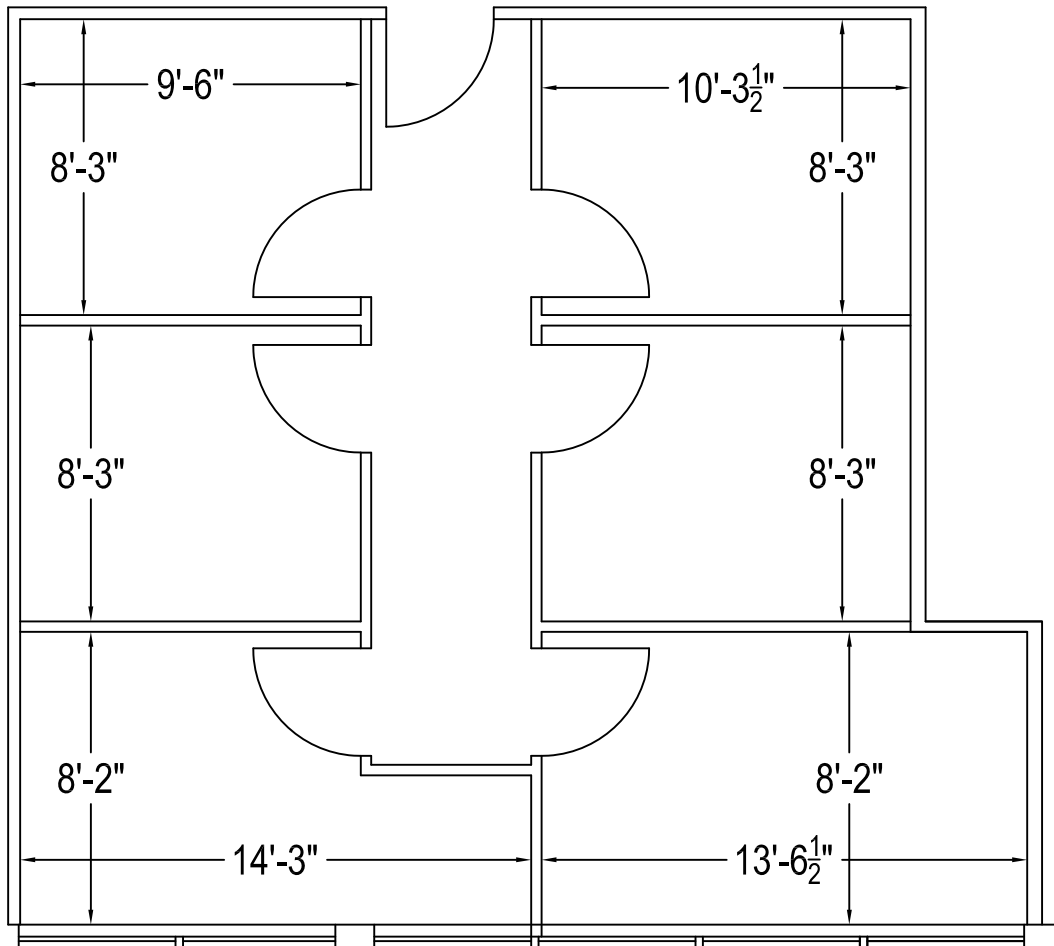

DIMENSIONS ARE FOR SPACE
PLANNING PURPOSES ONLY



THIS IS TO CERTIFY THE AREA SHOWN ON THIS PLAN WAS DETERMINED FROM FIELD MEASUREMENT, AND FURTHER THAT THE AREA SHOWN IS IN COMPLIANCE WITH BOMA STANDARD ANSIZ.65.1-1996

SUITE 220

RENTABLE AREA: 804 SF

<p>PREPARED BY:</p>  <p>measurex.ca</p>	<p>LOCATION:</p> <p>SECOND FLOOR 650 KING STREET EAST OSHAWA, ONTARIO</p>		<p>PREPARED FOR: SUMMERS AND CO.</p> <p>DATE: AUGUST 15, 2021</p> <p>FILE: 640KINGE.dwg SCALE: NTS</p>
--	---	---	---