

FOR SALE OR LEASE

**134,094 SF Available**  
Divisible to 20,000 SF

**101 W. RISINGER RD.**  
Fort Worth, TX



For information please contact:

**Weston King**

*Director*

Weston.King@nrmk.com

830-214-5335

**Dalton.Knipe**

*Director*

Dalton.Knipe@nrmk.com

972-632-6911

**NEWMARK**





## SITE PLAN



### 101 W. Risinger Rd.

- » 134,094 SF New Construction
- » Rear Load Configuration
- » Divisible to 20k SF
- » 32' clear
- » 3,028 SF of spec office



### Site

- » 156 Car Parks
- » 130' Truck Court
- » 5" thick concrete paving in auto parking areas
- » 6" thick concrete in standard passenger vehicle drive aisles
- » 7" heavy-duty concrete in truck drive aisles, loading courts, and apron areas



### Shell

- » 6" Slab
- » 38 dock-high overhead doors (9' x 10')
- » 4 oversized drive-in doors (12' x 14') with ramps
- » ESFR fire sprinkler system
- » White-box warehouse interior
- » (2) 40,000 lb capacity dock levelers
- » LED high-bay lighting
- » Sealed concrete floors with durable Diamond Hard finish
- » Premium joint sealing system
- » Treated slab joints
- » Mechanical ventilation system. Exhaust fans for one air change per hour
- » Dock Face with Clerestory Windows



### Power

- » High-capacity power with 1,500 kVA transformer and 3,000-amp service

FOR SALE  
OR LEASE



134,094 SF  
Available

101 W. Risinger Rd.  
Fort Worth, TX

SPEC  
OFFICE  
PLAN

NEWMARK

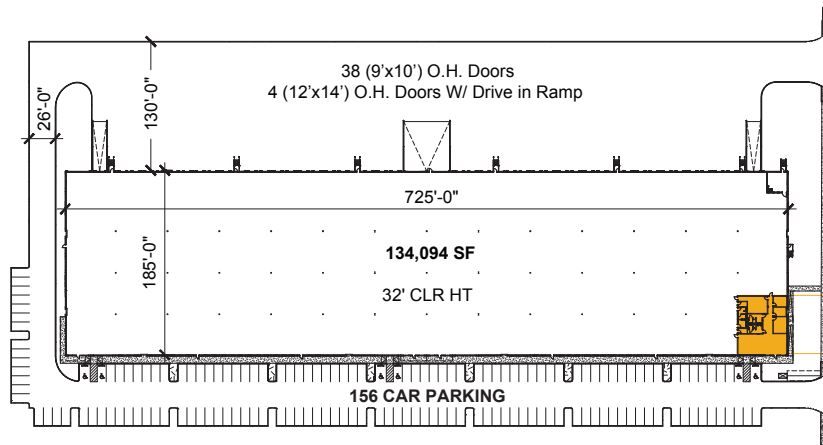

OFFICE ±3,028 SF

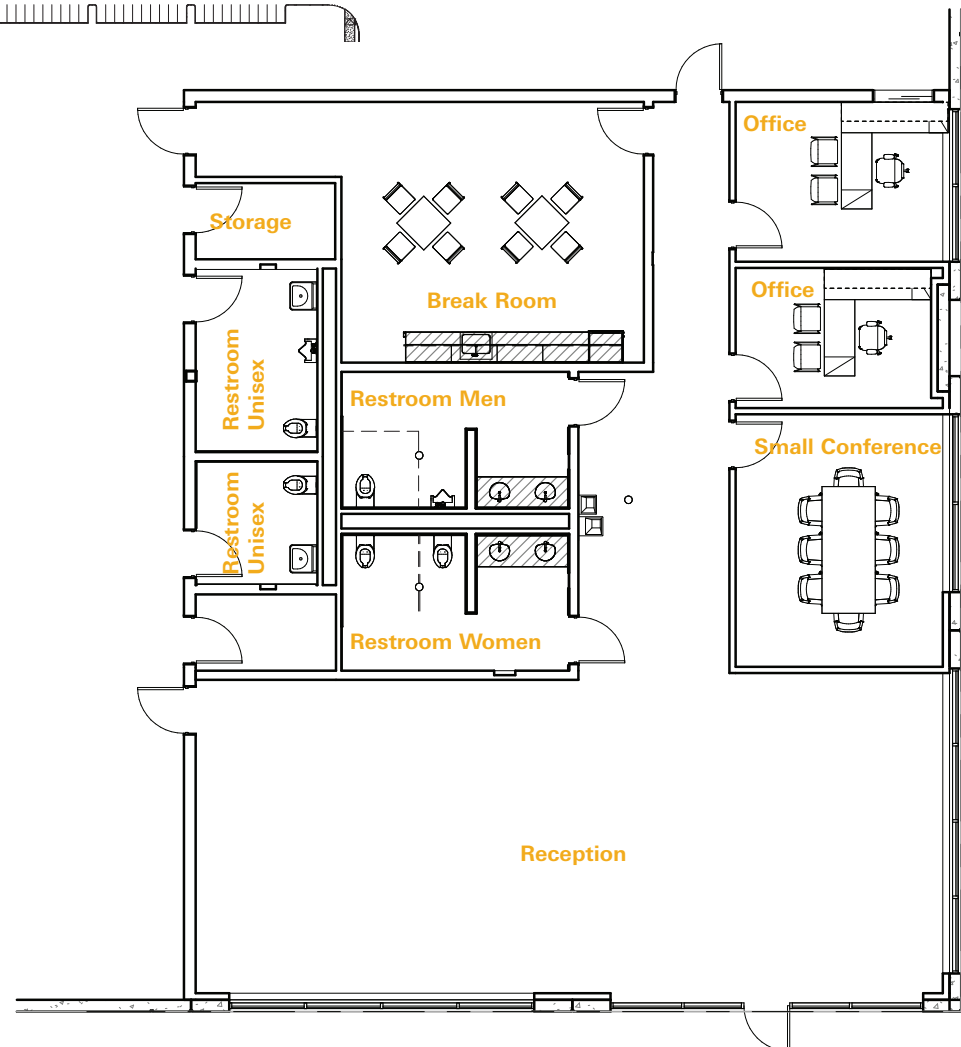

FOR SALE  
OR LEASE



134,094 SF  
Available

101 W. Risinger Rd.  
Fort Worth, TX

ACCESS

NEWMARK



— Ingress  
— Egress

FOR SALE  
OR LEASE



134,094 SF  
Available

101 W. Risinger Rd.  
Fort Worth, TX

CORPORATE  
NEIGHBORS

NEWMARK



FOR SALE  
OR LEASE



134,094 SF  
Available

101 W. Risinger Rd.  
Fort Worth, TX

DRIVING  
DISTANCES

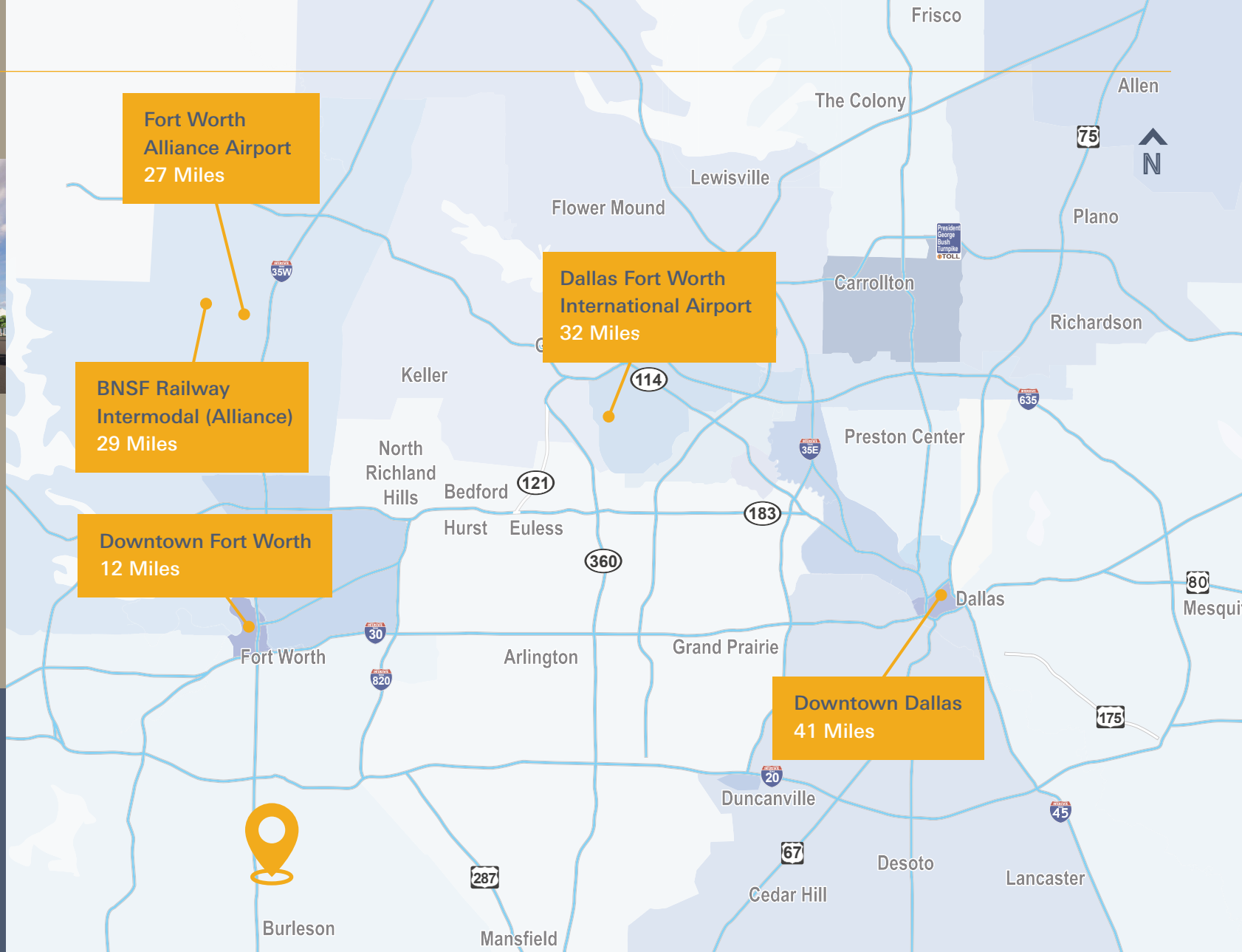

For information please contact:

**Weston King**

*Director*

Weston.King@nmrk.com

830-214-5335

**Dalton.Knipe**

*Director*

Dalton.Knipe@nmrk.com

972-632-6911

NMRK.COM

**Dallas**

2601 Olive Street | Suite 1600

Dallas, Texas 75201

**NEWMARK**