

15300 - 15311 33rd Ave S

SeaTac, WA 98188

RETAIL/OFFICE FOR LEASE



**cannon
commercial**



 SOUNDTRANSIT

 POLARIS
AT SEATAC

 ADARA
at SeaTac

EXECUTIVE SUMMARY

The Opportunity

Cannon Commercial is pleased to present cost effective commercial spaces for lease in the hub of SeaTac, offering excellent visibility and convenient access. The location is situated near major transportation hubs, including Seattle-Tacoma International Airport and Sound Transit Light Rail. Leverage this opportunity to establish your business in a dynamic and growing market.



Address: 15300 33rd Ave S SeaTac WA 98188

Lease Rate: \$16 - \$18/SF/YR

NNN: approx. \$8/SF/YR

Available Suites: #100 : 1,040 SF

#136 : 1,248 SF

#146 : 895 SF

#212 : 2,119 SF

Address: 15311 33rd Ave S SeaTac WA 98188

Lease Rate: \$16 - \$18/SF/YR

NNN: approx. \$8/SF/YR

Available Suites: #101 : 1,275 SF

#111 : 1,296 SF *shaft for type1 hood

#121 : 956 SF *shaft for type1 hood

#151 : 1,040 SF

PROPERTY HIGHLIGHTS

Reserved Monthly Parking Available

Up to 4 parking stalls available per space. Please inquire about pricing.

Fully Leased Apartments

Benefit from 365 fully leased apartments at Polaris and 220 fully leased apartments at Adara.

11 out of 19 Commercial Spaces Leased

Building Tenants include:

- Jewelery Store
- Men's & Women's Clothing Store
- Boulevard Market
- Pizza Station
- Barbershop
- Mediterranean Restaurant
- Tukwila Station Pharmacy
- Golden Stars Early Learning Center
- SeaTac Police Substation



Mins. to Light Rail Station

5

Mins. to SeaTac Airport

5

Mins. to WestField Mall

5

Mins. to Seattle

20

Mins. to Bellevue

25

Mins. to Tacoma

35

	1 Mile	3 Mile	5 Mile
Population	15,409	92,594	245,362
Households	5,211	33,728	91,563
Avg. HH Income	\$90,471	\$98,518	\$105,757
Median HH Income	\$72,582	\$75,857	\$81,695

PHOTO GALLERY



SEA Seattle-Tacoma
International
Airport

ADARA
at SeaTac

POLARIS
AT SEATAC



FLOOR PLAN

Polaris

#100

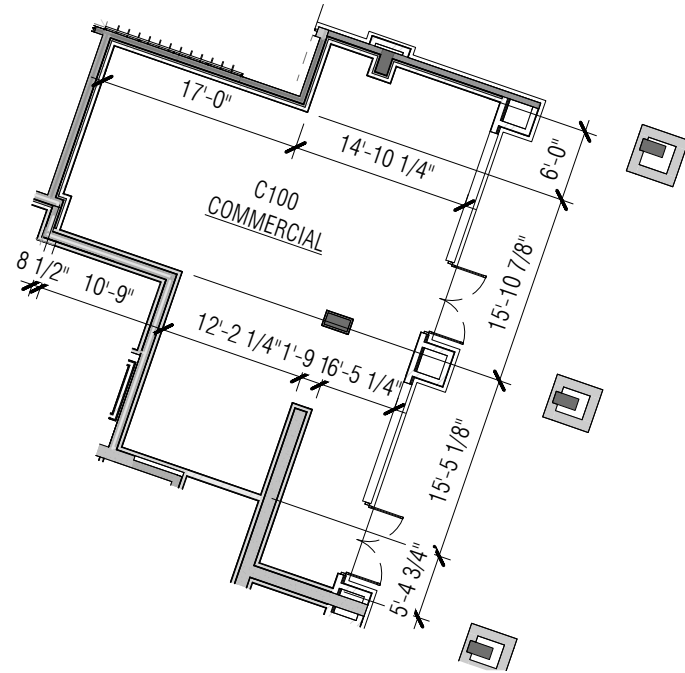

#146

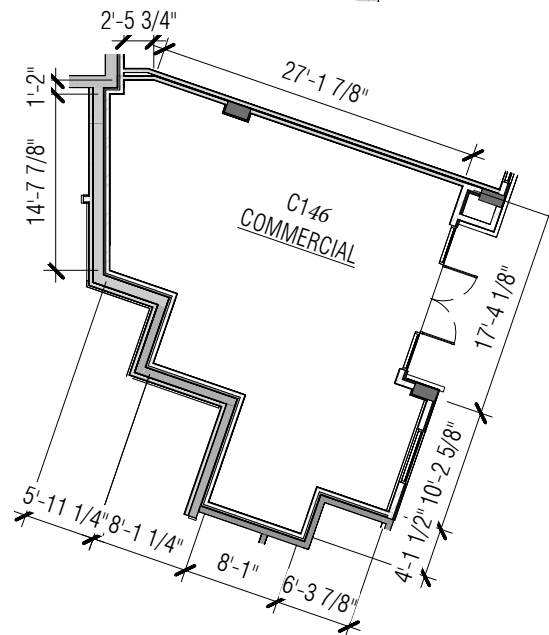

#136

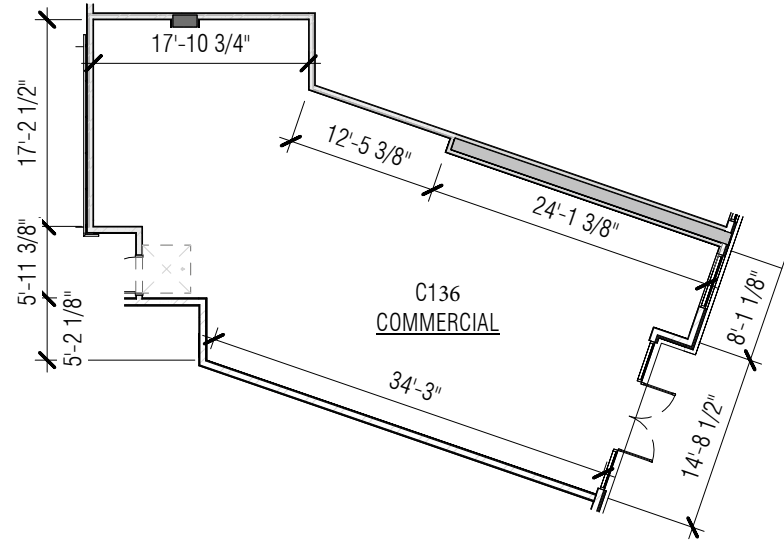

#212

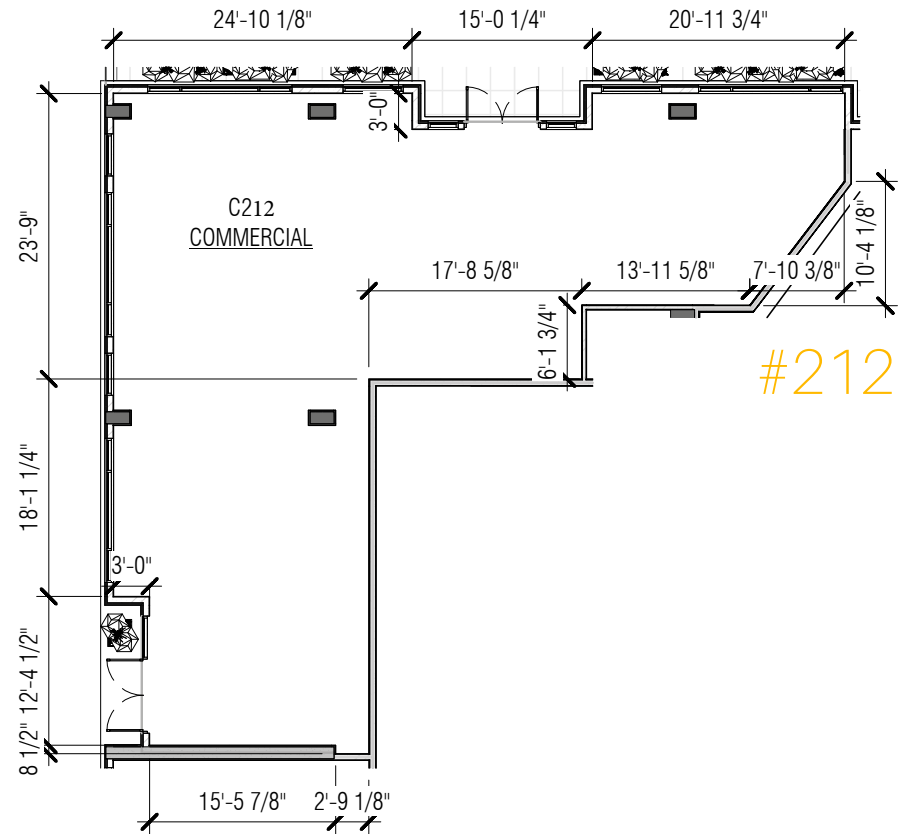

FLOOR PLAN

Adara

#121

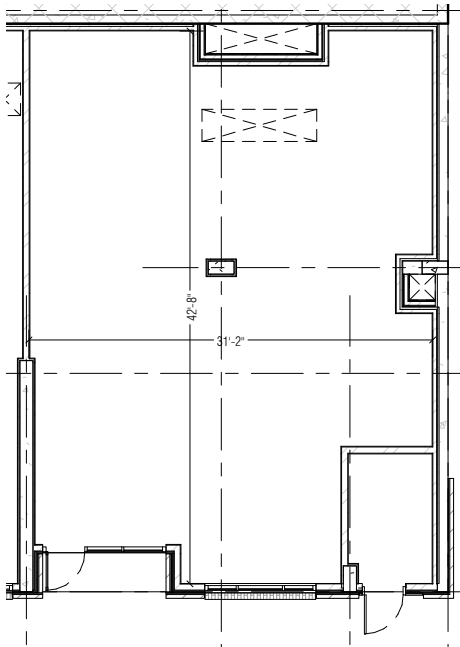

#101

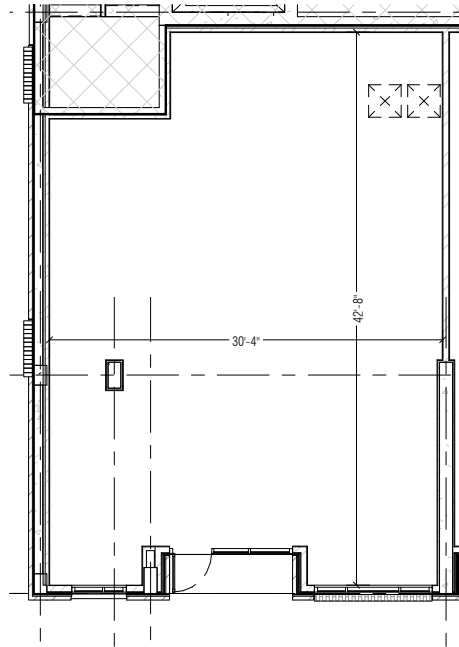

#111

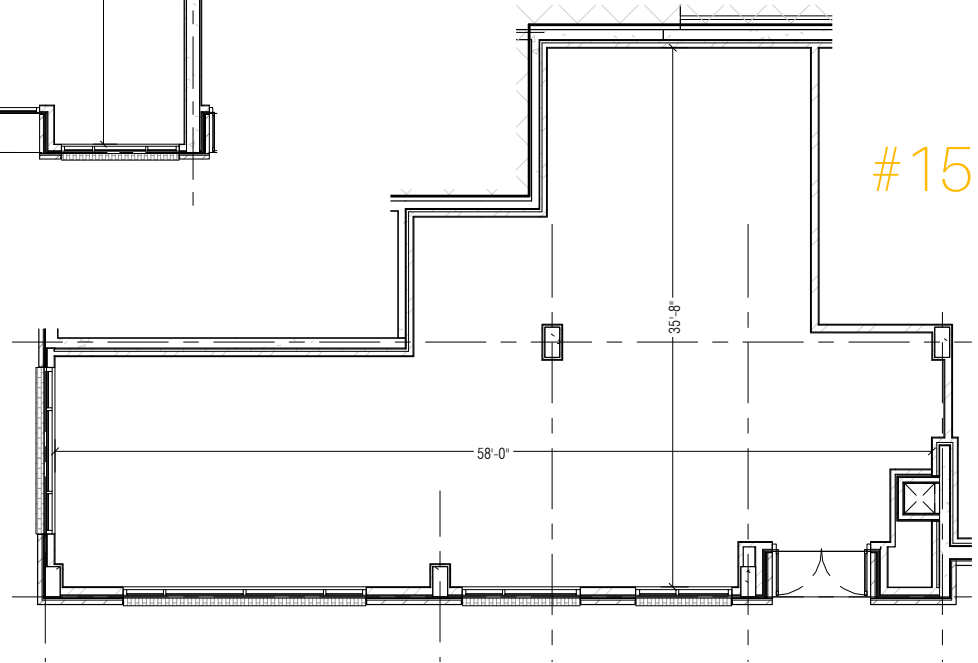
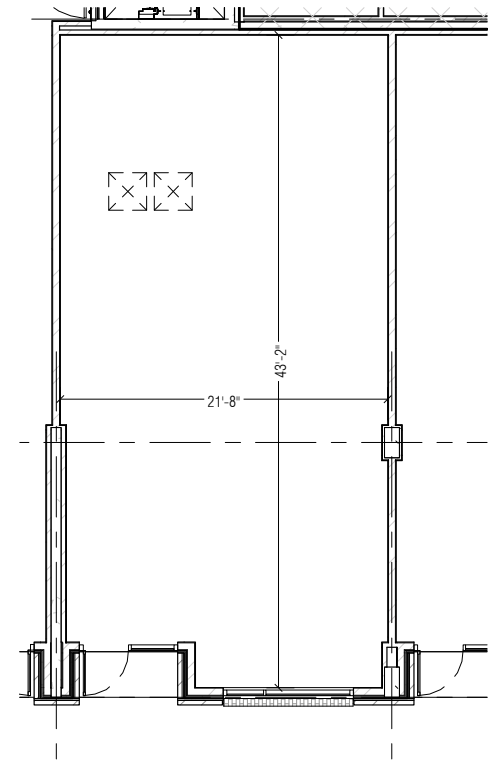

#151

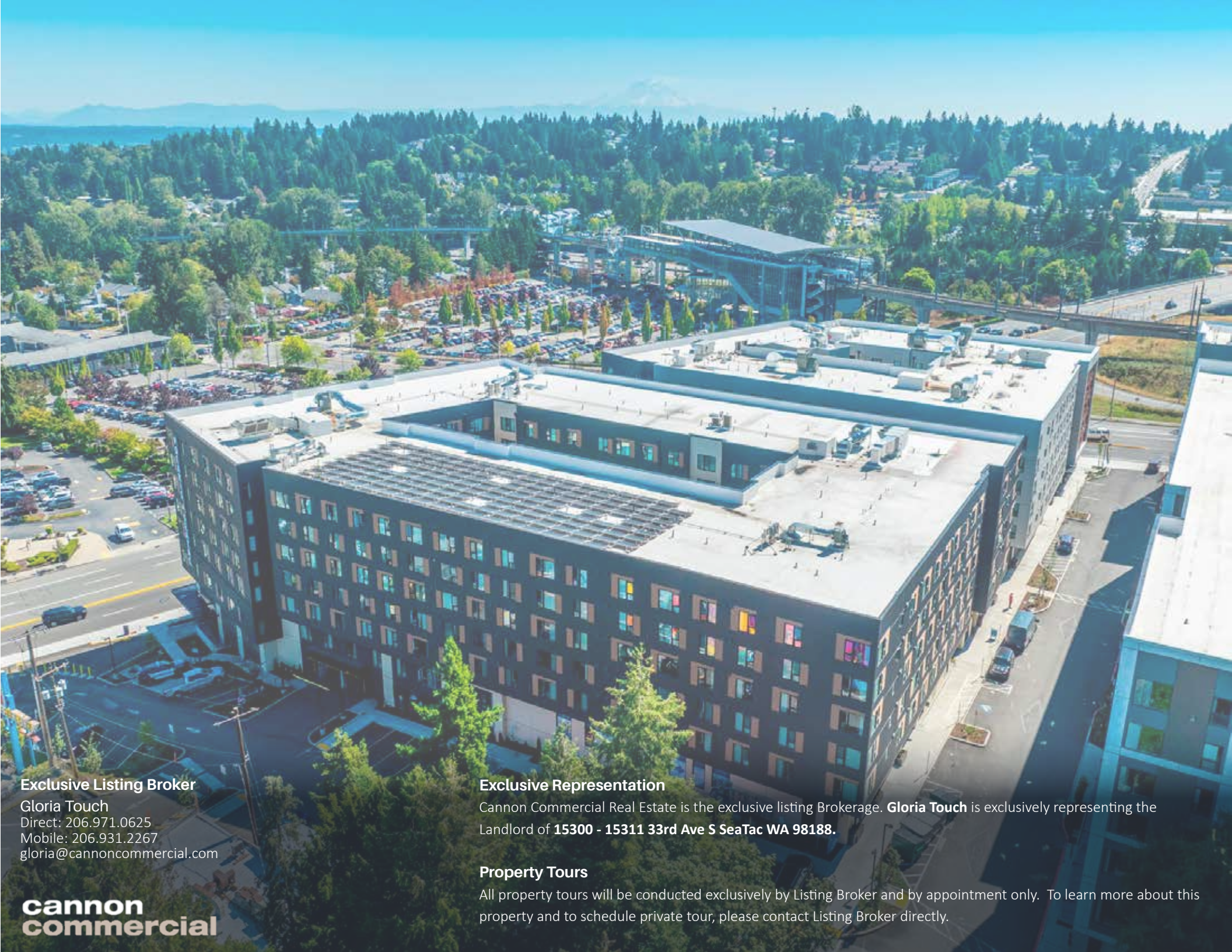

Exclusive Listing Broker

Gloria Touch
Direct: 206.971.0625
Mobile: 206.931.2267
gloria@cannoncommercial.com

Exclusive Representation

Cannon Commercial Real Estate is the exclusive listing Brokerage. **Gloria Touch** is exclusively representing the Landlord of **15300 - 15311 33rd Ave S SeaTac WA 98188.**

Property Tours

All property tours will be conducted exclusively by Listing Broker and by appointment only. To learn more about this property and to schedule private tour, please contact Listing Broker directly.

**cannon
commercial**