

OFFERING MEMORANDUM



MOB | Single Tenant NNN |  OneOncology™ | 1625 Ramblewood Dr, East Lansing, MI

CALL FOR OFFERS | Tuesday, July 14th | 12 P.M.



NAI Mid-Michigan

2149 Jolly Rd. Suite 200, Okemos, MI 48840

517 - 487 - 9222

www.naimidmichigan.com

PREPARED BY:

JEROME ABOOD

Managing Broker

517-281-5800

Executive Summary	3
Lease Summary	4
Lease Overview	5
Tenant Profile	6
Parcel Map	8
Aerial	9
Exterior Photos	10
Interior Photos	11
Floor Plan	12
Area Overview	13
Demographics	14
Contact Information	15

CONFIDENTIALITY & DISCLAIMER

All materials and information received or derived from NAI Mid-Michigan, its directors, officers, agents, advisors, affiliates and/or any third party sources are provided without representation or warranty as to completeness, veracity, or accuracy, condition of the property, compliance or lack of compliance with applicable governmental requirements, developability or suitability, financial performance of the property, projected financial performance of the property for any party's intended use or any and all other matters.

Neither NAI Mid-Michigan, its directors, officers, agents, advisors, or affiliates makes any representation or warranty, express or implied, as to accuracy or completeness of the any materials or information provided, derived, or received. Materials and information from any source, whether written or verbal, that may be furnished for review are not a substitute for a party's active conduct of its own due diligence to determine these and other matters of significance to such party. NAI Mid-Michigan will not investigate or verify any such matters or conduct due diligence for a party unless otherwise agreed in writing.

EACH PARTY SHALL CONDUCT ITS OWN INDEPENDENT INVESTIGATION AND DUE DILIGENCE. Any party contemplating or under contract or in escrow for a transaction is urged to verify all information and to conduct their own inspections and investigations including through appropriate third party independent professionals selected by such party. All financial data should be verified by the party including by obtaining and reading applicable documents and reports and consulting appropriate independent professionals. NAI Mid-Michigan makes no warranties and/or representations regarding the veracity, completeness, or relevance of any financial data or assumptions.

NAI Mid-Michigan does not serve as a financial advisor to any party regarding any proposed transaction. All data and assumptions regarding financial performance, including that used for financial modeling purposes, may differ from actual data or performance. Any estimates of market rents and/or projected rents that may be provided to a party do not necessarily mean that rents can be established at or increased to that level. Parties must evaluate any applicable contractual and governmental limitations as well as market conditions, vacancy factors and other issues in order to determine rents from or for the property.

Legal questions should be discussed by the party with an attorney. Tax questions should be discussed by the party with a certified public accountant or tax attorney. Title questions should be discussed by the party with a title officer or attorney. Questions regarding the condition of the property and whether the property complies with applicable governmental requirements should be discussed by the party with appropriate engineers, architects, contractors, other consultants and governmental agencies. All properties and services are marketed by NAI Mid-Michigan in compliance with all applicable fair housing and equal opportunity laws.

Investment Overview

Address	1625 Ramblewood Drive, Suite 1
City, State, ZIP	East Lansing, MI 48823
Tenant	OneOncology East LLC
Lease Guarantor	OneOncology, LLC
Rentable SF	10,976
Total Building SF (Unit 1 & 2)	17,516
Year Built	1998
Land (Acres)	0.23 (Condo Unit)
Lease Type	NNN
Annual Increases	3.00%
Lease Term	5 Years
Lease Commencement	02-01-2026
Lease Expiration	01-31-2031
Renewal Options	One five-year renewal (continued 3% annual increases)
Data Room	Available with executed Confidentiality Agreement

Location Highlights

- Located in East Lansing, a highly stable, education-driven market.
- Immediate proximity to Michigan State University, one of the largest public universities in the U.S.
- Strong daytime population supported by students, faculty, and university-related employment
- Part of the Lansing–East Lansing metropolitan area, benefiting from a diverse economic base
- Convenient regional access via US-127 and I-496
- Surrounded by established residential neighborhoods and community amenities



Stable & Growing Income

Contractual 3% annual rent increases provide consistent cash flow growth and inflation protection.



Favorable Lease Structure

Triple Net



Reduced Landlord Risk

 **OneOncology**™ lease guarantee



Long-Term Income Security

Lease term extends through January 2031, ensuring predictable revenue.



Attractive Pricing Basis

Enhanced yield and comparative market positioning.

Rent Schedule

RENT INCREASE DATE	MONTHLY RENT	ANNUAL RENT	RENT PSF
2/1/2026	\$17,835.19	\$214,022.25	\$19.50
2/1/2027	\$18,374.82	\$220,497.80	\$20.09
2/1/2028	\$18,923.59	\$227,083.10	\$20.69
2/1/2029	\$19,490.66	\$233,887.90	\$21.31
2/1/2030	\$20,076.02	\$240,912.23	\$21.95





ONEONCOLOGY, LLC



OneOncology, LLC is a leading Physician-Led Management Services Organization (MSO) that empowers independent community oncology practices through shared infrastructure and capital. OneOncology's strength in the Midwest is primarily concentrated in Michigan, where it has established a dominant position by partnering with the state's largest physician-owned oncology practices. The cornerstone of OneOncology's Midwest presence is its partnership with Cancer & Hematology Centers (CHC), the largest physician-owned oncology and hematology practice in Michigan.

Parent Company: Cencora

OneOncology was acquired by Cencora, a publicly traded company, around the same time that OneOncology acquired Compass Cancer & Hematology Centers. As a result of this transition, OneOncology now operates as a subsidiary within a public company structure. Due to this ownership change, standalone OneOncology financial statements are classified as material non-public information and are not permitted to be disclosed under SEC regulations. However, prospective parties may reference Cencora's publicly available financial disclosures, including its Form 10-Q filings, for insight into the broader parent company's financial position. OneOncology is available to discuss the business and its financial profile at a high level and can facilitate direct conversations with qualified parties as needed.

OneOncology is currently transitioning to full ownership by Cencora (formerly AmerisourceBergen), a Fortune 50 pharmaceutical sourcing and distribution leader.

- **Ownership Transition:** In December 2025, Cencora announced it would accelerate its acquisition of the majority interest it did not already own from TPG and other shareholders for approximately \$3.6 billion.
- **Strategic Goal:** The deal, which values OneOncology at an enterprise value of \$7.4 billion, integrates OneOncology into Cencora's broader specialty services and MSO solutions.

Financial Strength: OneOncology's financial profile has seen rapid appreciation and significant capital backing:

- **Valuation Growth:** The company's enterprise value jumped from \$2.1 billion in April 2023 to \$7.4 billion by December 2025.
- **Capital Investment:** The parent company, Cencora, is an investment-grade entity with over \$1 billion committed through 2030 to expand its distribution networks.
- **Revenue Support:** OneOncology invests heavily in its partners, having committed over \$70 million in 2023 and an additional \$58.5 million in 2024 to fund service line expansions like radiation therapy, imaging, and lab services.

➤ ONEONCOLOGY, LLC

Tenant Analysis:

As an MSO, OneOncology's "tenants" are its affiliated independent practices, which rely on the platform for operational stability and growth.

- **Patient Volume:** These practices collectively care for approximately 1 million patients annually, providing a stable and massive recurring revenue base.
- **Ancillary Expansion:** OneOncology has diversified beyond medical oncology into urology with the acquisition of United Urology Group (250+ providers), creating cross-specialty synergies.

Operational Strength

OneOncology leverages the Midwest as a key site for its most advanced clinical and real estate initiatives:

- **Research Leadership:** CHC hosts START-Midwest, one of the largest Phase I clinical trial units in the Midwestern U.S., with approximately 60 open trials.
- **Real Estate Investment:** In February 2026, Montecito Medical acquired a five-building portfolio in Grand Rapids, Big Rapids, and Holland, totaling 152,000 square feet, specifically to support OneOncology's long-term operations in the "Upper Midwest".

Company Type

Public (Cencora)

Headquarters

Nashville, Tennessee

Year in Business

2018

Website

www.oneoncology.com

Parcel

SITE:
Condo Unit
(Unit 2)



Retailer



- Eastwood Towne Center**
- lululemon
 - WILLIAMS SONOMA
 - TALBOTS
 - PRYDEBANK
 - BANANA REPUBLIC
 - JCREW
 - JO'S A BANK
 - VICTORIA'S SECRET
 - URBAN OUTFITTERS
 - PF CHANG'S
 - KAY JEWELLERS
 - Buckle
 - GameStop
 - LOFT
 - EXPRESS
 - TORRID

OneOncology

THE CANCER & HEMATOLOGY CENTERS





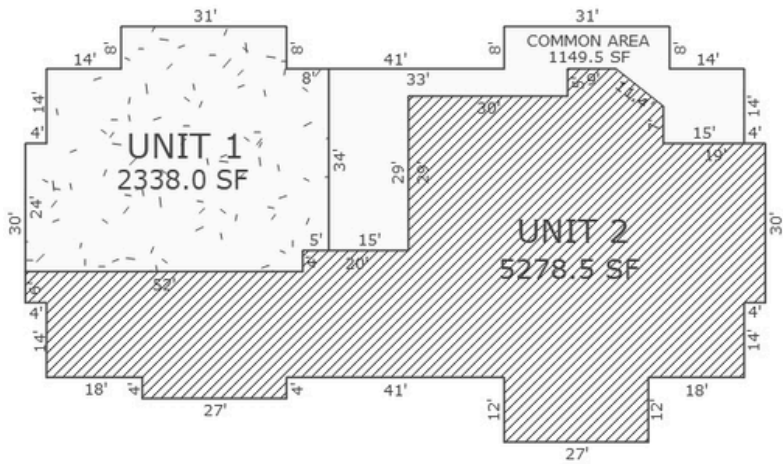

LOWER LEVEL
 8766.0 SF

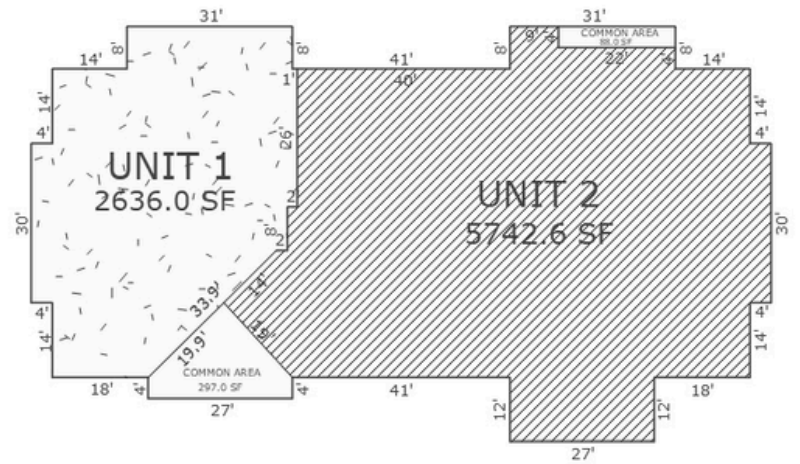

UPPER LEVEL
 8766.0 SF

East Lansing, Michigan

East Lansing, MI is strategically positioned in central Michigan, directly adjacent to the state capital of Lansing. The city benefits from excellent regional accessibility via major transportation corridors including US-127 and I-496, providing convenient connectivity to Detroit, Grand Rapids, and surrounding Midwestern markets. Its location within the Lansing - East Lansing metropolitan area supports efficient commuting patterns and easy access to business, education, and government hubs. East Lansing has a 2026 population of 49,435.

The local economy is anchored by Michigan State University, one of the largest and most prominent public research universities in the United States. The university significantly contributes to employment stability, innovation, and consistent population inflows. In addition to higher education, the regional economy is supported by government, healthcare, technology, and research sectors, creating a diverse and resilient economic base with steady demand drivers.

East Lansing offers a vibrant mix of cultural, educational, and recreational attractions. Michigan State University serves as the community's focal point, bringing athletic events, academic activity, arts, and year-round visitor traffic. The city features a lively downtown district with dining, retail, and entertainment options, while nearby Lansing provides additional amenities including government institutions, museums, and performing arts venues. Together, these factors create a dynamic environment attractive to residents, students, and professionals alike.



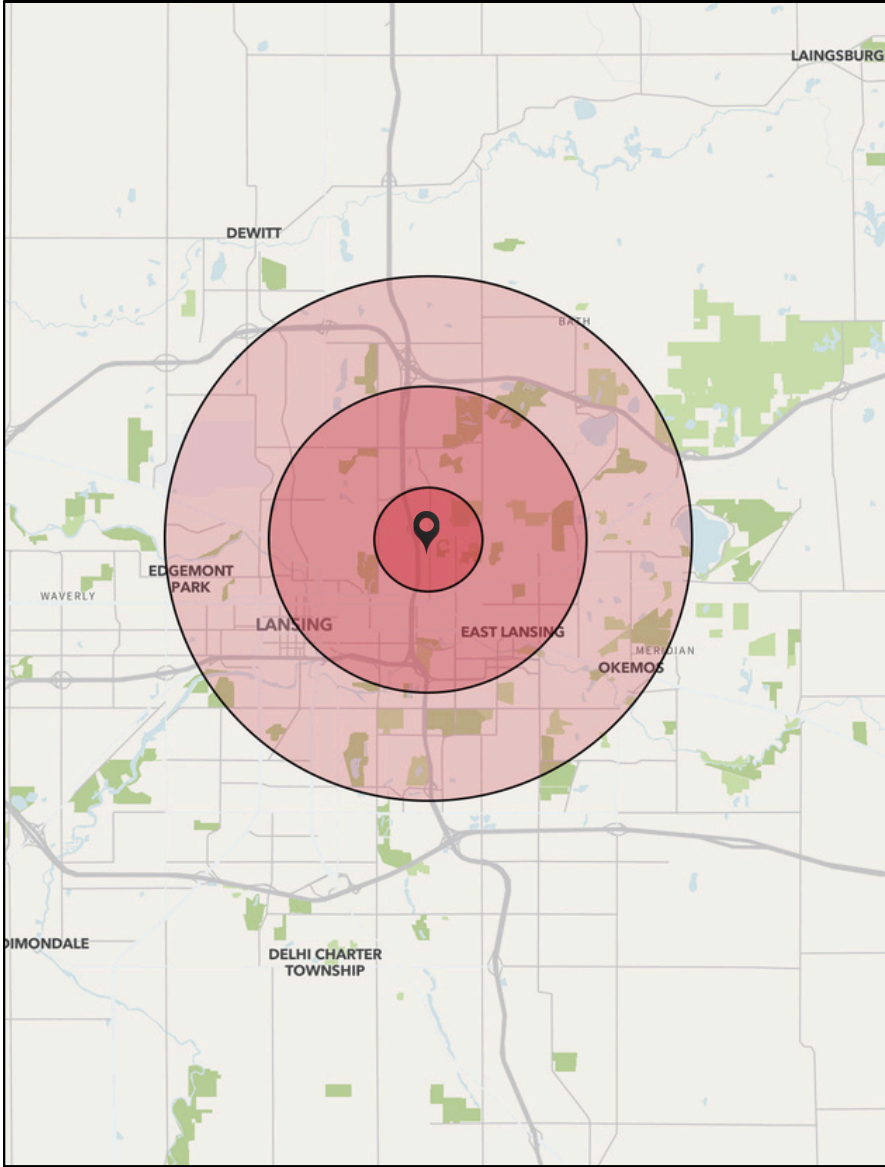

1625 Ramblewood Dr, Unit 2 | East Lansing, MI 48823

	1 Mile	3 Mile	5 Mile
Total Population	9,687	87,132	162,275
Average Age	40	34	36
Total Households	4,664	34,224	67,056
Average HH Income	\$94,921	\$76,357	\$78,998
Average HH Value	\$235,684	\$213,984	\$207,871



517-281-5800



jabood@naimidmichigan.com



naimidmichigan.com

JEROME ABOOD

Background & Experience

With over 35 years of experience in real estate, Jerome blends deep industry knowledge with a passion that began on the golf course. As a competitive golfer in his youth, he forged early connections with top developers—an experience that inspired him to earn his real estate license at just 18. Jerome holds a Bachelor's degree in Business and Finance from Michigan State University and a Juris Doctor from Cooley Law School. While pursuing his education, he began investing in student housing near MSU, eventually expanding into commercial real estate and development. His portfolio includes build-to-suit projects for national retailers, as well as multifamily developments, retail centers, and vacant land acquisitions. Jerome's hands-on experience as both investor and advisor gives him a unique perspective on every deal, ensuring his clients benefit from well-rounded, strategic guidance.

Professional Associations & Designations

- CCIM: Certified Commercial Investment Member
- MAR: Michigan Association of REALTORS®
- NAR: National Association of REALTORS®
- CBOR: Commercial Board of REALTORS®



2149 Jolly Rd. Suite 200, Okemos, MI 48840

517 - 487 - 9222

www.naimidmichigan.com