



FOR LEASE | QUONSET BUILDING AND YARD AREA



335 36 Avenue NE

Calgary, Alberta

AVAILABLE: August 1, 2026

Standalone Quonset building with fenced yard space.

Municipal Address

335 36 Avenue NE
Calgary, Alberta

Legal Description

Plan 5942AD, Block 15 Lot 33-44

Zoning

I-R Industrial - Redevelopment

Area

4,773 sq. ft.—Quonset building
~0.44 acres—lot

Operating Costs

\$4.80 / sq. ft. (2026 CAM & Tax)

Loading & Access

At Grade 20'2"W x 14'5"H

Building Dimensions

95' 1" x 48' 9"
29.0m x 14.9m

Lot Dimensions

115' x 166'
35.1m x 50.7m

The information contained herein may change and the property removed from the market at any time without prior notice. It has been obtained from sources believed to be correct but does not form part of any present or future contract.



335 36 Avenue NE

AVAILABLE: August 1, 2026

Calgary, Alberta

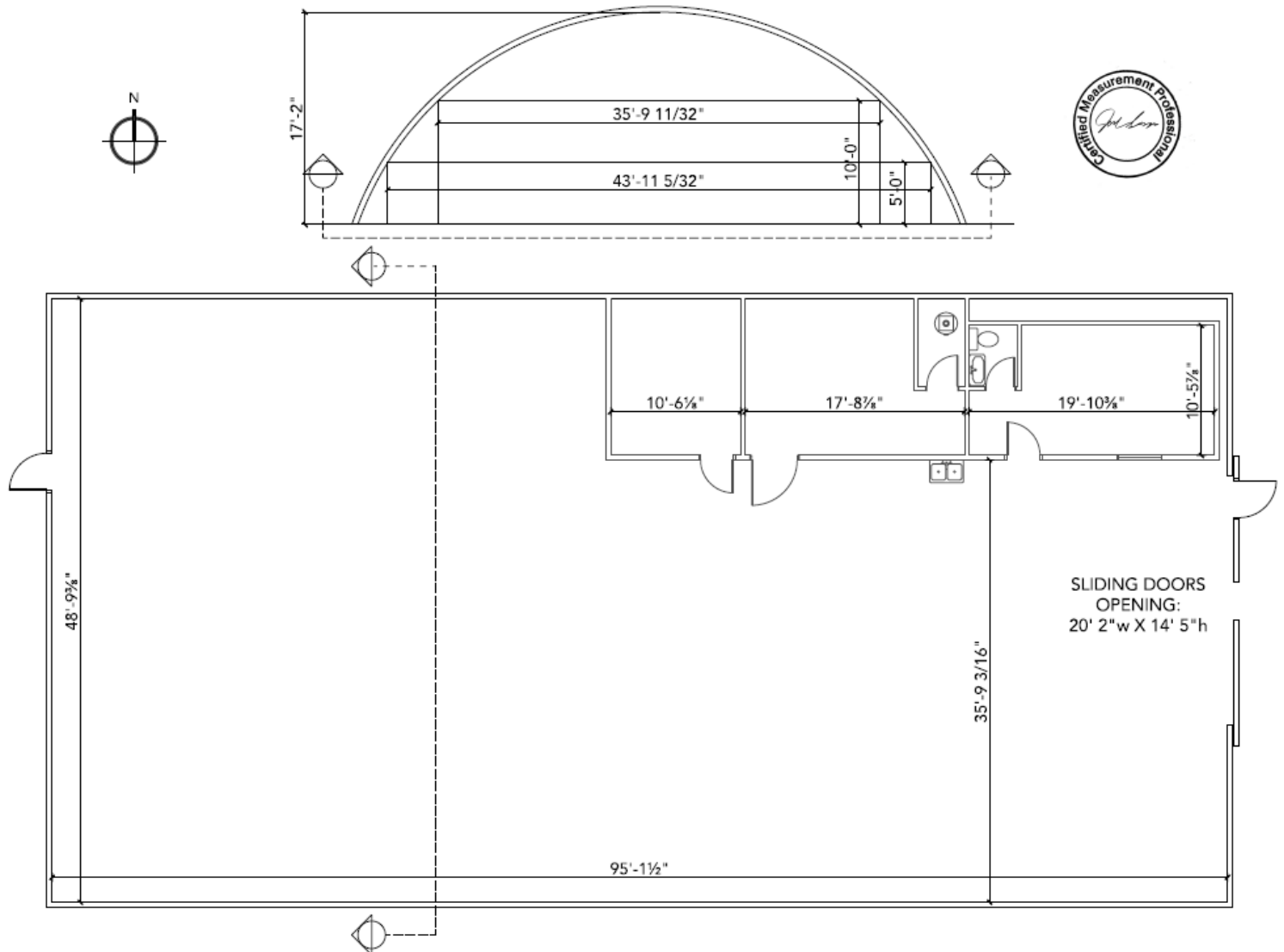

The information contained herein may change and the property removed from the market at any time without prior notice. It has been obtained from sources believed to be correct but does not form part of any present or future contract.



Kennington Properties Ltd.

#140, 5050 106 Avenue SE, Calgary, AB, T2P 2K9

Phone: 403-215-0380

leasing@kennington.ca

335 36 Avenue NE

Calgary, Alberta

AVAILABLE: August 1, 2026



The information contained herein may change and the property removed from the market at any time without prior notice.
It has been obtained from sources believed to be correct but does not form part of any present or future contract.



335 36 Avenue NE

AVAILABLE: August 1, 2026

Calgary, Alberta

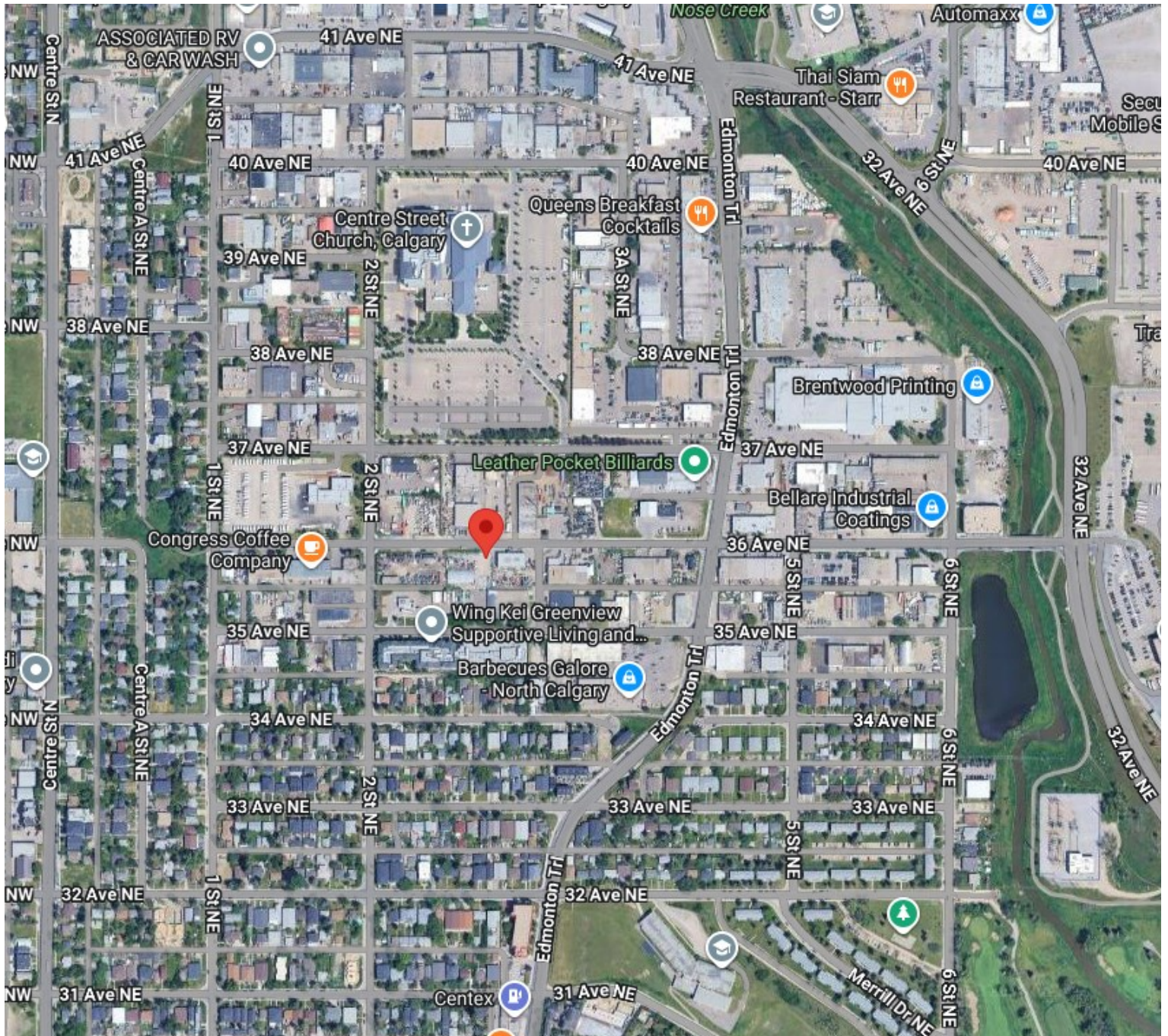

The information contained herein may change and the property removed from the market at any time without prior notice. It has been obtained from sources believed to be correct but does not form part of any present or future contract.