

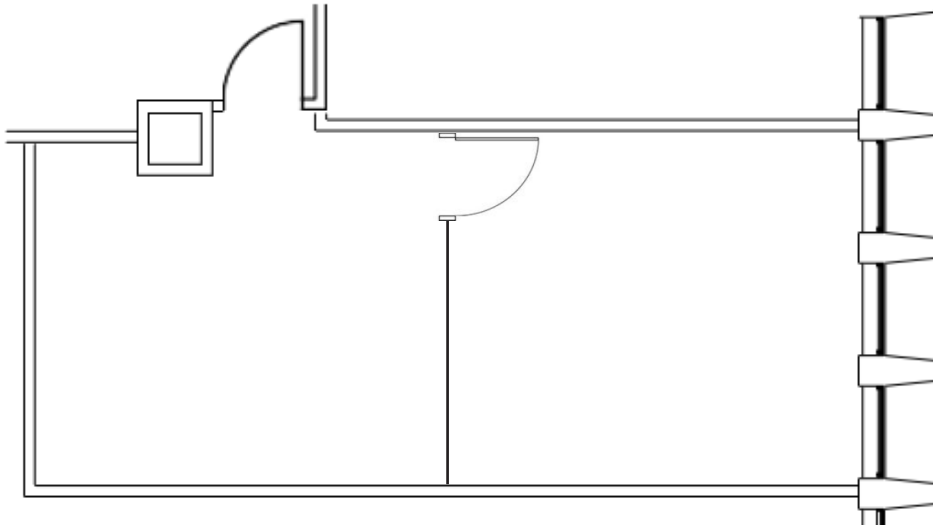

FLOOR PLAN



LEASE INFORMATION

Building	Lloyd 700 Building
Address	700 NE Multnomah St
Floor	Third
Suite	355
Total SF	570 RSF

JEFF FALCONER, SIOR

503-542-4346

jeff@capacitycommercial.com

MCCOY DOERRIE, SIOR

503-523-7751

mccoy@capacitycommercial.com