

FOR LEASE

SOUTH PARK BUSINESS CENTER

8600 COMMODITY CIRCLE | ORLANDO, FL 32819



FLEX/OFFICE/WAREHOUSE AVAILABLE

PROPERTY OVERVIEW

TOTAL SIZE:	134,967 SF
AVAILABLE	1,830 - 2,240 SF
CLEAR HEIGHT:	18' (less sprinklers)
ZONING:	I-2/I-3 - Industrial District
POWER:	3-Phase, 120/208 V, 150 Amp

LOCATION

Strategically located in the South Orlando submarket, offering immediate access to Orlando's major transportation arteries. The property is just minutes from State Road 528 (Beachline Expressway), providing direct connections to Orlando International Airport and the Port Canaveral corridor. Interstate 4 is nearby, linking the site to Downtown Orlando, Tampa, and the greater Central Florida region. Florida's Turnpike and State Road 417 (Central Florida Greenway) are also easily accessible, facilitating efficient regional distribution and commuter convenience. This prime location within South Park ensures excellent connectivity to both local and statewide business hubs.

CONTACT:

Ryan Griffith
Senior Vice President/Principal
rgriffith@lee-associates.com
M 908.208.4774

Charles W. Duvall
Senior Associate
cduvall@lee-associates.com
D 321.243.0857

Brady Benton
Associate
bbenton@lee-associates.com
D 863.624.1936

PROXIMITY MAP | 8600 Commodity Circle | Orlando, FL 32819

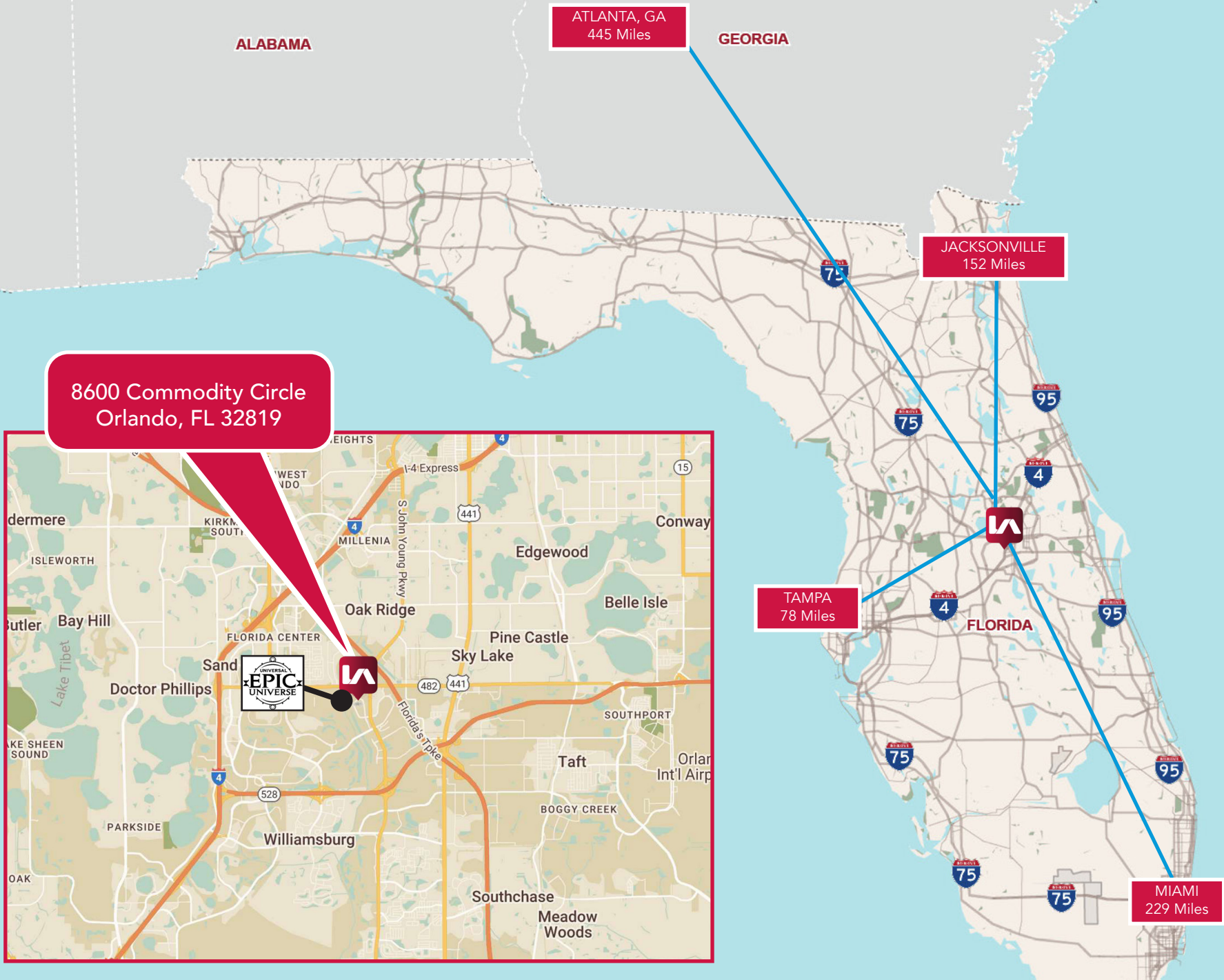

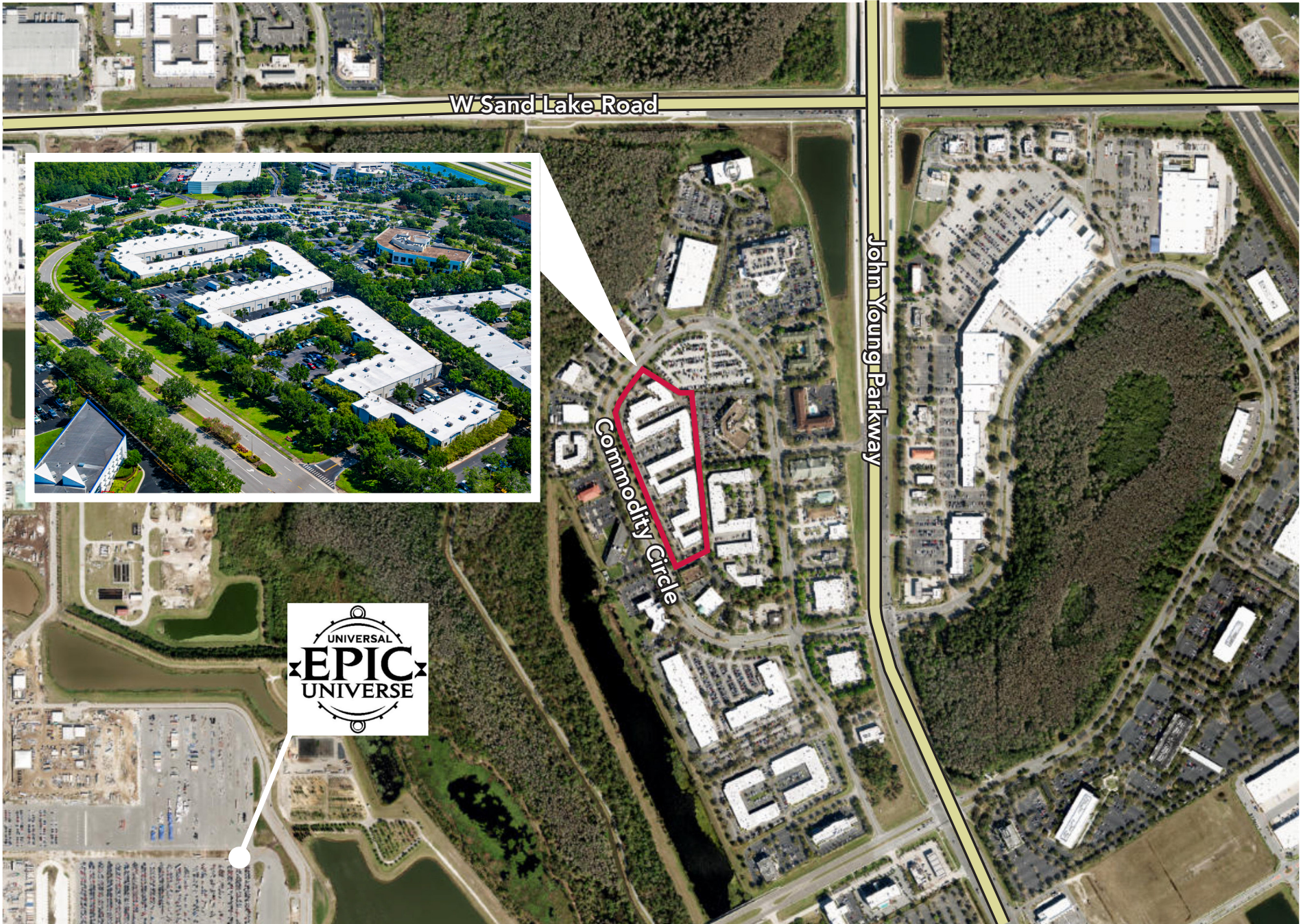

SUITE 132

- SIZE:** 1,830 SF
- OFFICE:** 486 SF
- MEZZANINE:** 330 SF
- WAREHOUSE:** 1,014 SF
- DOORS:** 1 Grade Level Door (10' x 10')
- BASE RENT:** \$3,355.00/MO + Opex

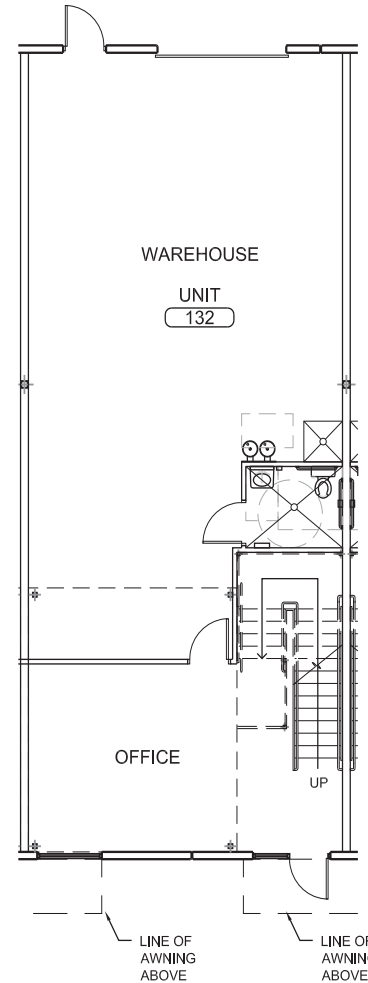

01 Unit 132 - First Floor Plan
SCALE: 3/32" = 1'-0"

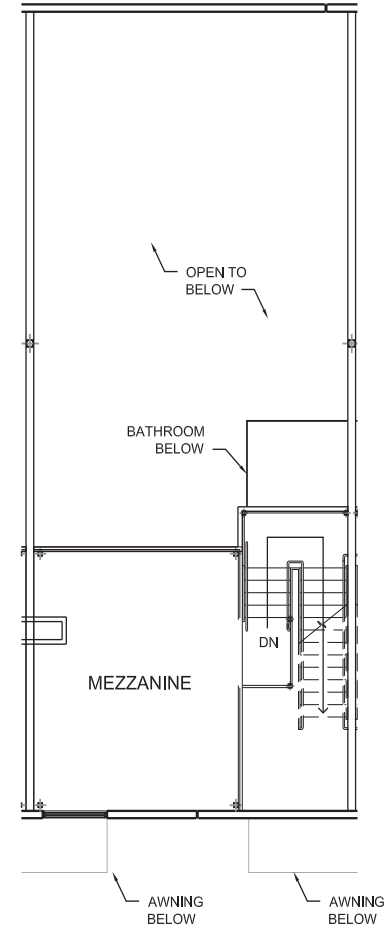

02 Unit 132 - Mezzanine Plan
SCALE: 3/32" = 1'-0"

All information furnished regarding property for sale, rental or financing is from sources deemed reliable, but no warranty or representation is made to the accuracy thereof and same is submitted to errors, omissions, change of price, rental or other conditions prior to sale, lease or financing or withdrawal without notice. No liability of any kind is to be imposed on the broker herein.

SUITE 134

- SIZE:** 1,830 SF
- OFFICE:** 486 SF
- MEZZANINE:** 330 SF
- WAREHOUSE:** 1,014 SF
- DOORS:** 1 Grade Level Door (10' x 10')
- BASE RENT:** \$3,355.00/MO + Opex

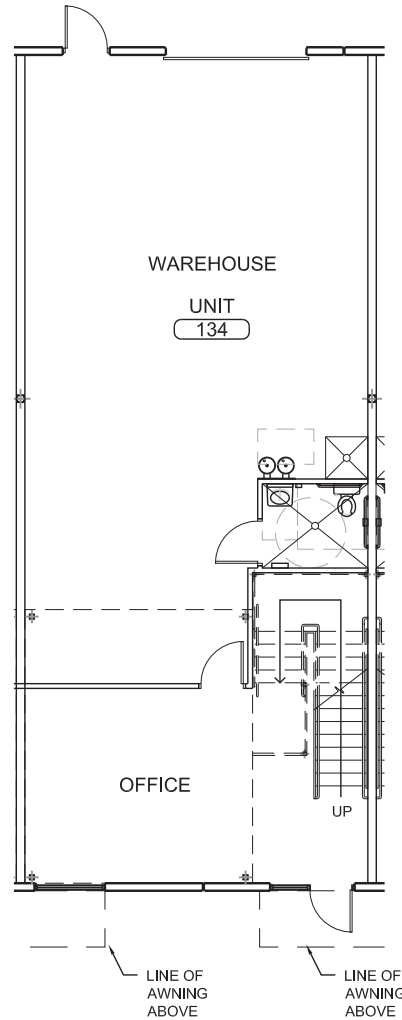

01 Unit 134 - First Floor Plan
SCALE: 3/32" = 1'-0"

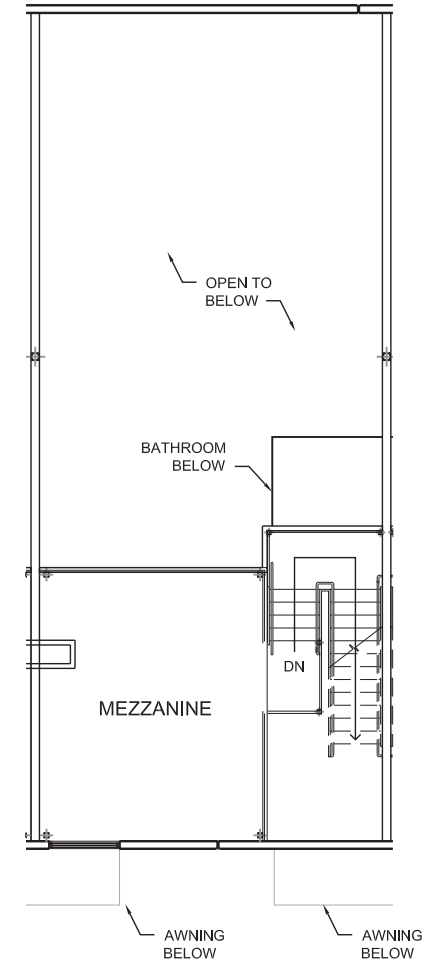

02 Unit 134 - Mezzanine Plan
SCALE: 3/32" = 1'-0"

All information furnished regarding property for sale, rental or financing is from sources deemed reliable, but no warranty or representation is made to the accuracy thereof and same is submitted to errors, omissions, change of price, rental or other conditions prior to sale, lease or financing or withdrawal without notice. No liability of any kind is to be imposed on the broker herein.

SUITE 142

SIZE: 2,240 SF
OFFICE: 679 SF
MEZZANINE: 357 SF
WAREHOUSE: 1,203 SF
DOORS: 1 Grade Level Door (10' x 10')
BASE RENT: \$4,106.67/MO + Opex

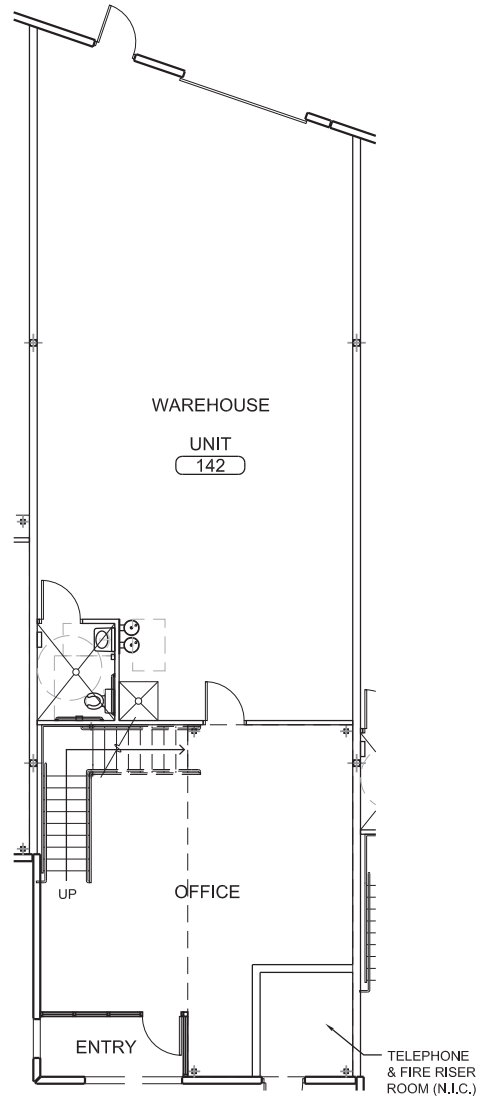

01 Unit 142 - First Floor Plan
SCALE: 3/32" = 1'-0"

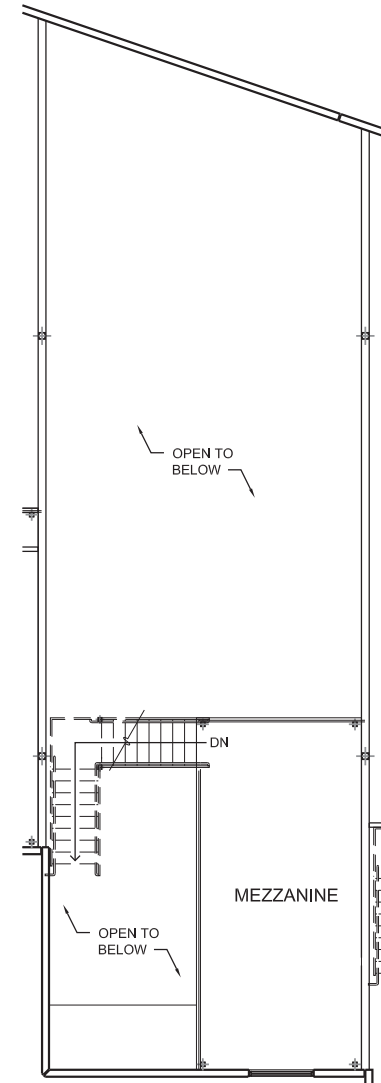

02 Unit 142 - Mezzanine Plan
SCALE: 3/32" = 1'-0"

All information furnished regarding property for sale, rental or financing is from sources deemed reliable, but no warranty or representation is made to the accuracy thereof and same is submitted to errors, omissions, change of price, rental or other conditions prior to sale, lease or financing or withdrawal without notice. No liability of any kind is to be imposed on the broker herein.

SUITE 150

SIZE: 1,830 SF

OFFICE: 486 SF

MEZZANINE: 330 SF

WAREHOUSE: 1,014 SF

DOORS: 1 Grade Level Door (10' x 10')

BASE RENT: \$3,355.00/MO + Opex

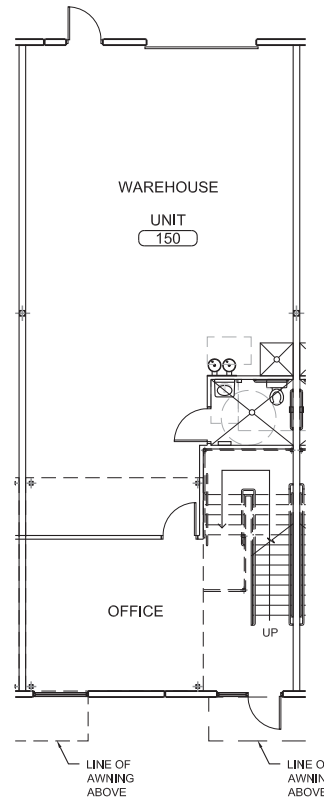

01 Unit 150 - First Floor Plan
SCALE: 3/32" = 1'-0"

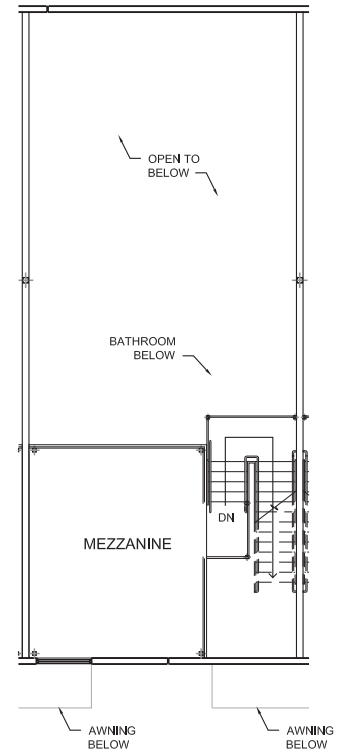

02 Unit 150 - Mezzanine Plan
SCALE: 3/32" = 1'-0"



All information furnished regarding property for sale, rental or financing is from sources deemed reliable, but no warranty or representation is made to the accuracy thereof and same is submitted to errors, omissions, change of price, rental or other conditions prior to sale, lease or financing or withdrawal without notice. No liability of any kind is to be imposed on the broker herein.