

1001 - 1023 STANYAN STREET  
 REVISED COMMERCIAL SPACES

PROJECT NUMBER	2012.01
SCALE	3/16" = 1'-0"
DATE	2021-08-27

SK-6

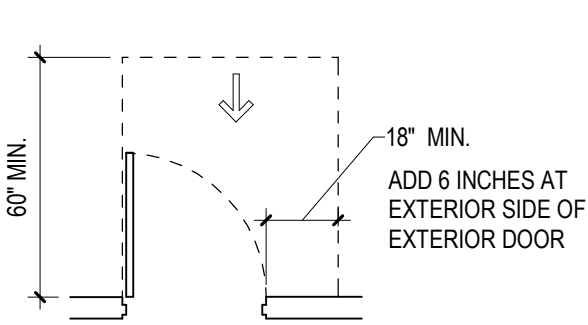

(A) FRONT APPROACH, PULL SIDE

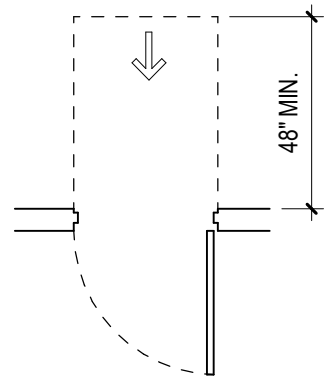

(B) FRONT APPROACH, PUSH SIDE

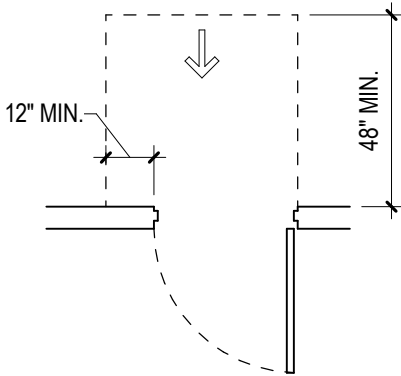

(C) FRONT APPROACH, PUSH SIDE, DOOR PROVIDED WITH BOTH CLOSER AND LATCH

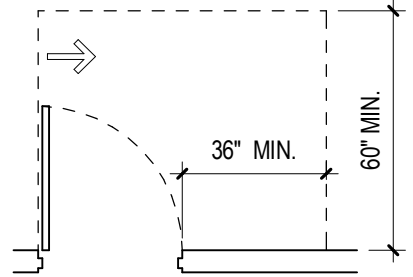

(D) HINGE APPROACH, PULL SIDE

(E) RESERVED

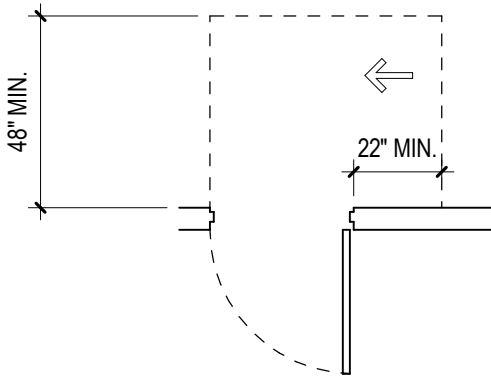

(G) HINGE APPROACH, PUSH SIDE, DOOR PROVIDED WITH BOTH CLOSER AND LATCH

(I) RESERVED

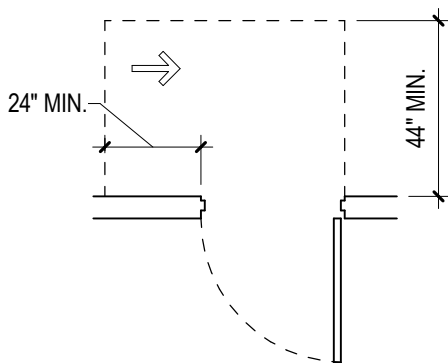

(J) LATCH APPROACH, PUSH SIDE

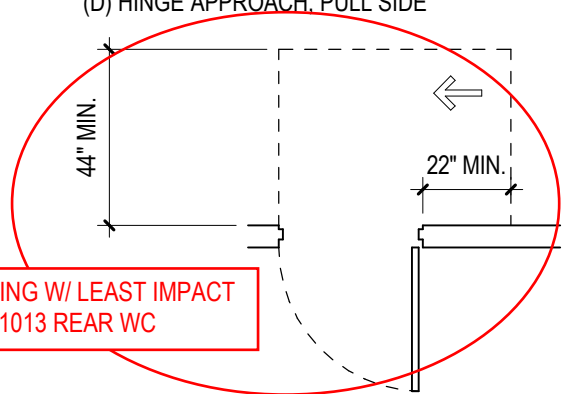

(F) HINGE APPROACH, PUSH SIDE

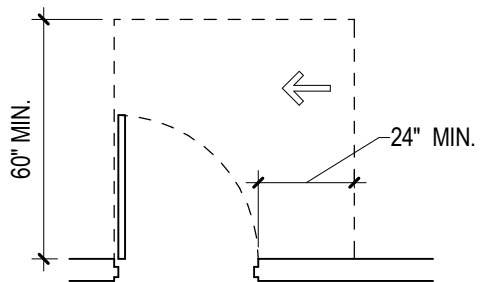

(H) LATCH APPROACH, PULL SIDE

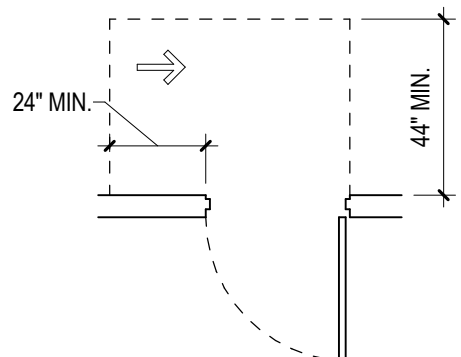

(K) LATCH APPROACH, PUSH SIDE, DOOR PROVIDED WITH CLOSER

1. REFERENCE 2016 CBC FIGURES 11B-404.2.4.1

1/4" = 1'-0"