

1011 E TOUHY AVENUE DES PLAINES



**VARIOUS OFFICE SPACES
AVAILABLE FOR LEASE**

Property Management
Service Provided by:



9450 WEST BRYN MAWR AVENUE | SUITE 550 | ROSEMONT, IL 60018
773.355.3000 (main) | www.lee-associates.com

TONY RUSSO | Senior Vice President
trusso@lee-associates.com | 773.355.5805

All information furnished regarding property for sale, rental or financing is from sources deemed reliable, but no warranty or representation is made to the accuracy thereof and same is submitted to errors, omissions, change of price, rental or other conditions prior to sale, lease or financing or withdrawal without notice. No liability of any kind is to be imposed on the broker herein.



FIVE STORY OFFICE BUILDING OFFERING VIEWS OF CHICAGO O'HARE INTERNATIONAL AIRPORT, LAKE OPEKA & DOWNTOWN CHICAGO



KEY-CARD SYSTEM FOR AFTER HOURS ACCESS FOR TENANTS SAFETY AND CONVENIENCE



FEATURES A THREE-STORY ATRIUM, WATER FEATURE, GRANITE FLOORS, ETCHED GLASS AND MARBLE



FULLY CUSTOMIZABLE OFFICE SPACES



BEAUTIFUL NATURAL LIGHT OFFERS UNENCUMBERED VIEWS IN ALL DIRECTIONS AND THE PERFECT FIRST IMPRESSION



MINUTES FROM I-90 & I-294



FIRST FLOOR INCLUDES A DELI WITH SEATING AREA, FITNESS CENTER COMPLETE WITH CARDIO AND WEIGHT TRAINING EQUIPMENT, DELUXE LOCKER ROOM FACILITIES AND FLAT SCREEN TV'S



REPRESENTING 450,000 SF OF OFFICE SPACE, O'HARE OFFICES PROFESSIONAL, ON-SITE MANAGEMENT TEAM, ANTICIPATES AND ADAPTS TO THE BUSINESS NEEDS OF ITS TENANTS, PROVIDING THOSE WITH AN O'HARE OFFICES ADDRESS THE HIGHEST LEVEL OF SERVICE AND VALUE



LOCATED IN CLOSE PROXIMITY TO NUMEROUS DINING & HOTEL OPTIONS, FASHION OUTLETS OF CHICAGO, RIVERS CASINO, MULTIPLE THEATERS, O'HARE INTERNATIONAL AIRPORT AND MORE!

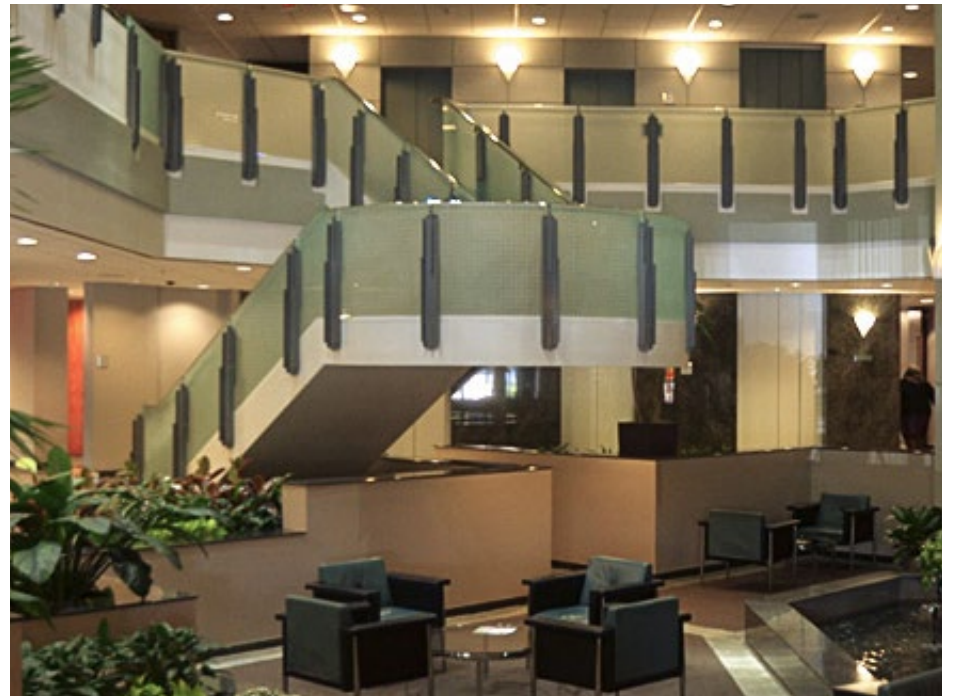

AVAILABLE SUITES

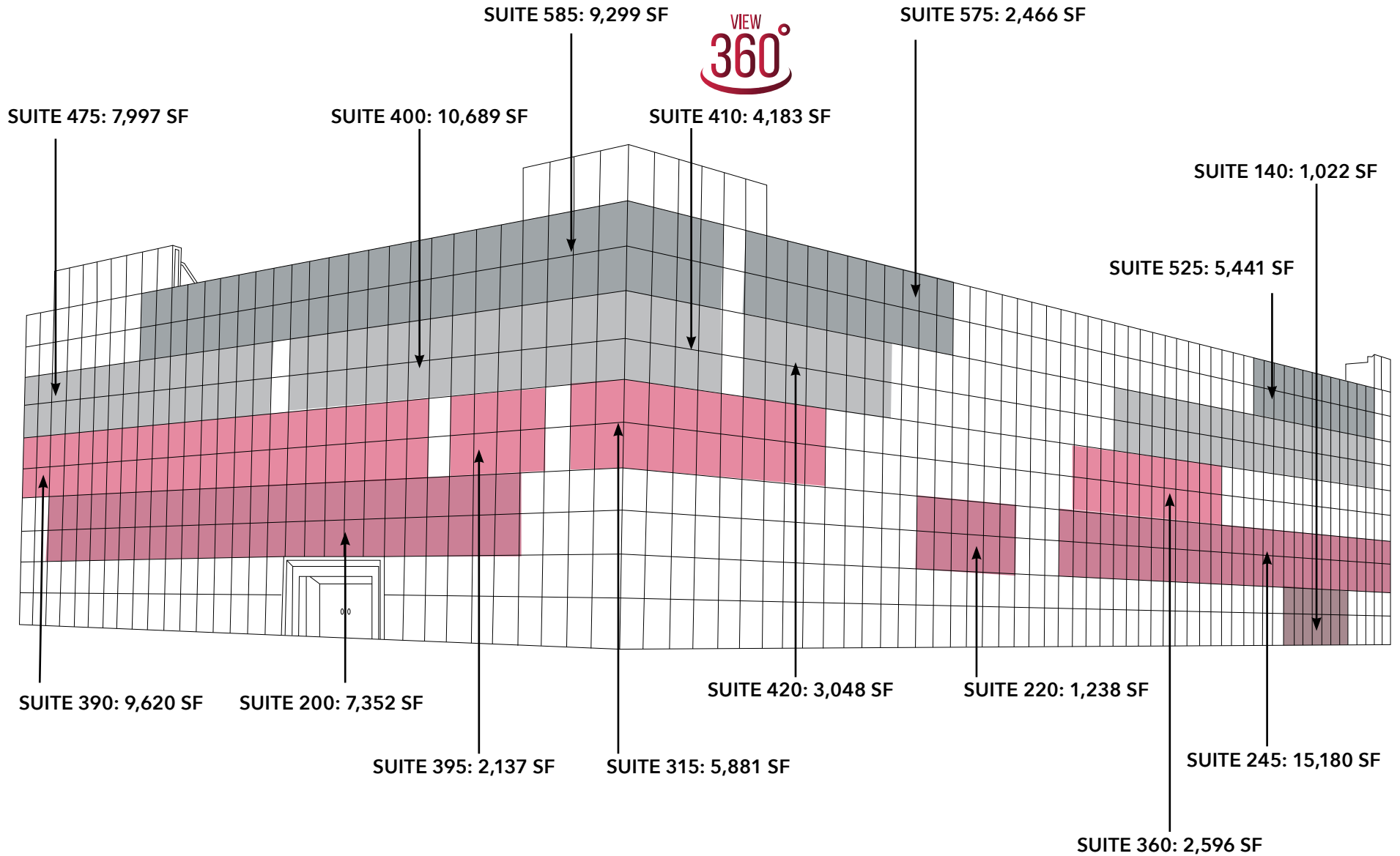

LEASE RATE FOR ALL AVAILABLE SUITES: \$23.50 PSF MG

FIRST FLOOR

SUITE 140

1,022 SF AVAILABLE

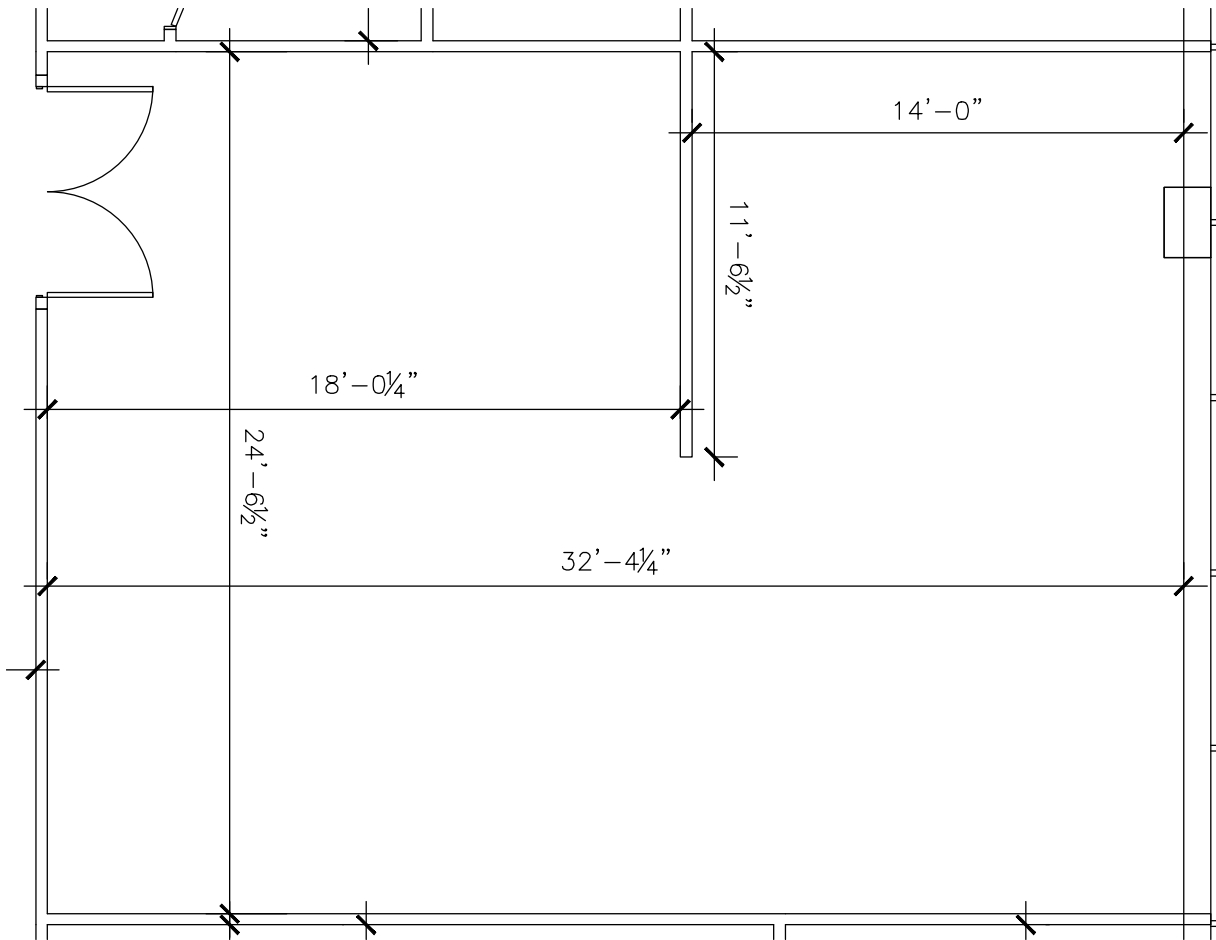

SECOND FLOOR

SUITE 200

7,352 SF AVAILABLE

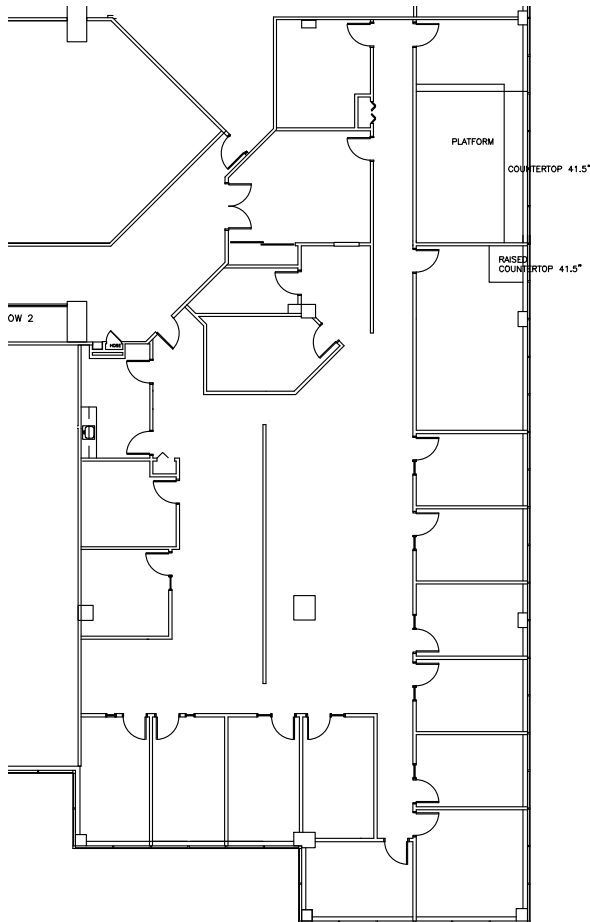

SUITE 220

1,238 SF AVAILABLE

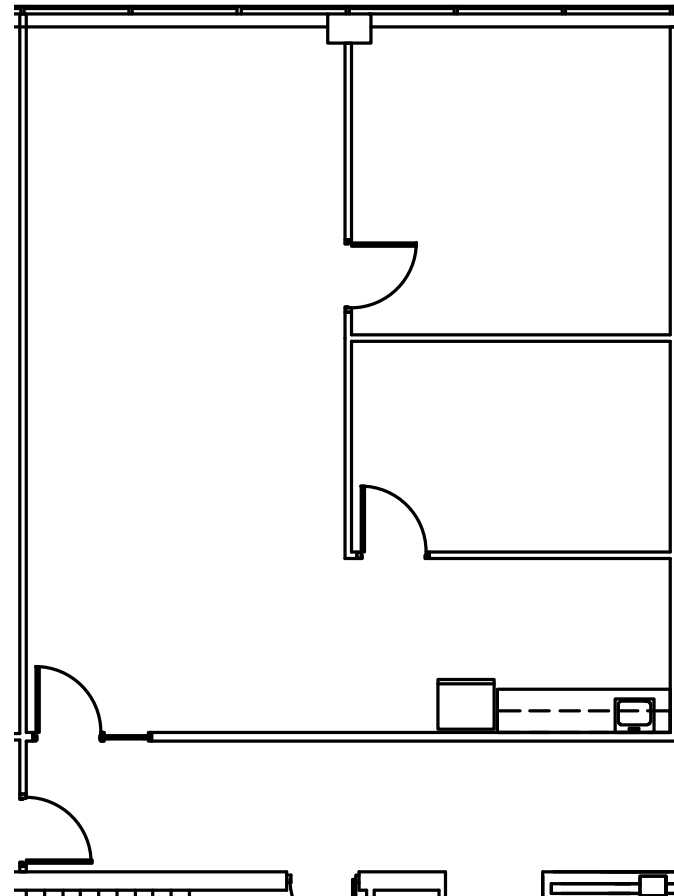

SECOND FLOOR

SUITE 245

15,180 SF AVAILABLE

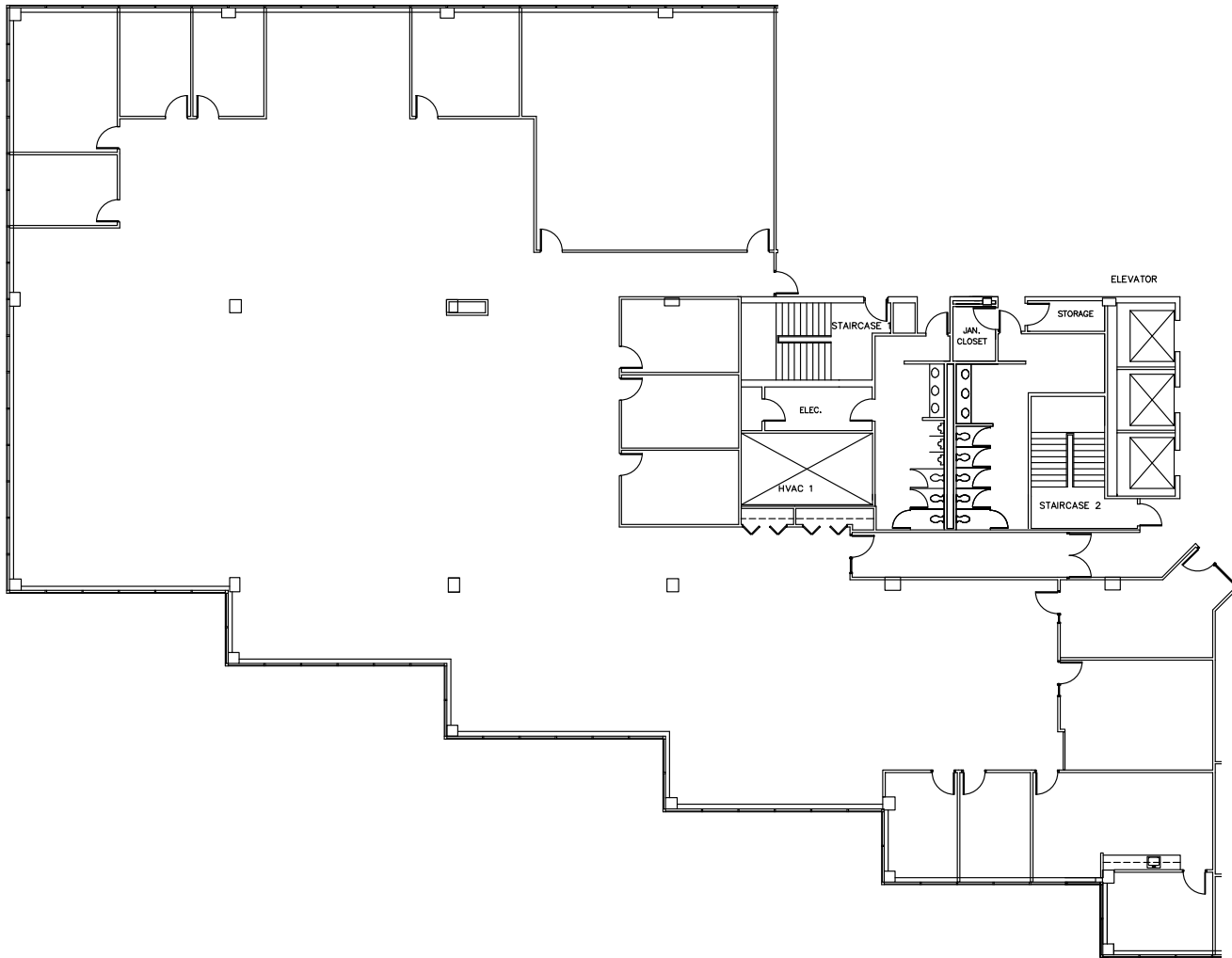

THIRD FLOOR

SUITE 315

5,881 SF AVAILABLE

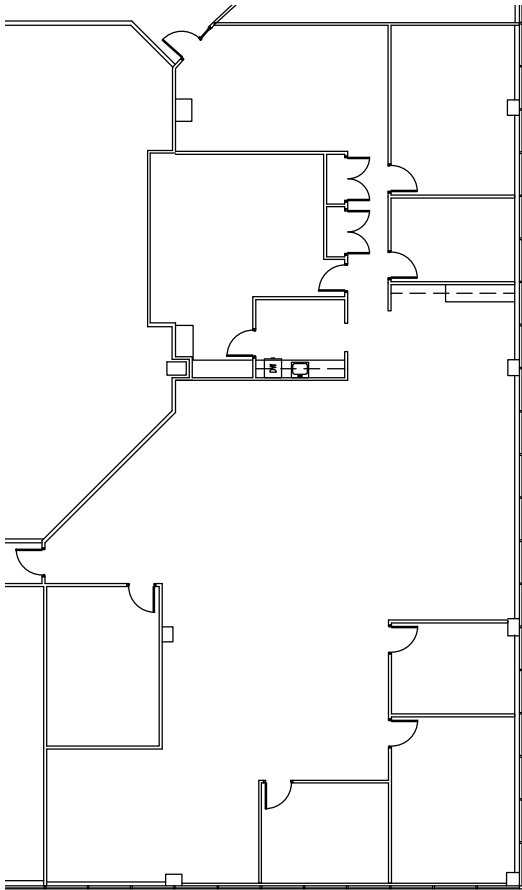

SUITE 360

2,596 SF AVAILABLE

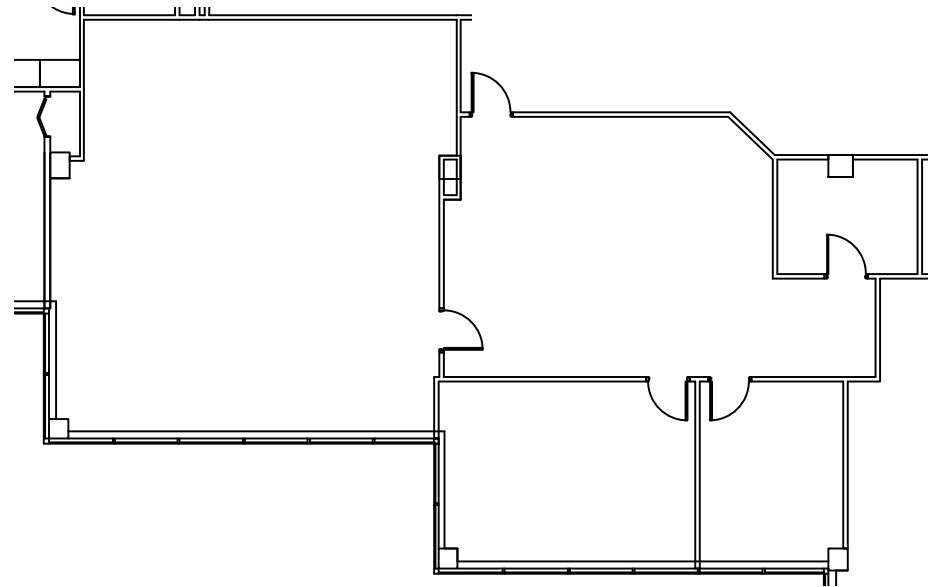

THIRD FLOOR

SUITE 390

9,620 SF AVAILABLE

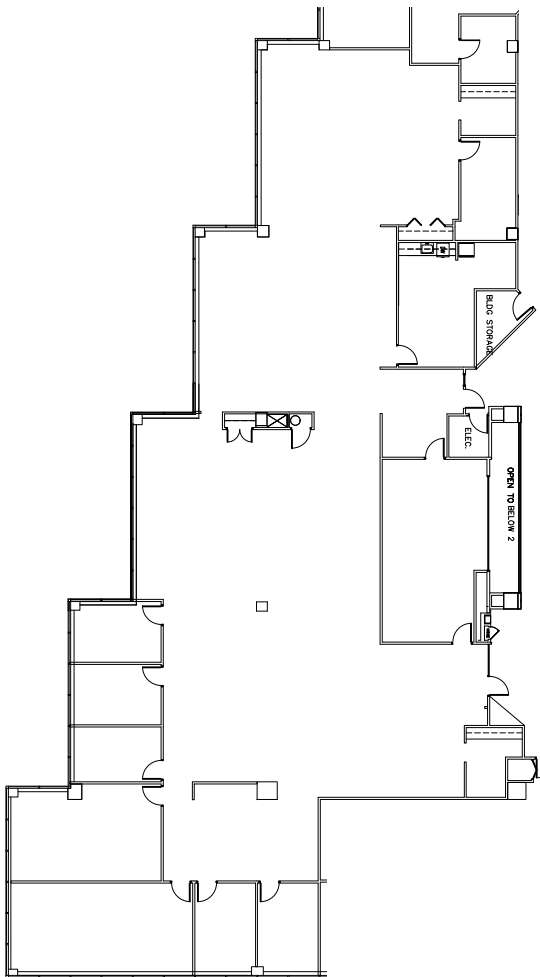

SUITE 395

2,137 SF AVAILABLE

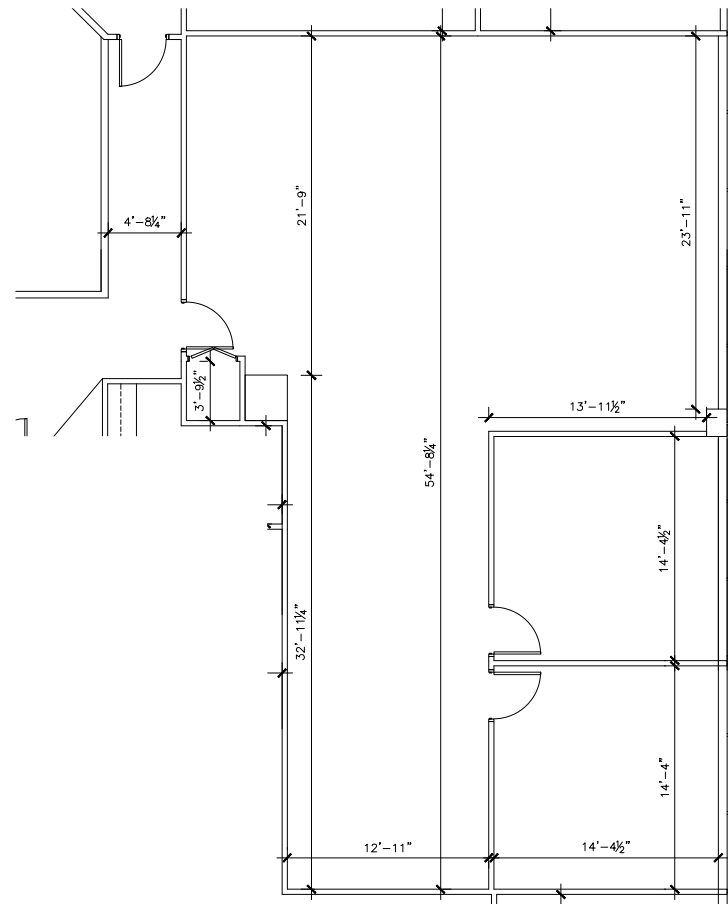

FOURTH FLOOR

SUITE 400

10,689 SF AVAILABLE

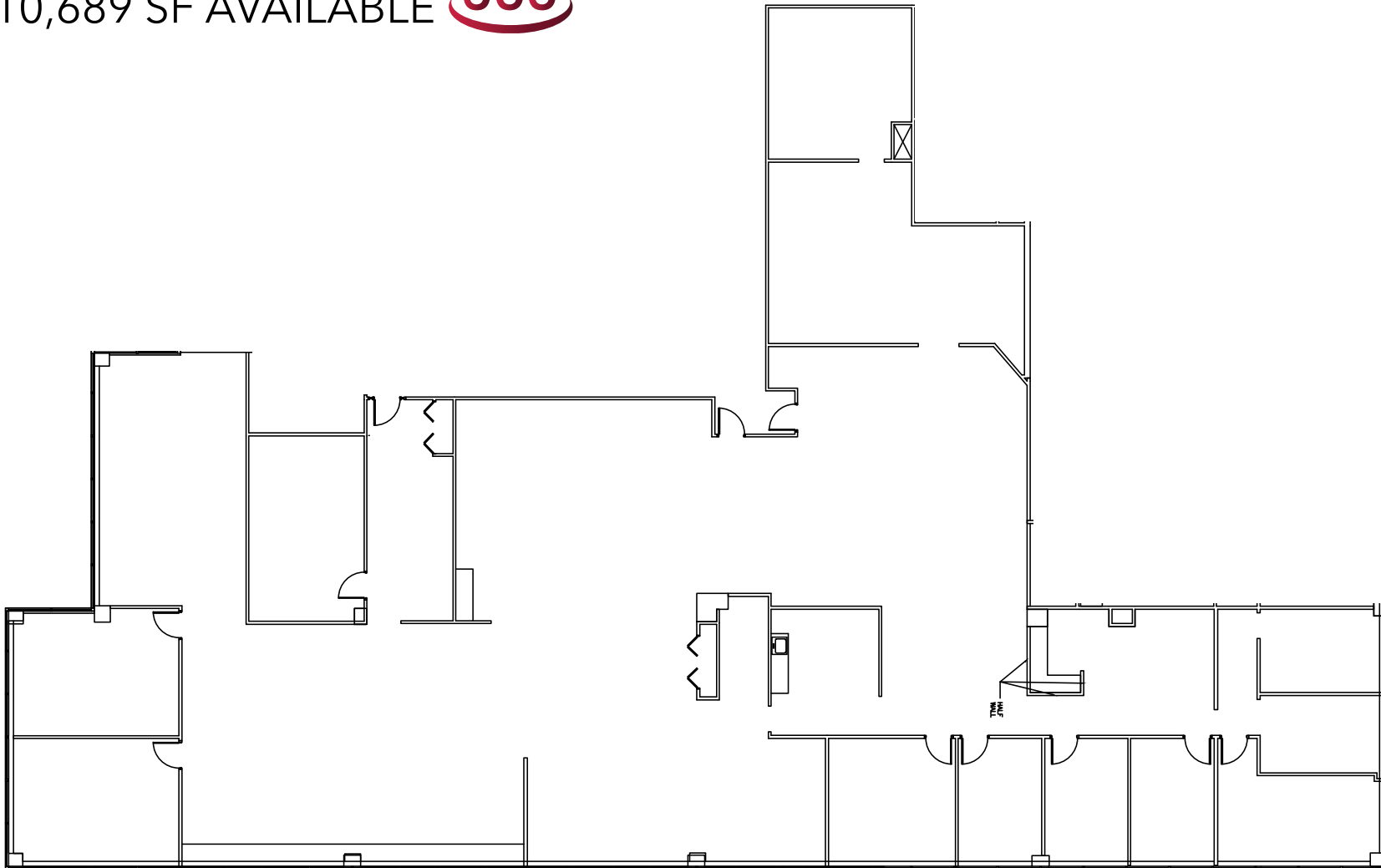

FOURTH FLOOR

SUITE 410

4,183 SF AVAILABLE

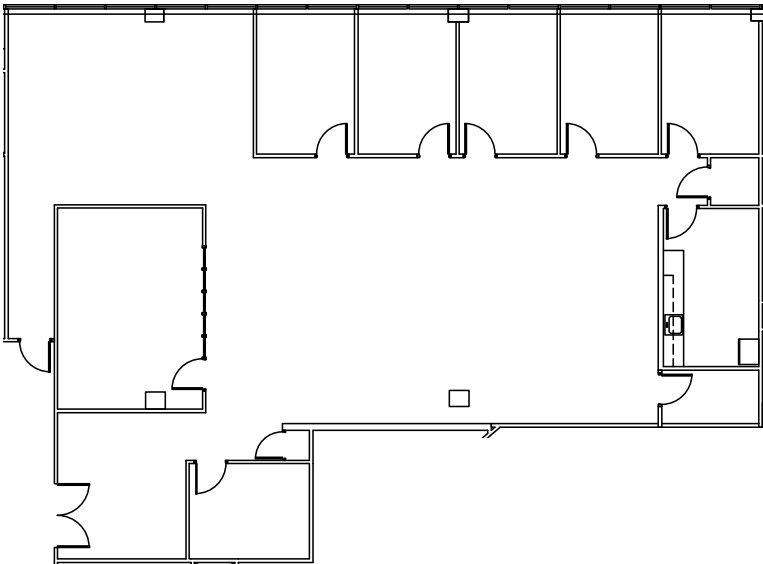

SUITE 420

3,048 SF AVAILABLE

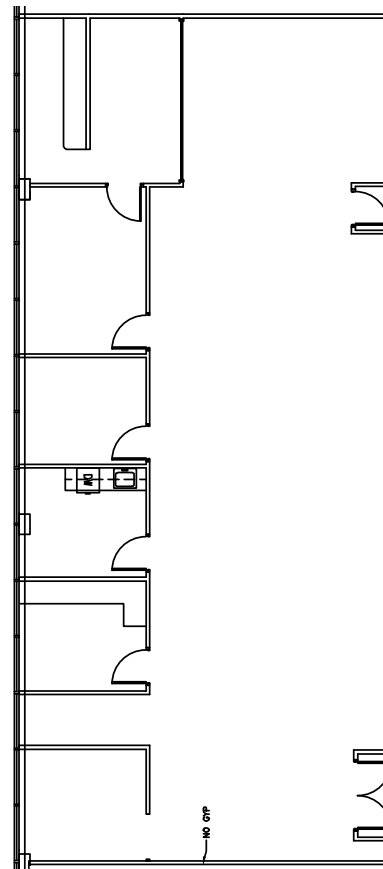

FOURTH FLOOR

SUITE 475

7,997 SF AVAILABLE

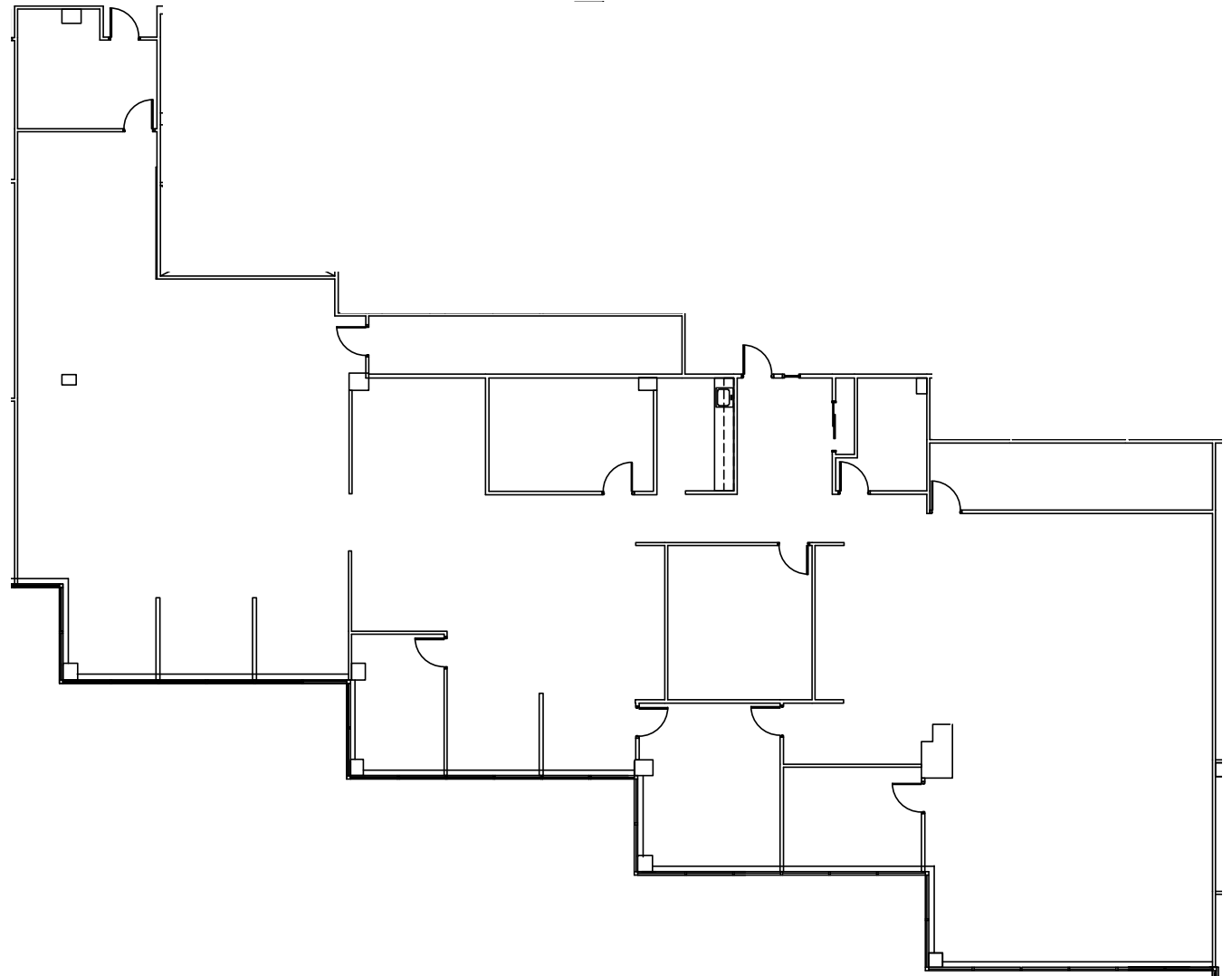

FIFTH FLOOR

SUITE 525

5,441 SF AVAILABLE

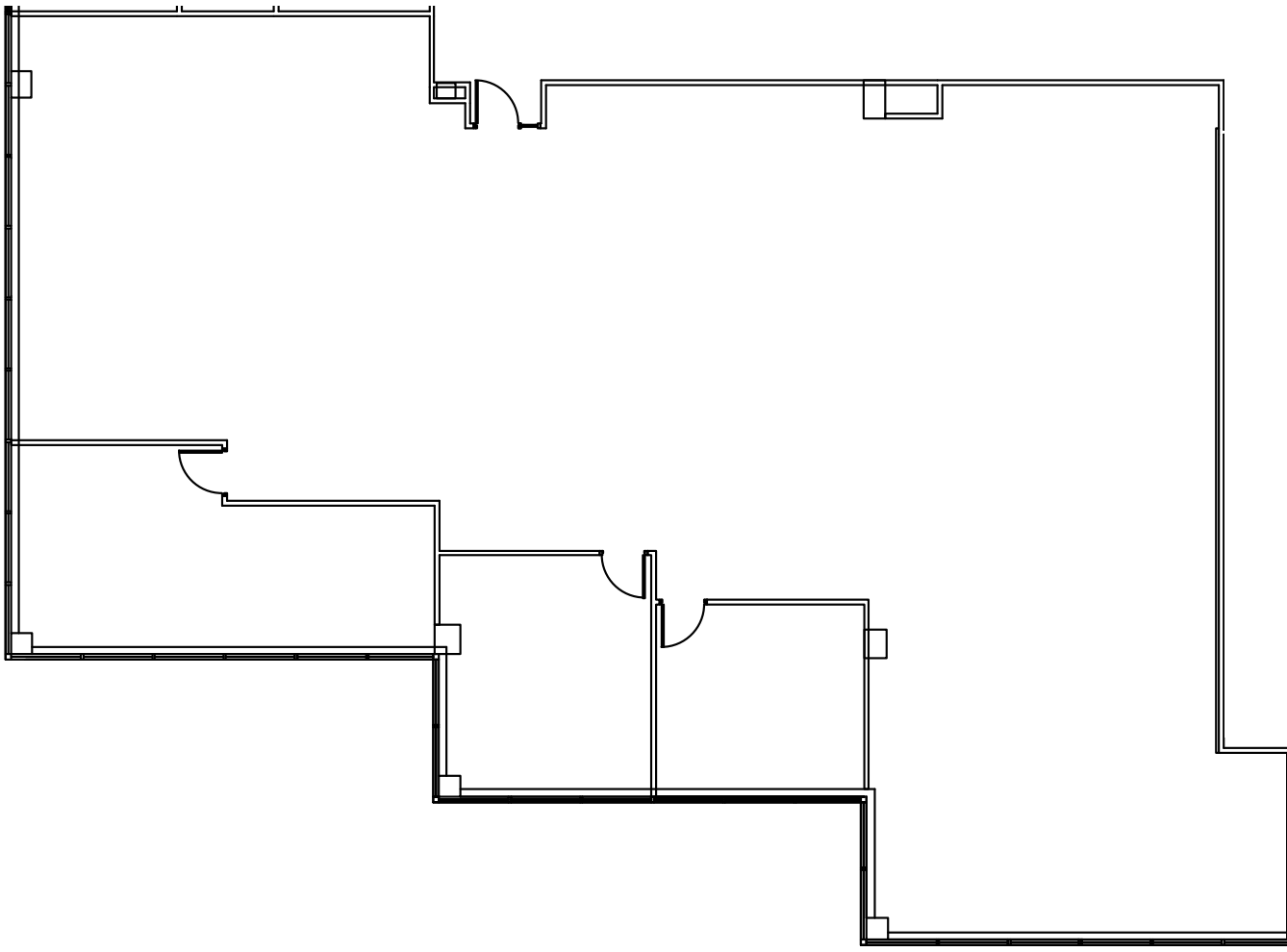

FIFTH FLOOR

SUITE 575

2,466 SF AVAILABLE

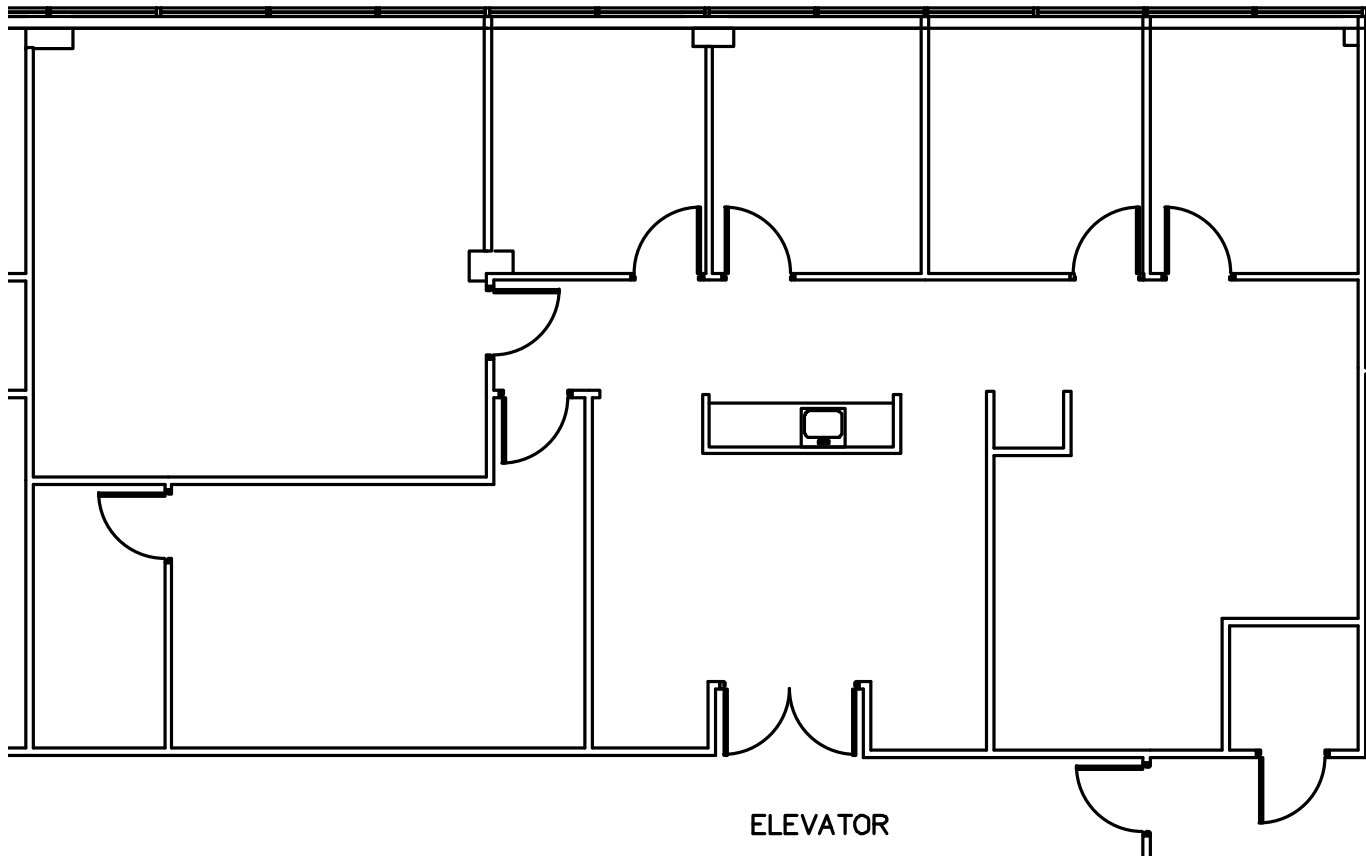

FIFTH FLOOR

SUITE 585

9,299 SF AVAILABLE

