

I-94 DISTRIBUTION CENTER

22000 Industrial Blvd
Rogers, MN 55374



STACK
INDUSTRIAL PARTNERS

PROPERTY OVERVIEW

General Building Information

Year Built
Built 1993 | Expansion in 1998

Construction Type
Concrete Tilt-Up

Zoning
GI (General Industrial)

Building Ownership
Dalfen Industrial

Building Specifications

Total Square Footage
297,256 SF

Parcel Size
16.17 acres

Clear Height
24'

Bay Size
+/- 11,000 SF

Bay Depth
265'

Column Spacing
42' 6" x 38' 6"

Truck Court
120'

Parking Ratio
130 stalls (.44 stalls / 1,000 SF)

Roof Type | Age
Rubber Membrane | 2015

Sprinkler System
ESFR

Utilities

Cable & Internet Provider
Comcast

Power Provider
Xcel Energy

Gas Provider
CenterPoint Energy

Water/Sewer
City of Rogers

Financials

Lease Rate
Negotiable

2026 CAM & TAX
\$3.93/SF

SITE PLAN

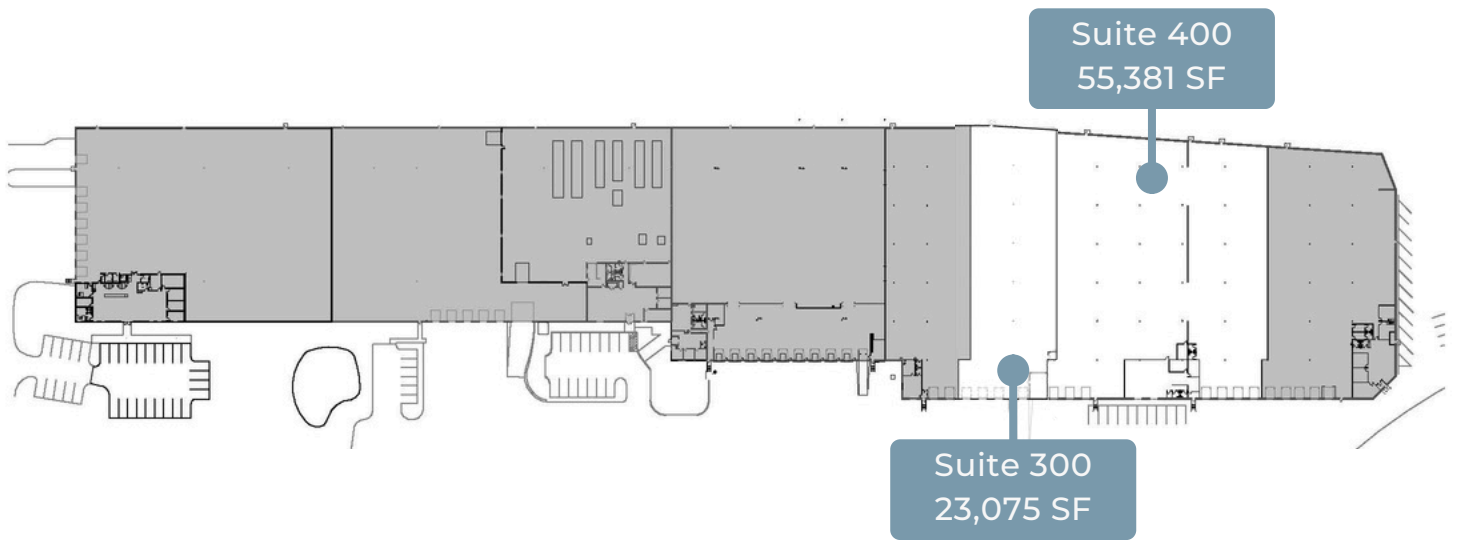
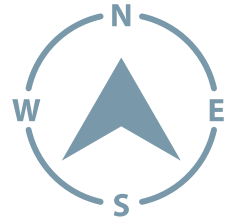

297,256 SF
Total SF



0.26/1000 SF
Parking Ratio



24'
Clear Height

AVAILABILITY SUMMARY

Suite 300

Date Available

60 day notice

Total SF

23,075 SF

Square Footage Breakdown

Office: 425 SF

Warehouse: 22,650 SF

Power

200 amp main disconnect, 3-phase

150 amp, 120/208V panel

250 amp, 277/480V panel

HVAC

Radiant Heater: Manuf: Roberts Gordon | Model: BH-200 | Serial: 9906-071-200-0137

Radiant Heater: Manuf: Roberts Gordon | Model: BH-200 | Serial: 9906-071-200-0134

Mini Split: Manuf: Mitsubishi | Model: MUZ-GL15NA | Serial: 5ZC00139 | Wall Mounted in Office,
Condenser on Roof | 1 ¼ Ton (15,000 BTU)

Loading Docks

Qty. 3 | 9' x 10'

Drive in Doors

Qty. 1 | 9' x 10'

Specialty Features

Freeway visibility and signage

Access to I-94 within half mile

Ability to add more power

AVAILABILITY SUMMARY

Suite 400

Date Available

Today

Total SF

55,381 SF

Square Footage Breakdown

Office: 3,253 SF

Warehouse: 52,128 SF

Power

200 amp main disconnect, 3-phase

150 amp, 120/208V panel

250 amp, 277/480V panel

HVAC

Radiant Heater: Manuf: Roberts Gordon | Model: BH-200 | Serial: 9906-071-200-0136

Radiant Heater: Manuf: Roberts Gordon | Model: BH-200 | Serial: 9901-071-200-0010

RTU: Manuf: Lennox | Model: TGA09052BM1Y | Serial: 5605K12234 | Tonnage: 7.5 ton

Loading Docks

Qty. 6 | 9' x 10'

Drive in Doors

Qty. 1 | 9' x 10'

Specialty Features

Freeway visibility and signage

Access to I-94 within half mile

Ability to add more loading and power

AVAILABILITY SUMMARY

Suites 300 & 400

Date Available

With 60 day notice

Total SF

78,456 SF

Square Footage Breakdown

Office: 3,678 SF

Warehouse: 74,778 SF

Power Suite 300

200 amp main disconnect, 3-phase

150 amp, 120/208V panel

250 amp, 277/480V panel

Power Suite 400

200 amp main disconnect, 3-phase

150 amp, 120/208V panel

250 amp, 277/480V panel

HVAC Suite 300

Radiant Heater: Manuf: Roberts Gordon | Model: BH-200 | Serial: 9906-071-200-0137

Radiant Heater: Manuf: Roberts Gordon | Model: BH-200 | Serial: 9906-071-200-0134

Mini Split: Manuf: Mitsubishi | Model: MUZ-GL15NA | Serial: 5ZC00139 | Wall Mounted in Office,
Condenser on Roof | 1 ¼ Ton (15,000 BTU)

HVAC Suite 400

Radiant Heater: Manuf: Roberts Gordon | Model: BH-200 | Serial: 9906-071-200-0136

Radiant Heater: Manuf: Roberts Gordon | Model: BH-200 | Serial: 9901-071-200-0010

RTU: Manuf: Lennox | Model: TGA09052BM1Y | Serial: 5605K12234 | Tonnage: 7.5 ton

Loading Docks

Qty. 9 | 9' x 10'

Drive in Doors

Qty. 2 | 9' x 10'

Specialty Features

Freeway visibility and signage

Access to I-94 within half mile

Ability to add more loading and power

AVAILABLE SPACE | SUITE 300

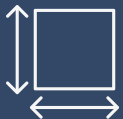
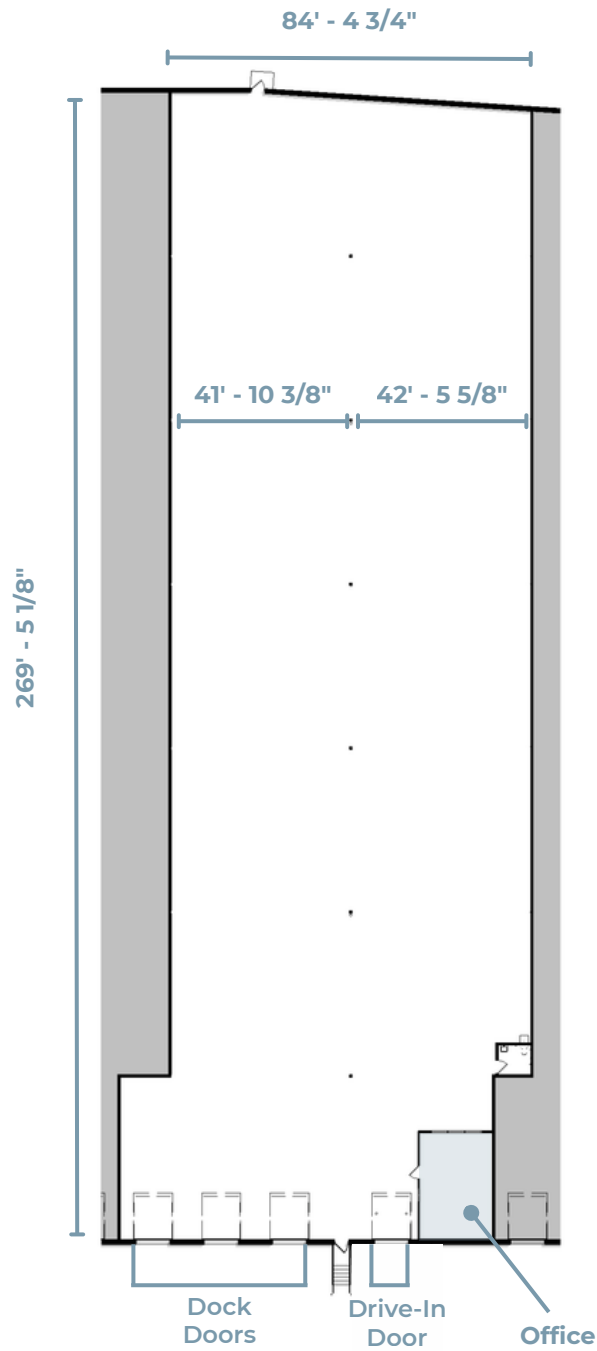

23,075 SF

Total



425 SF

Office



22,650 SF

Warehouse

AVAILABLE SPACE | SUITE 400

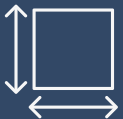
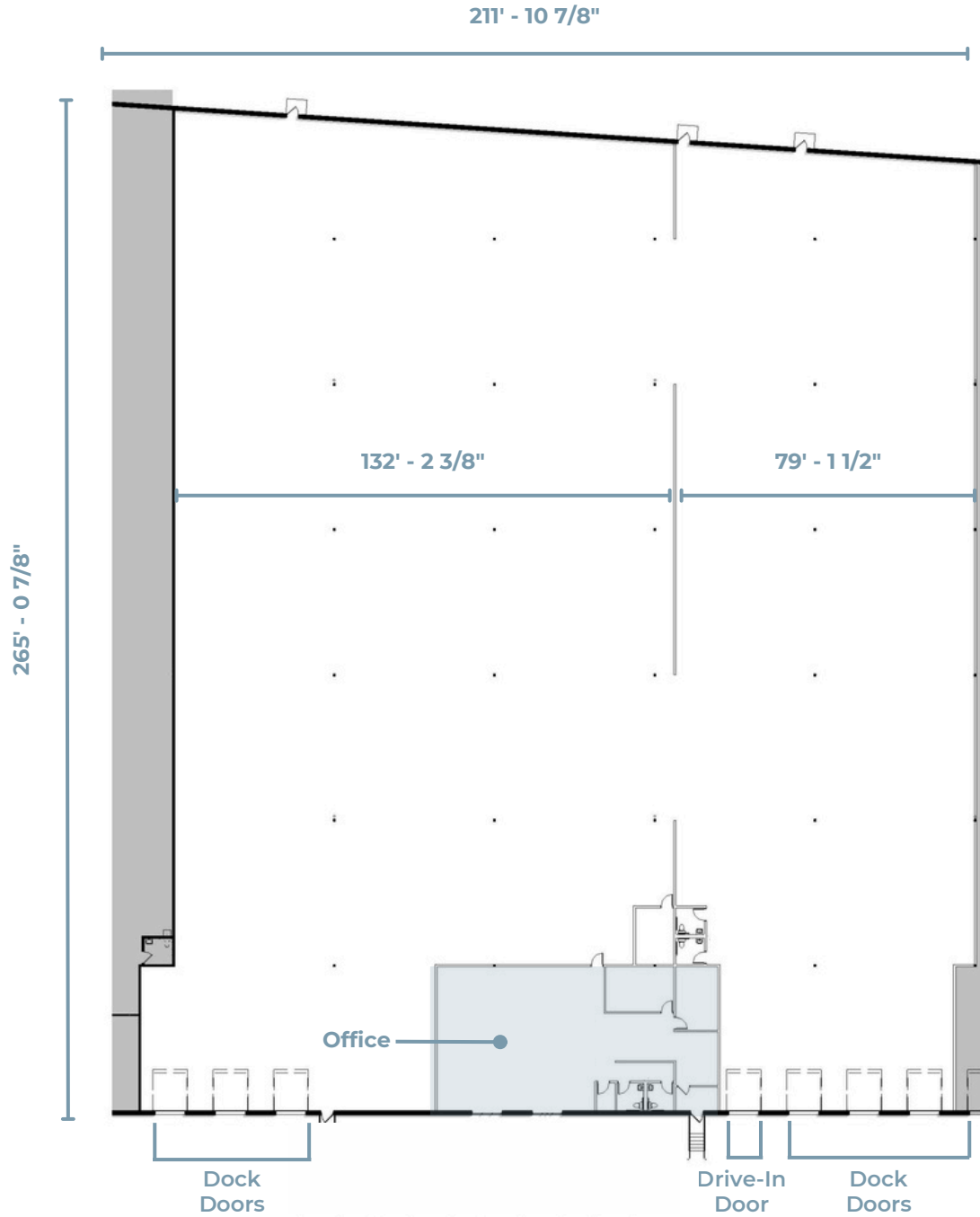

55,381 SF

Total



3,253 SF

Office



52,128 SF

Warehouse

ALTERNATIVE PLAN | SUITE 400

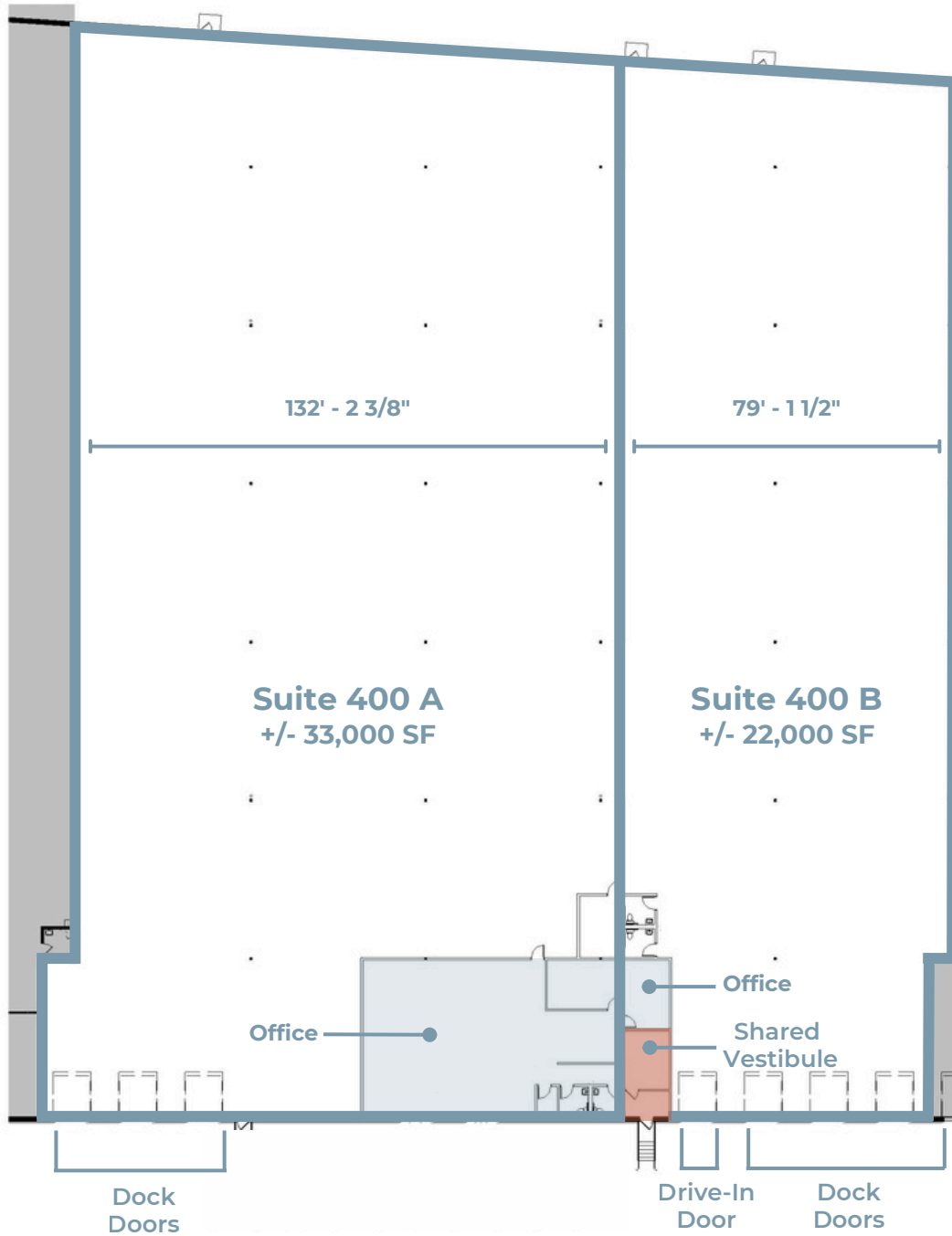

+/- 33,000 SF

Suite A



+/- 22,000 SF

Suite B

LOCATION

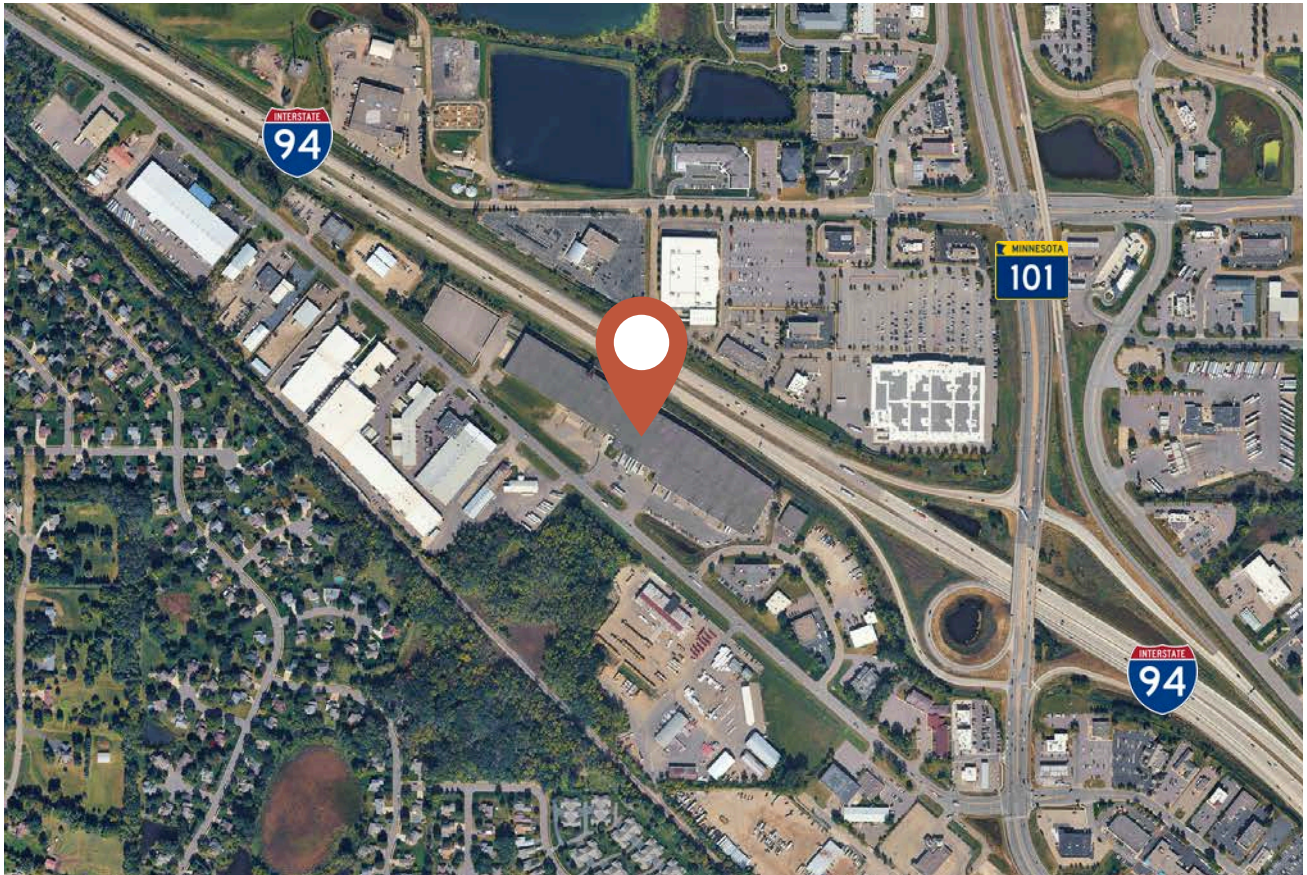

Restaurants within 2 miles

Clive's Roadhouse
Maynard's Restaurant of Rogers
R Social On Main
The Block Food + Drink
Lindas' Cafe
Short or Tall Eatery & Drink Hall
Rolls and Bowls Asian Cook House
Guadalajara Mexican Restaurant



Retail Shops within 2 miles

Comprehensive Inventory Solutions
MotoAlliance
Treasures Galore on 94
Antique Mall of Rogers
Kohl's
Custom Distribution
Target
Northern Tool + Equipment

PHOTOS



Nate Erickson, SIOR

nate.erickson@stackindustrial.com

612-201-8943

Alex Baron, SIOR

alex.baron@stackindustrial.com

763-226-3476

stackindustrial.com 

STACK
INDUSTRIAL PARTNERS