



A Historical Property

CBRE



History of 222 Minnetonka

Located in downtown Wayzata, 222 Minnetonka Ave S consists of one front building and a back building known as the Wise House.

The Wise House is a historical residential building, relocated to the site and renovated for client meetings and events.

222 Minnetonka sits just a block away from beautiful Lake Minnetonka, giving access to great retail and dining experiences.

About:



2 Buildings

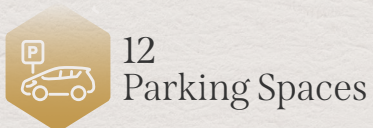

12
Parking Spaces



Total SF: 4,987 RSF

- Minnetonka (Front): 3,087 SF
- Wise House (Back): 1,900 SF



Two Floors

- Both buildings



Excellent Signage
Opportunity



The Wise House

- Constructed: ~1904
- Renovated: 2015
- Relocated: 2015



C-1 Zoning

- Office / professional services
- Residential uses



0.25 Acre Lot



Minnetonka Ave

- Constructed: ~1930
- Renovated: 2014 (new roof)
- Street visibility



Office Space

- Mix of private / open offices
- Conference room



Functional Layout

Aerial View

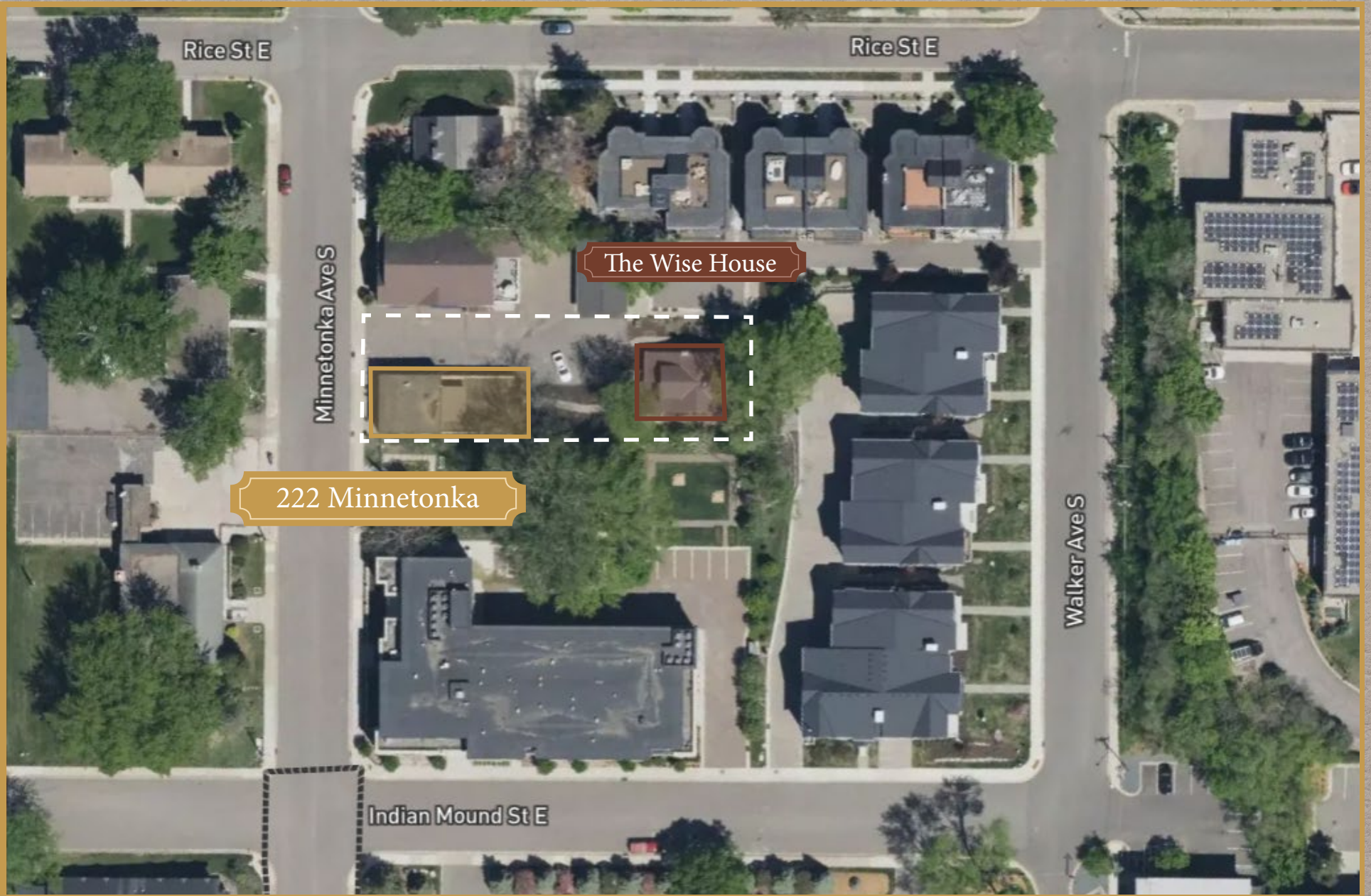

Downtown Wayzata



Floor Plan

222 Minnetonka

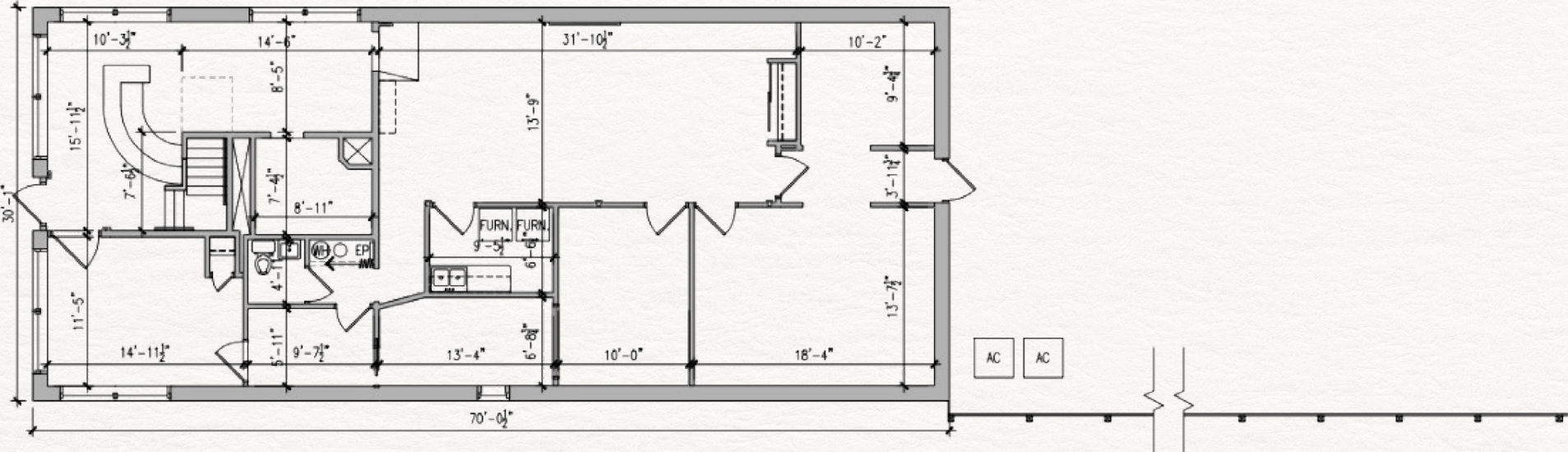
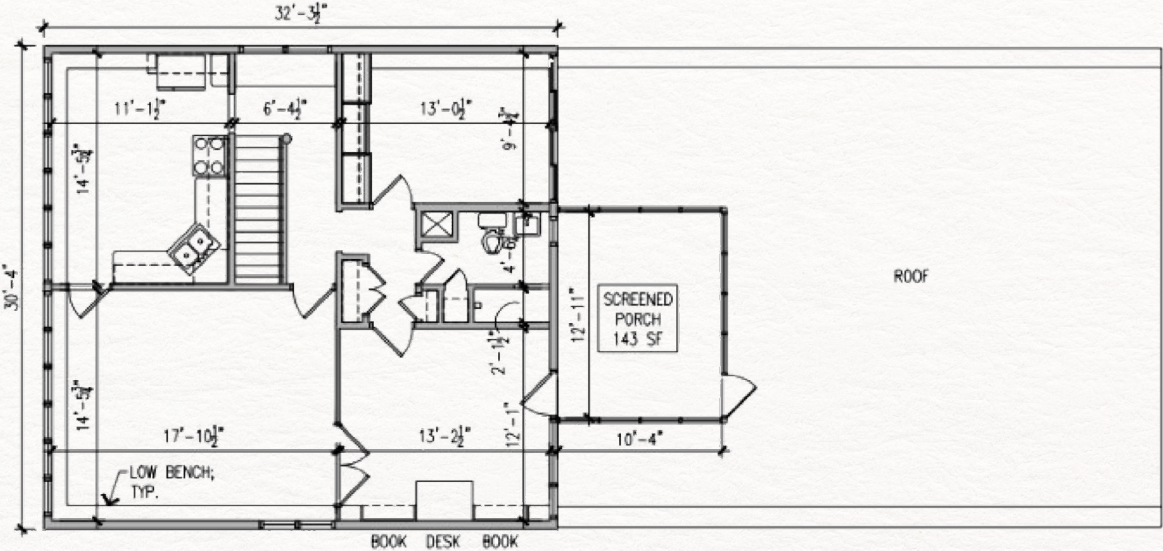

*Floor plan is for illustrative purposes only. It may not accurately represent the current layout due to potential renovations or demolition.



Contact Us:

Jim Freytag

Senior Vice President

+1 952 924 4616

jim.freytag@cbre.com

Bruce Carland

Vice President

+1 612 336 4207

bruce.carland@cbre.com

© 2026 CBRE, Inc. All rights reserved. This information has been obtained from sources believed reliable but has not been verified for accuracy or completeness. CBRE, Inc. makes no guarantee, representation or warranty and accepts no responsibility or liability as to the accuracy, completeness, or reliability of the information contained herein. You should conduct a careful, independent investigation of the property and verify all information. Any reliance on this information is solely at your own risk. CBRE and the CBRE logo are service marks of CBRE, Inc. All other marks displayed on this document are the property of their respective owners, and the use of such marks does not imply any affiliation with or endorsement of CBRE. Photos herein are the property of their respective owners. Use of these images without the express written consent of the owner is prohibited.

PMStudio_July2023

CBRE