

# For Lease

# 213 N. Magnolia Avenue

Orlando, FL 32801



Entire building available

**AVISON  
YOUNG**

**Jordan Bohannon**

Senior Vice President

407.219.3502

[jordan.bohannon@avisonyoung.com](mailto:jordan.bohannon@avisonyoung.com)

**Sean DuPree, CCIM**

Senior Vice President

407.440.6662

[sean.dupree@avisonyoung.com](mailto:sean.dupree@avisonyoung.com)



## Lease Overview

Avison Young is pleased to present this opportunity to Lease the free-standing office building located at 213 N. Magnolia Avenue, located in the heart of Downtown Orlando . The Property is located off the corner of the lighted intersection at N. Magnolia Avenue and E. Jefferson Street with easy walkability to the Orange County Courthouse, United States Post Office, Lake Eola and nearby eateries.

### PROPERTY HIGHLIGHTS

**SINGLE-STORY OFFICE BUILDING  
WITH PRIVATE ENTRY**

**1,400± RSF**

**TENANT IMPROVEMENT  
ALLOWANCE AVAILABLE**

**FASCIA SIGNAGE AVAILABLE**

**ZONING: AC-3A/T**

**STREET PARKING AVAILABLE**

**N. MAGNOLIA AVENUE FRONTAGE**

**LEASE RATE: \$18.00/RSF - NNN  
OPEX: \$4.15/RSF**



# Floorplan

SUITE 213

1,400± SF AVAILABLE

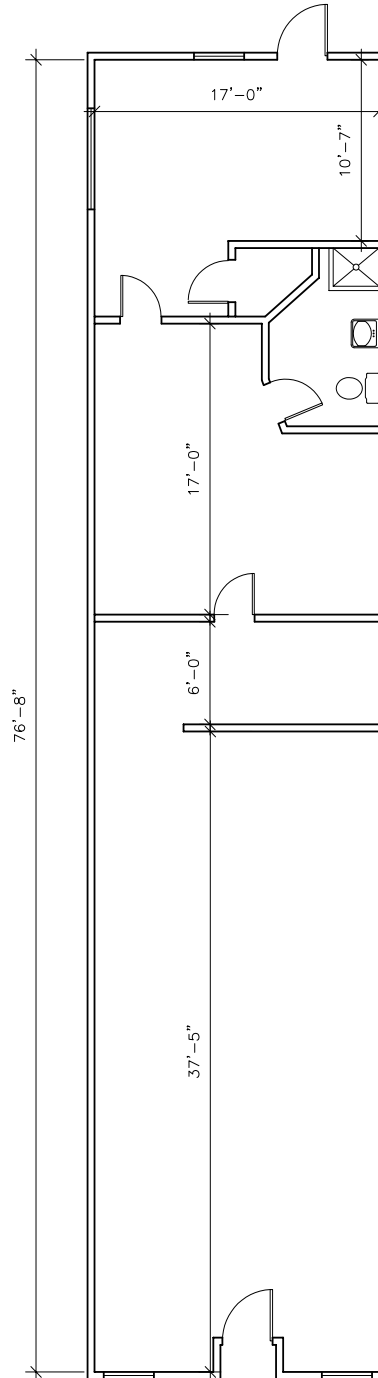

© 2026 Avison Young - Florida, LLC. All rights reserved. E. & O.E.: The information contained herein was obtained from sources which we deem reliable and, while thought to be correct, is not guaranteed by Avison Young.



**Jordan Bohannon**

Senior Vice President

407.219.3502

[jordan.bohannon@avisonyoung.com](mailto:jordan.bohannon@avisonyoung.com)

**Sean DuPree, CCIM**

Senior Vice President

407.440.6662

[sean.dupree@avisonyoung.com](mailto:sean.dupree@avisonyoung.com)

# Building a Better Downtown Orlando Project



The city is moving forward with plans to redesign Magnolia Avenue, from South Street north toward Livingston Street, to create a safer, more intuitive, and more walkable downtown corridor. Magnolia Avenue runs parallel to Orange Avenue and will serve as an alternative north-south route through the Historic Business District. Today, many downtown streets are one-way and built for fast, high-volume traffic, which can make walking, biking, transit use, and everyday navigation more difficult.

This project is part of a long-term effort to make downtown Orlando more vibrant and welcoming. Magnolia Avenue was converted into a one-way roadway in the 1950s to support commuter traffic after the construction of Interstate 4. Community input gathered through earlier planning efforts, including the 2003 Downtown Orlando Action Plan and a recent traffic study completed in 2022, emphasized the need for more walkable streets, better mobility options, and improved connections for everyone traveling downtown.

The current project will convert Magnolia Avenue back to a two-way street, remove most of the dedicated LYMMO bus lane, integrate bus operations into regular traffic, and add on-street parking to create a more attractive and pedestrian-friendly environment.

The anticipated time for project completion is Q2-2026.

© 2026 Avison Young - Florida, LLC. All rights reserved. E. & O.E.: The information contained herein was obtained from sources which we deem reliable and, while thought to be correct, is not guaranteed by Avison Young.



**Jordan Bohannon**  
Senior Vice President  
407.219.3502

[jordan.bohannon@avisonyoung.com](mailto:jordan.bohannon@avisonyoung.com)

**Sean DuPree, CCIM**  
Senior Vice President  
407.440.6662

[sean.dupree@avisonyoung.com](mailto:sean.dupree@avisonyoung.com)