



1 OF 3 BUILDINGS
IN A 450,000 SF
OFFICE CAMPUS

500 – 85,177 SF
AVAILABLE SPACE

NEWLY REMODELED
\$1,000,000 ATRIUM/LOBBY

COMPLIMENTARY
DIGITAL BILLBOARD
FOR ALL TENANTS

COMPLIMENTARY
FITNESS CENTER &
CONFERENCE FACILITIES

MINUTES FROM O'HARE
WITH IMMEDIATE
EXPRESSWAY ACCESS

Modern workspace solutions designed for teams
of every size, with flexible plans that fit any budget.

For information contact:

IGNACIO FELLER

Commercial Real Estate Director

(847) 777-9513

ifeller@ohareoffices.com

OhareOffices.com

PROPERTY OVERVIEW

O'Hare Offices is a professionally managed, 450,000-square-foot office campus spanning 28 landscaped acres along Lake Opeka. Located at 999, 1011, and 1111 East Touhy Avenue in Des Plaines, the campus features three five-story buildings with flexible, customizable office suites and a full range of tenant-focused amenities.

Just minutes from Chicago O'Hare International Airport—with immediate access to I-90 and CTA transit—O'Hare Offices delivers the connectivity and infrastructure businesses need for long-term growth, only 18 miles from downtown Chicago.



The information contained herein has been obtained from sources believed reliable; however, Owner and its representatives make no warranties or representations, express or implied, as to the accuracy or completeness of such information. All information is subject to errors, omissions, change of price, prior lease, or withdrawal without notice.

BUILDING FEATURES & AMENITIES

O'HARE OFFICES 



LOCATION & CONVENIENCE

Ideally positioned near major highways, public transit, and Chicago O'Hare International Airport—offering seamless regional and national access.



COMPLIMENTARY DIGITAL BILLBOARD

A high-visibility advertising platform along a major corridor, giving tenants a powerful way to elevate brand exposure.



COMPLIMENTARY VEHICLE CHARGING STATION

On-site EV charging that promotes sustainability and everyday convenience.



COMPLIMENTARY FITNESS CENTER

A fully equipped fitness center with lockers and showers—designed to promote employee wellness and support flexible workday routines.



COMPLIMENTARY ATRIUM EVENT SPACE

A spacious on-site venue available for company events, networking functions, and corporate gatherings.



COMPLIMENTARY CONFERENCE ROOMS

Professional, fully equipped conference and training spaces designed for client meetings, team collaboration, presentations, and workshops.



ON-SITE DINING

Fresh, convenient food options that help teams stay energized and productive without leaving the campus.



ON-SITE MANAGEMENT TEAM

An experienced, responsive management and engineering team providing dedicated service and day-to-day operational support.



MOVE-IN-READY & BUILT-TO-SUIT OFFICE SPACES

Versatile office layouts tailored to your operational needs, budget, and long-term growth plans.



LOCAL ATTRACTIONS

Surrounded by dining, retail, hospitality, and recreational destinations that enhance the workplace experience.

PREMIUM WORKSPACE. PRIME LOCATION. EXCEPTIONAL AMENITIES.

The O'Hare Offices Campus

Offers premium workspaces in a highly convenient location, enhanced by a wide range of modern amenities. With conference and training rooms, along with welcoming collaborative lounges, every detail is designed to support productivity, flexibility, and ease throughout your day.



O'HARE OFFICES



999 E. Touhy Ave
500-85,177 SF

AVAILABLE SUITES

Suite 170 | SF: 2,523

Suite 200 | SF: 13,772

Suite 240 | SF: 3,690

Suite 250 | SF: 6,942

Suite 333 | SF: 14,799

Suite 360 | SF: 2,951

Suite 375 | SF: 1,123

Suite 400 | SF: 6,480

Suite 460 | SF: 2,635

Suite 470 | SF: 1,772

Suite 480 | SF: 1,842

Suite 550 | SF: 5,223

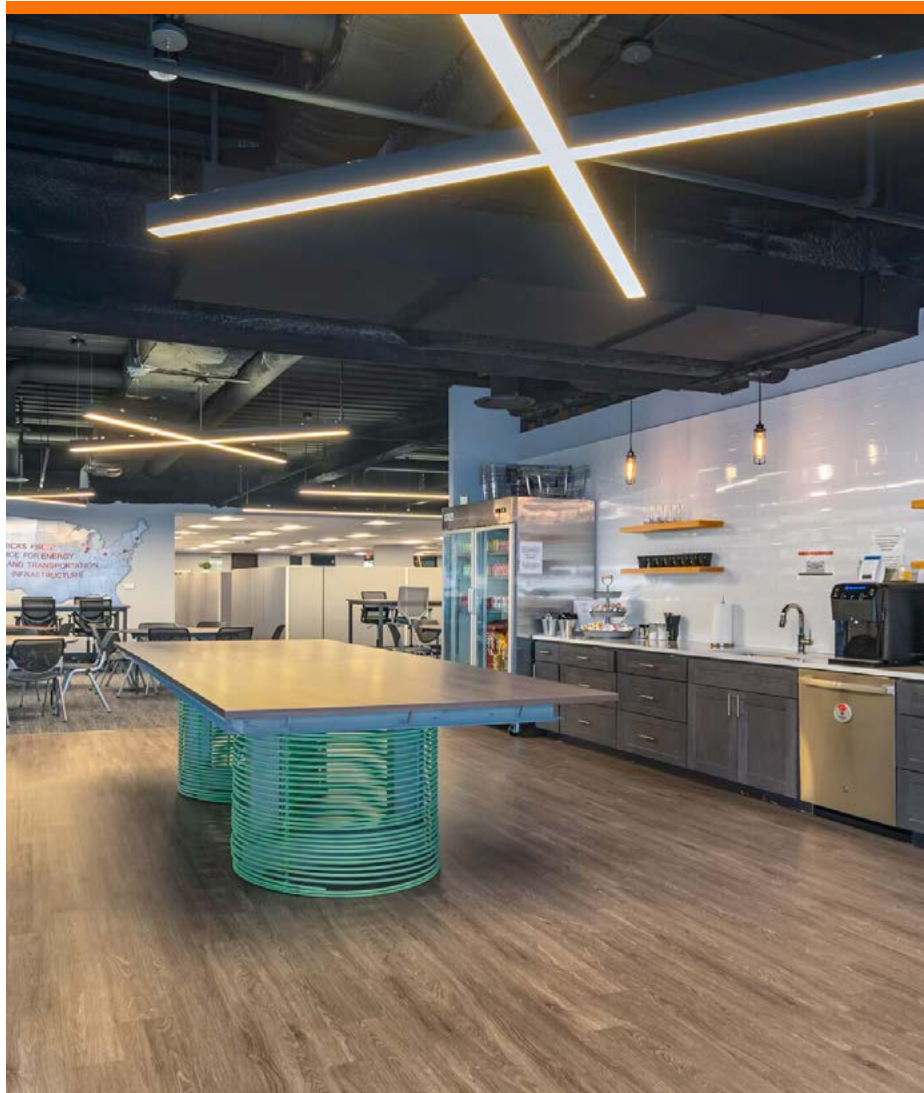

Building Type/Class
Office/B

Year Built/Renovated
1973/2019

Building Size
145,062 SF

Building Height
5 Stories

Typical Floor Size
29,012 SF

Parking
455 Spaces

FLOOR PLANS First Floor

99 East Touhy

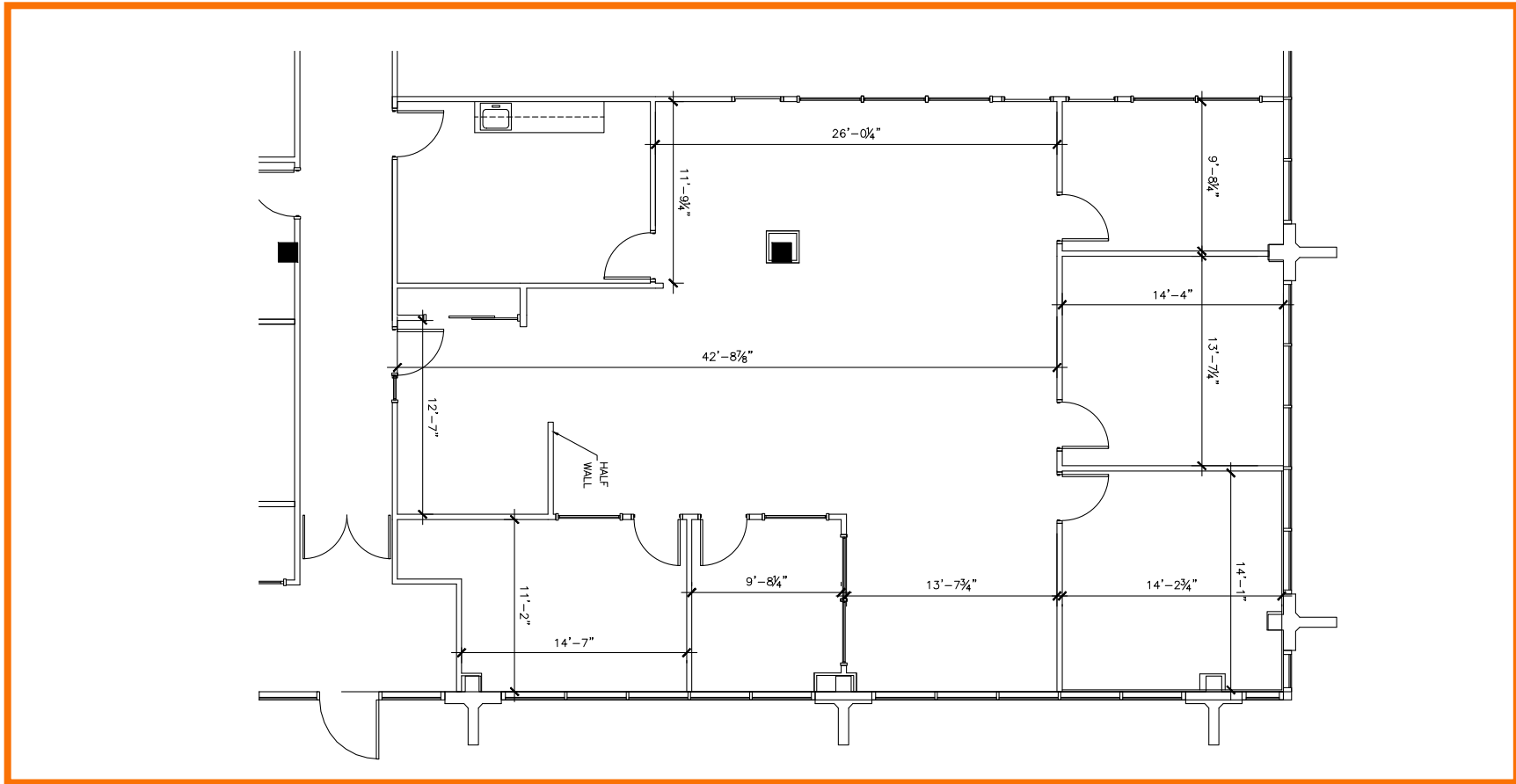

Suite 170 | SF: 2,523

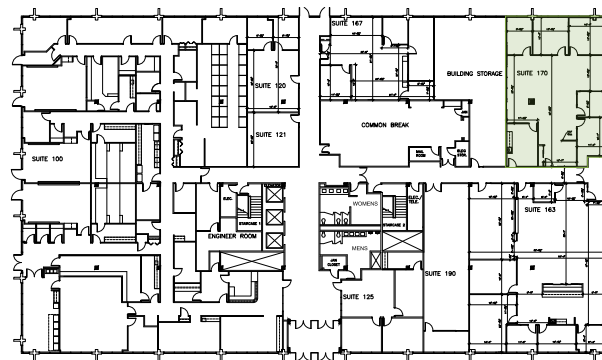

For information contact:
IGNACIO FELLER
Commercial Real Estate Director
(847) 777-9513
ifeller@ohareoffices.com
OhareOffices.com

FLOOR PLANS Second Floor

999 East Touhy

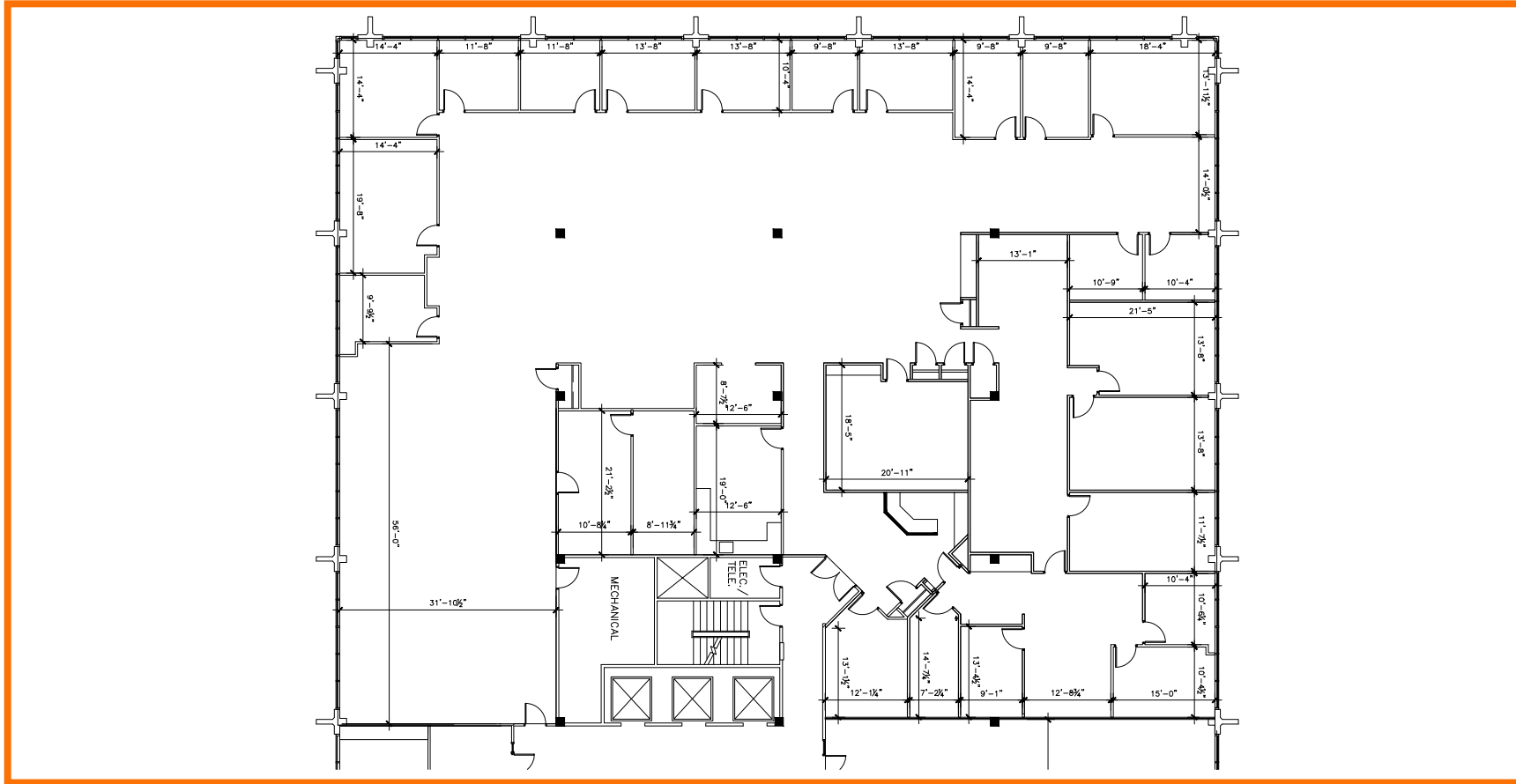

Suite 200 | SF: 13,772

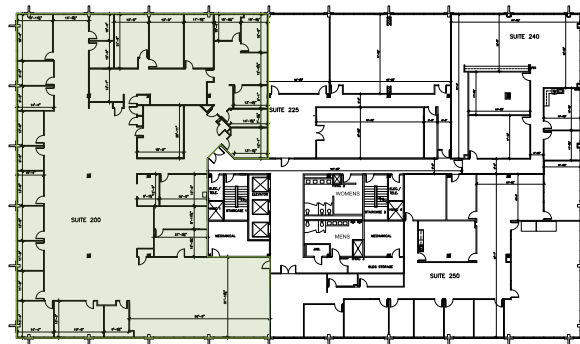

For information contact:
IGNACIO FELLER
Commercial Real Estate Director
(847) 777-9513
ifeller@ohareoffices.com
OhareOffices.com

FLOOR PLANS Second Floor

999 East Touhy

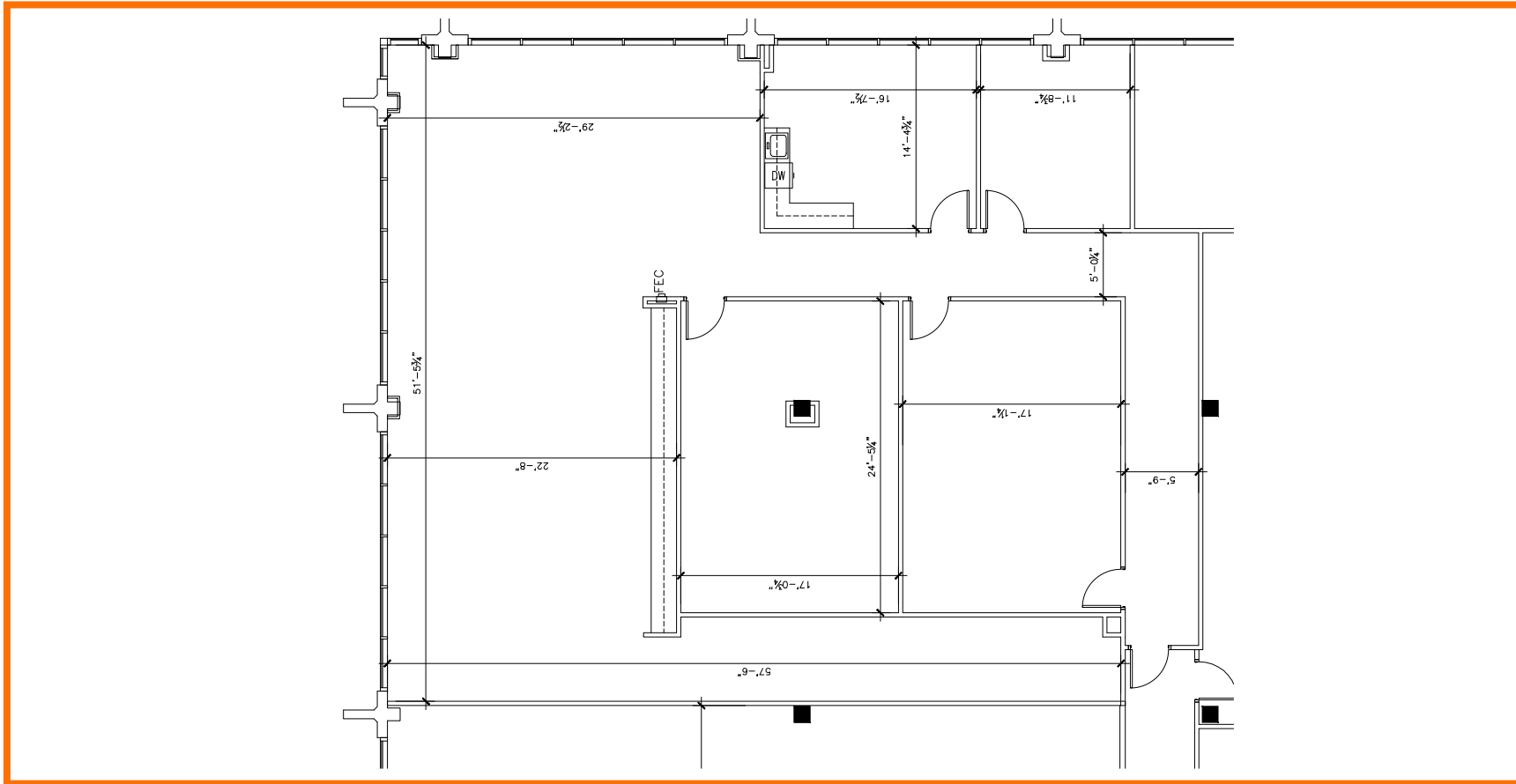

Suite 240 | SF: 3,690

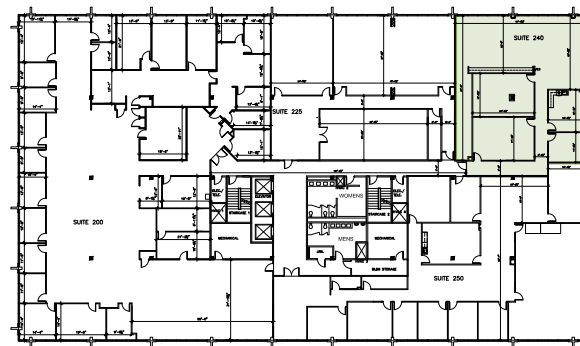

For information contact:
IGNACIO FELLER
Commercial Real Estate Director
(847) 777-9513
ifeller@ohareoffices.com
OhareOffices.com

FLOOR PLANS Second Floor

999 East Touhy

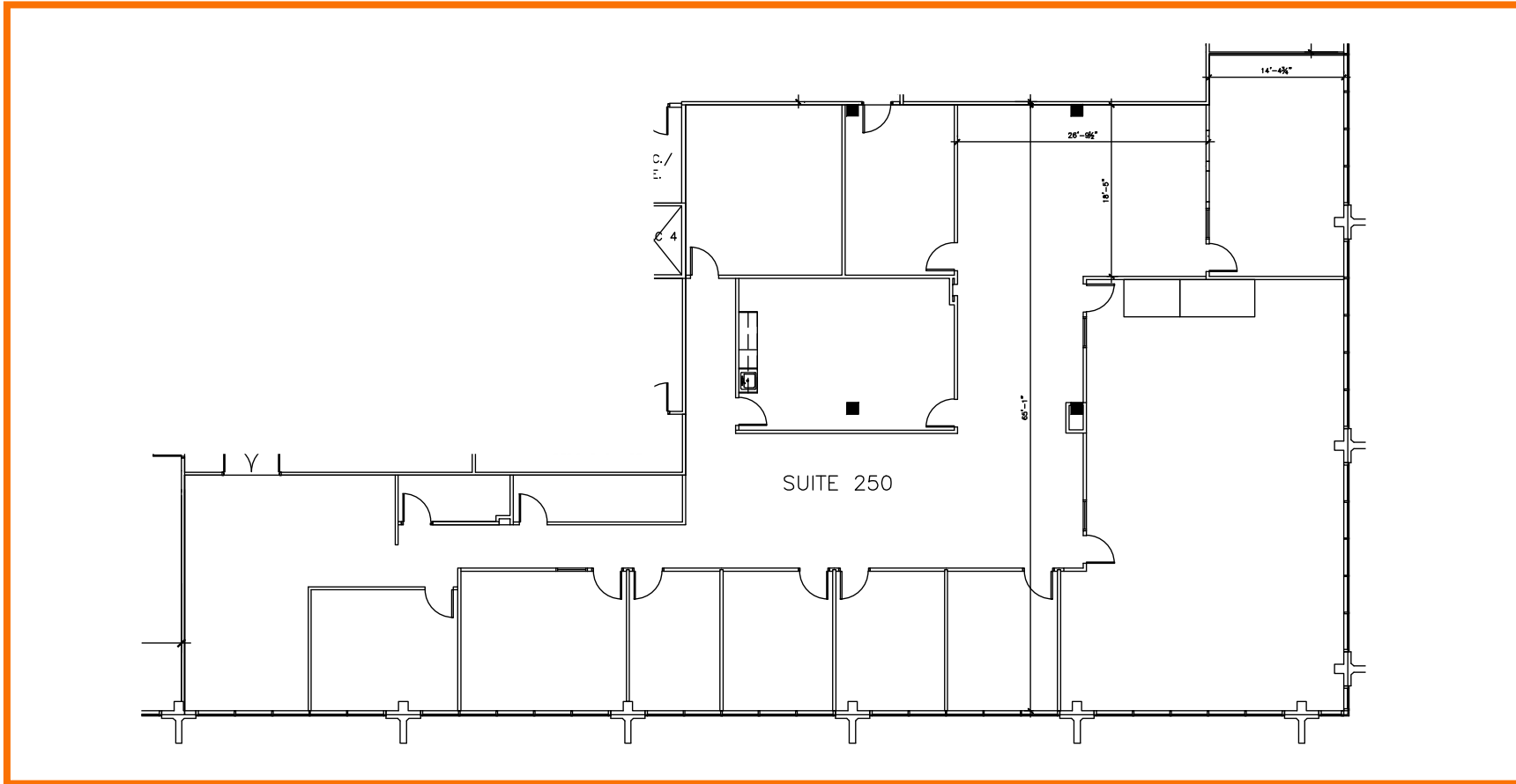

Suite 250 | SF: 6,942

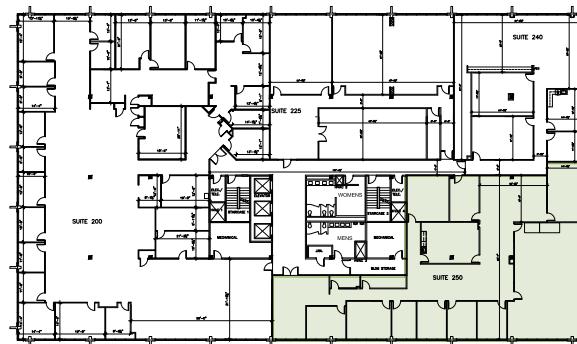

For information contact:
IGNACIO FELLER
Commercial Real Estate Director
(847) 777-9513
ifeller@ohareoffices.com
OhareOffices.com

FLOOR PLANS Third Floor

999 East Touhy

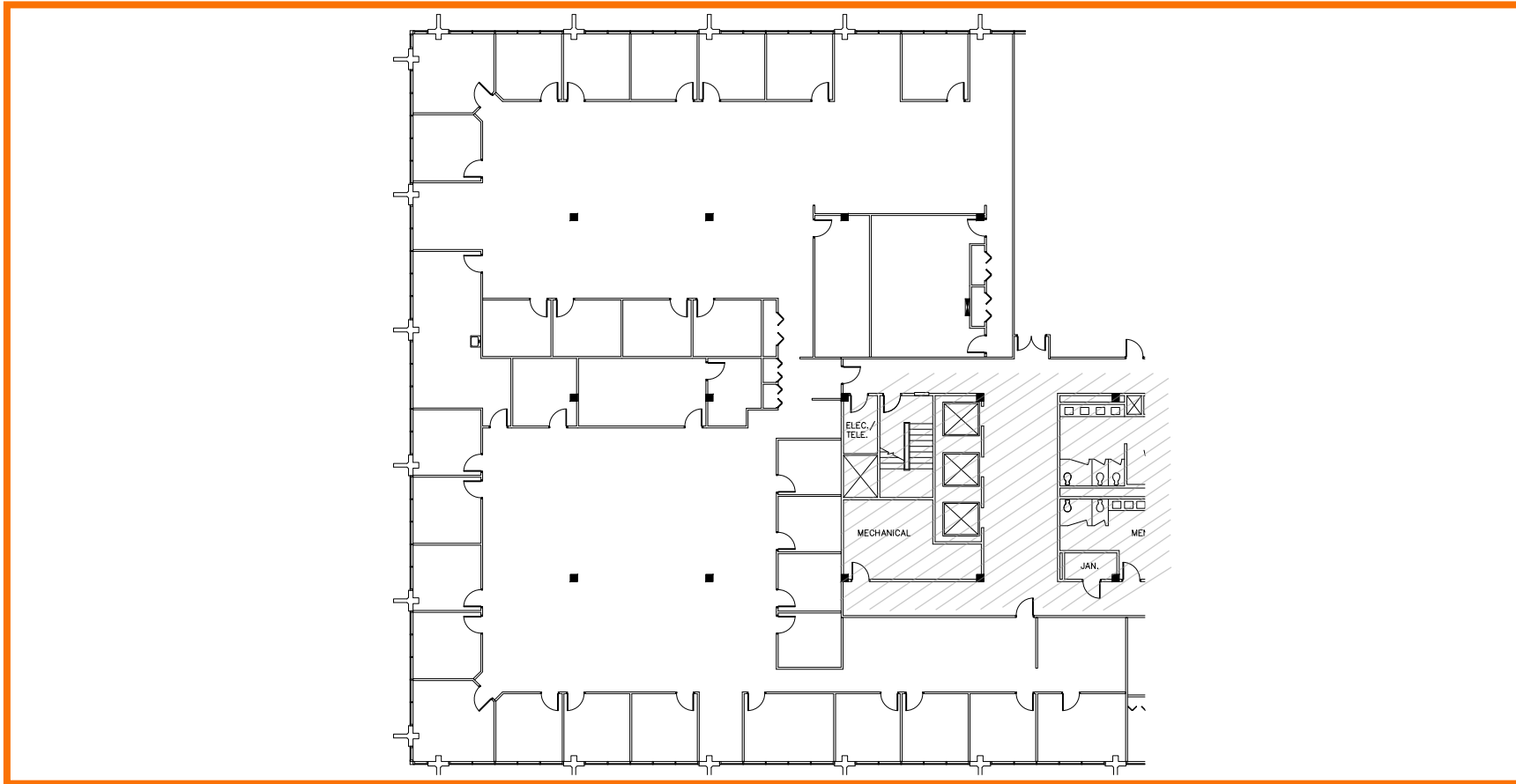

Suite 333 | SF: 14,799

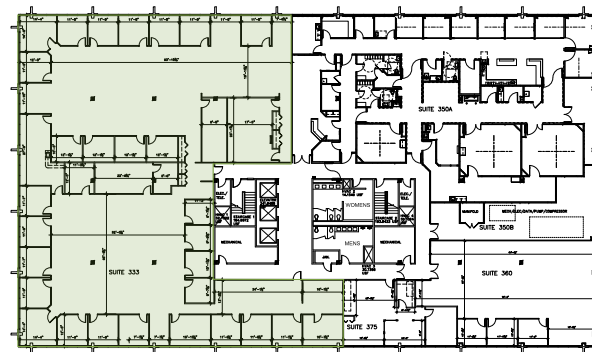

For information contact:
IGNACIO FELLER
Commercial Real Estate Director
(847) 777-9513
ifeller@ohareoffices.com
OhareOffices.com

FLOOR PLANS Third Floor

999 East Touhy

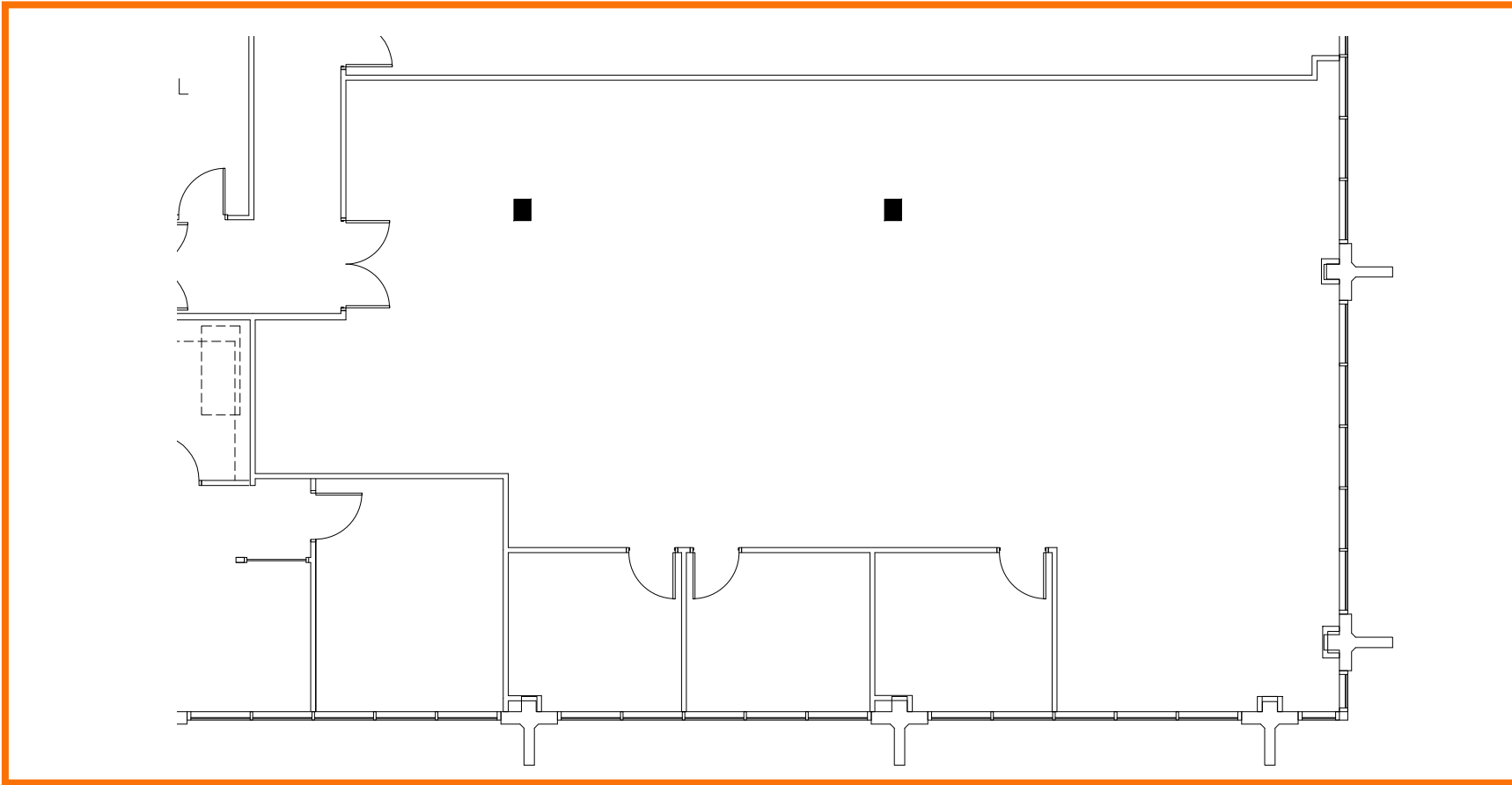

Suite 360 | SF: 2,951

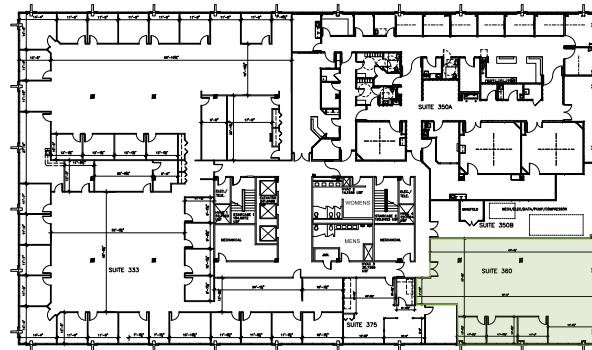

For information contact:
IGNACIO FELLER
Commercial Real Estate Director
(847) 777-9513
ifeller@ohareoffices.com
OhareOffices.com

FLOOR PLANS Third Floor

999 East Touhy

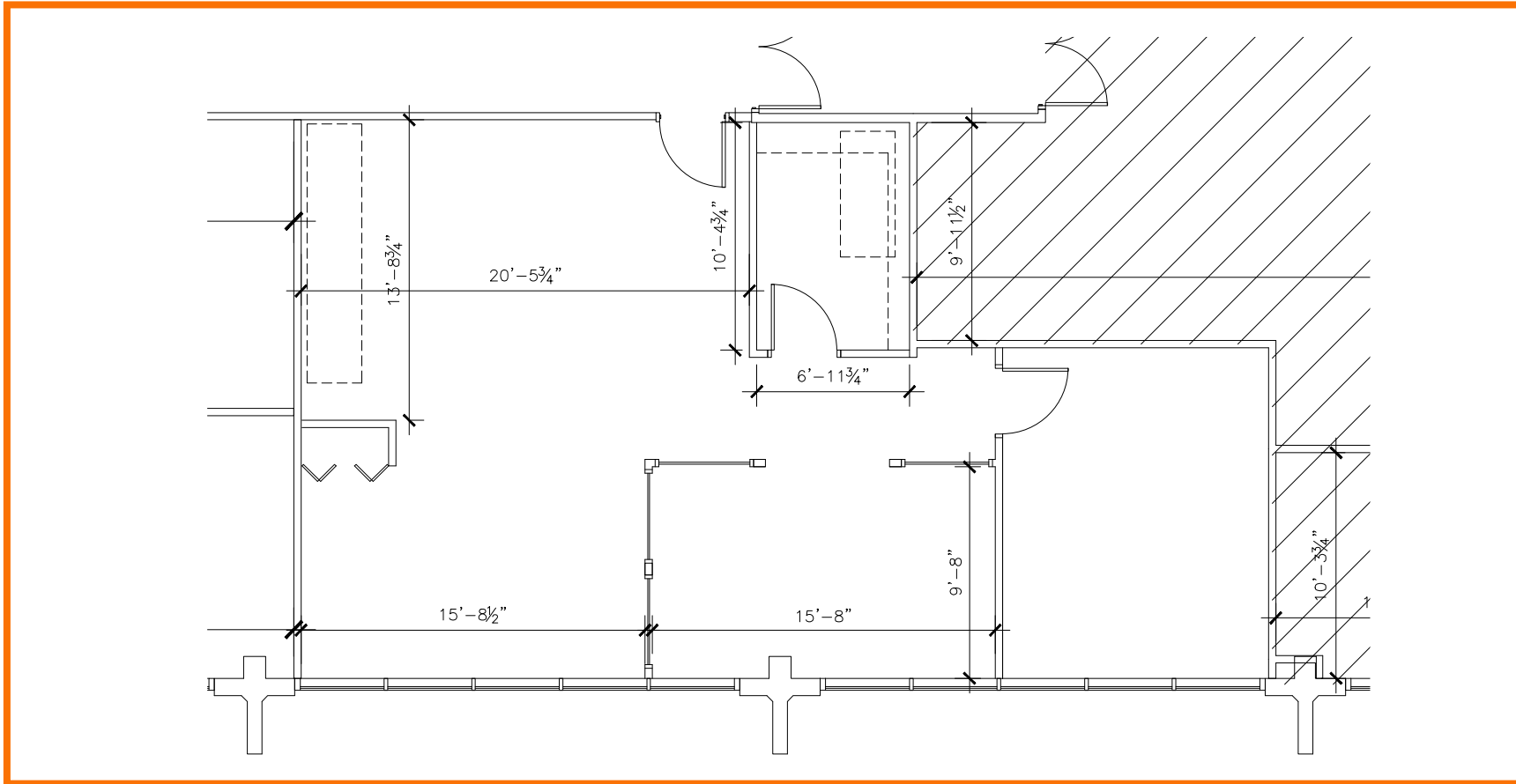

Suite 375 | SF: 1,123

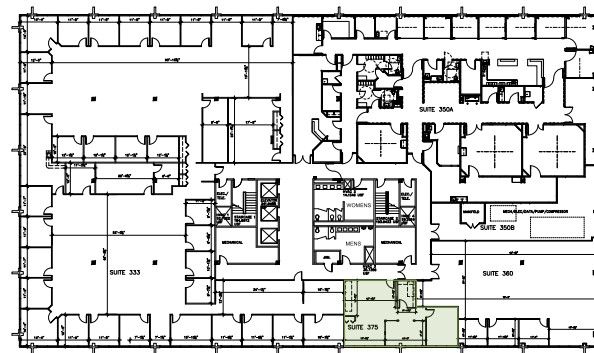

For information contact:
IGNACIO FELLER
Commercial Real Estate Director
(847) 777-9513
ifeller@ohareoffices.com
OhareOffices.com

FLOOR PLANS Fourth Floor

999 East Touhy

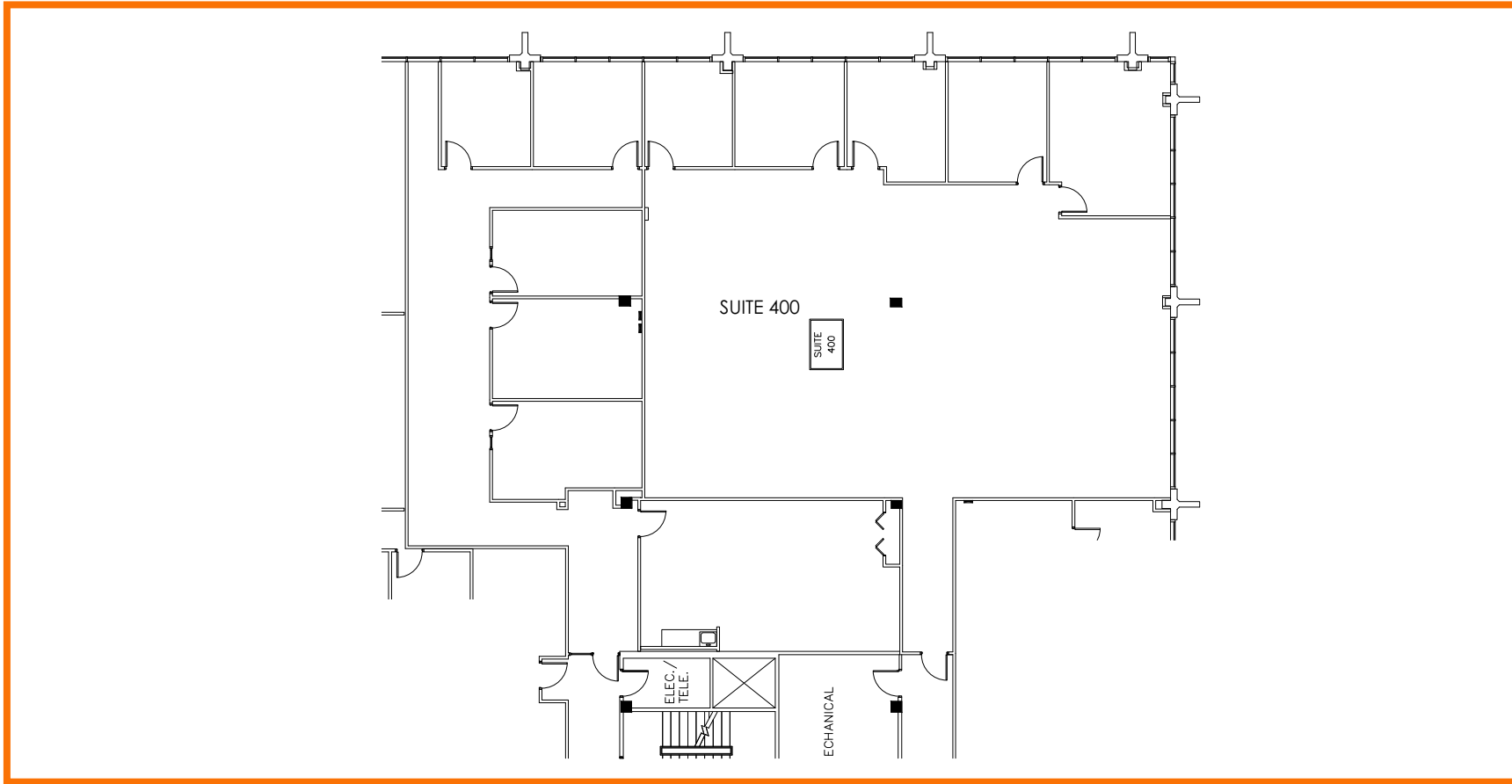

Suite 400 | SF: 6,480

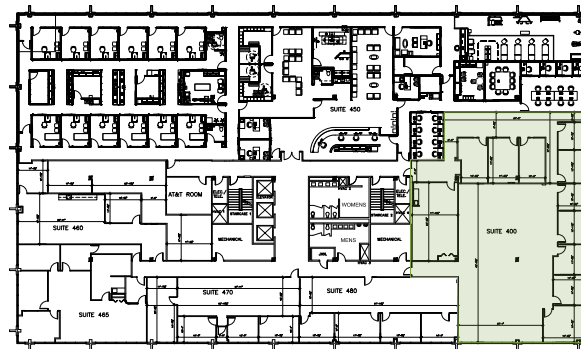

For information contact:
IGNACIO FELLER
Commercial Real Estate Director
(847) 777-9513
ifeller@ohareoffices.com
OhareOffices.com

FLOOR PLANS Fourth Floor

999 East Touhy

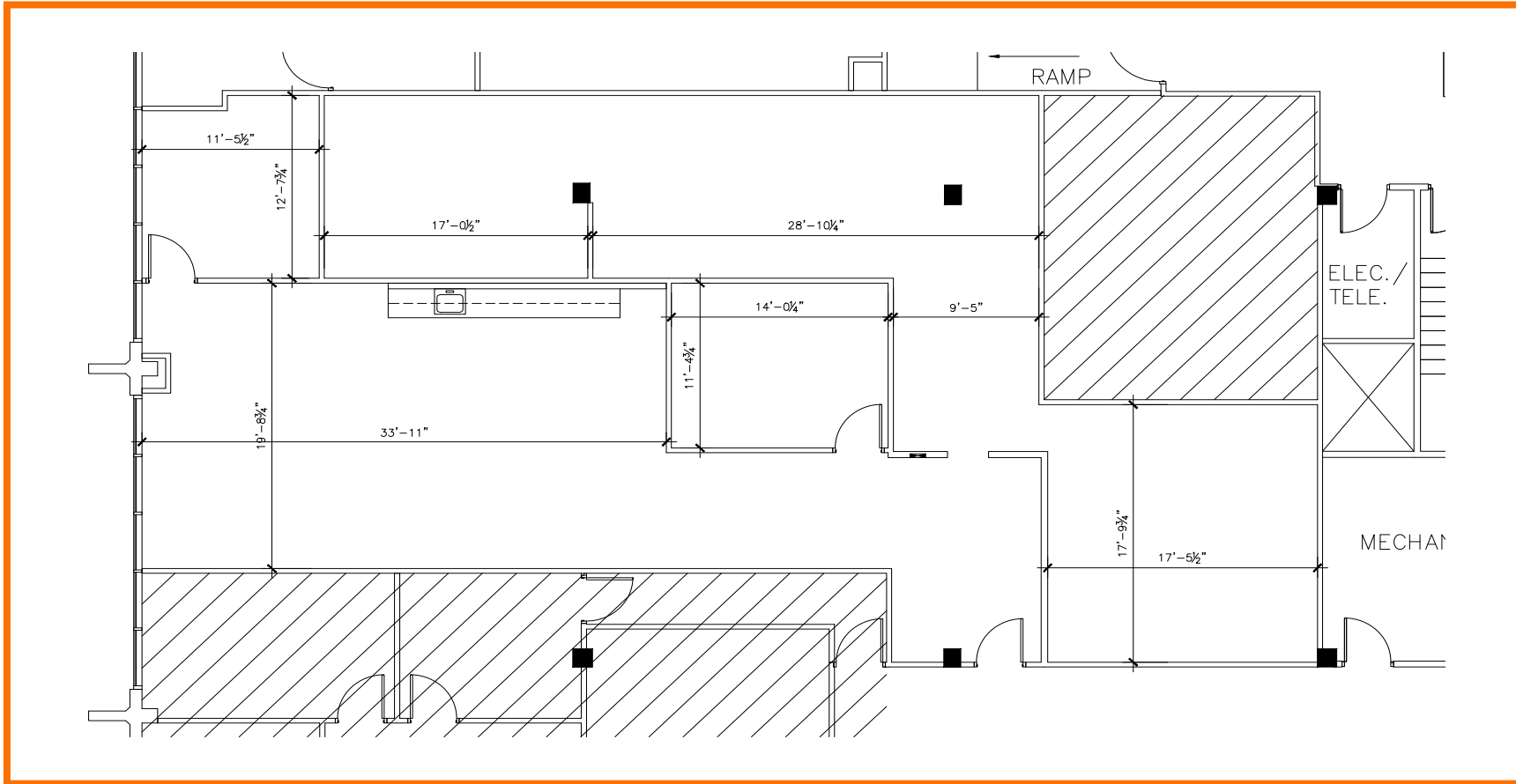

Suite 460 | SF: 2,635

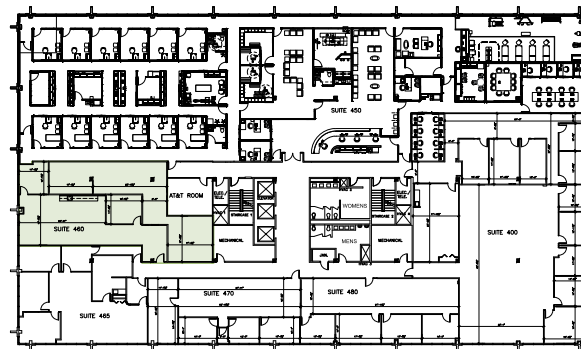

For information contact:
IGNACIO FELLER
Commercial Real Estate Director
(847) 777-9513
ifeller@ohareoffices.com
OhareOffices.com

FLOOR PLANS Fourth Floor

999 East Touhy

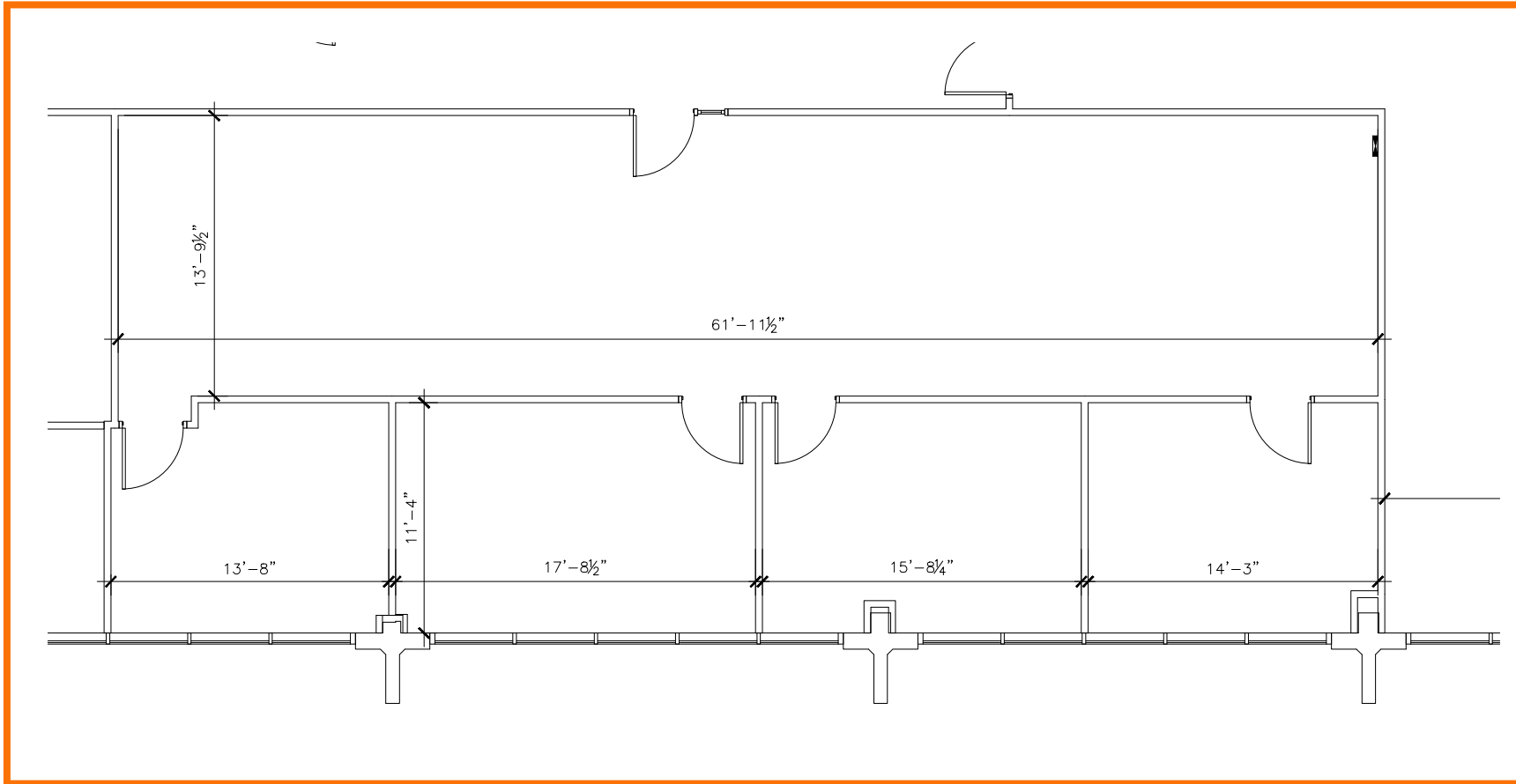

Suite 470 | SF: 1,772

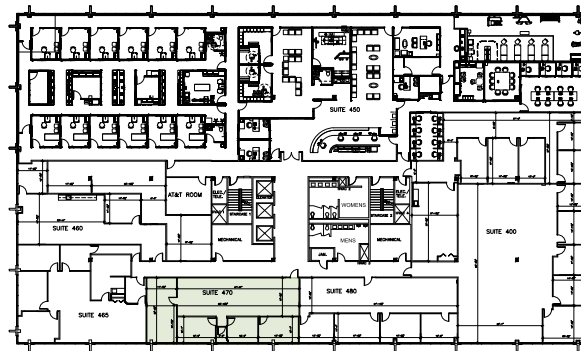

For information contact:
IGNACIO FELLER
Commercial Real Estate Director
(847) 777-9513
ifeller@ohareoffices.com
OhareOffices.com

FLOOR PLANS Fifth Floor

999 East Touhy

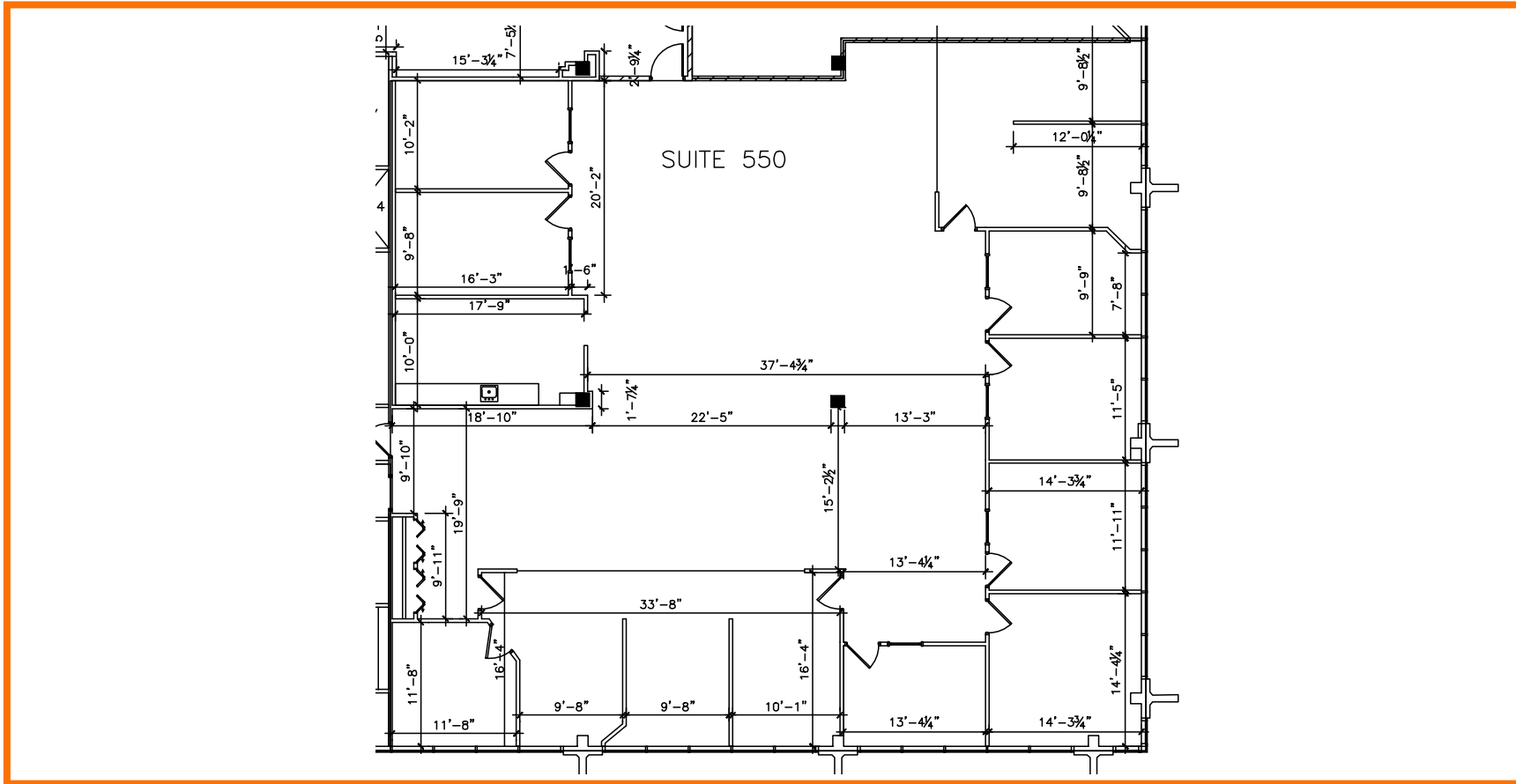

Suite 550 | SF: 5,223

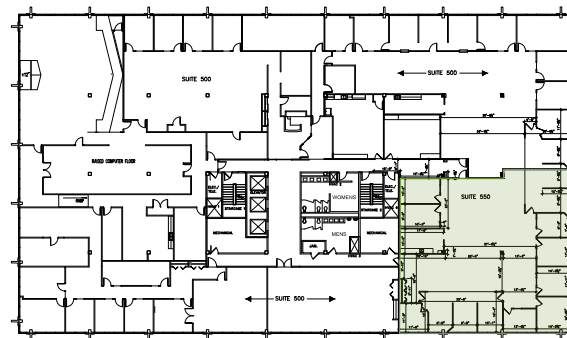

For information contact:
IGNACIO FELLER
Commercial Real Estate Director
(847) 777-9513
ifeller@ohareoffices.com
OhareOffices.com