

Building Sketch

Borrower/Client	Jon Parker			
Property Address	902 Broad St.			
City	Durham	County Durham	State NC	Zip Code
Lender	Not Applicable			

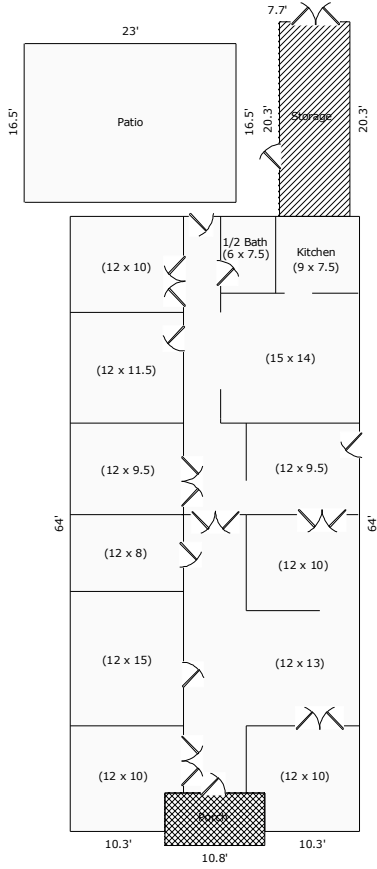

Sketch by Apex Sketch v6 Standard™

Comments:

AREA CALCULATIONS SUMMARY			
Code	Description	Net Size	Net Totals
GLA1	First Floor	1966.40	1966.40
P/P	Porch	59.40	
	Storage Area	156.31	
	Patio	379.50	595.21
Net LIVABLE Area		(rounded)	1966

LIVING AREA BREAKDOWN			
Breakdown			Subtotals
First Floor			
60.0	x	31.4	1884.00
4.0	x	10.3	41.20
4.0	x	10.3	41.20
3 Items			(rounded)
			1966