

# OFFICE SPACE FOR LEASE

## 615 WEST MOUNT PLEASANT AVENUE

LIVINGSTON, NJ 07039



### PROPERTY OVERVIEW

<b>BUILDING SF:</b>	20,000 SF
<b>AVAILABLE SF:</b>	1st Floor • 1,807 SF • 550 SF
<b>ASKING RATE:</b>	\$21.50 PSF plus electric
<b>AVAILABILITY:</b>	Immediate
<b>PARKING:</b>	5/1,000 SF
<b>LOCATION:</b>	<ul style="list-style-type: none"><li>• Direct access to Route 10 East and West</li><li>• Located off of the Livingston Circle</li><li>• Close proximity to Eisenhower Parkway and I-280</li></ul>

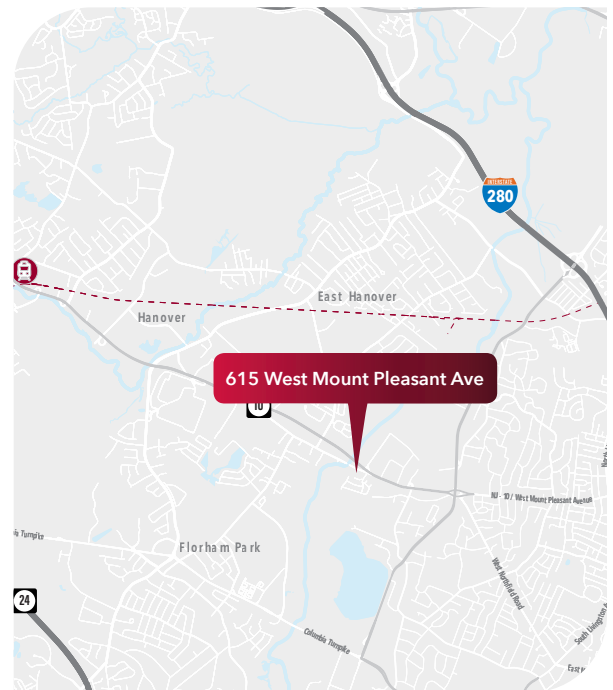

### FOR MORE INFORMATION CONTACT EXCLUSIVE BROKER:

Doug Rowe  
drowe@lee-associates.com  
C 646.483.0501

All information furnished regarding property for sale, rental or financing is from sources deemed reliable, but no warranty or representation is made to the accuracy thereof and same is submitted to errors, omissions, change of price, rental or other conditions prior to sale, lease or financing or withdrawal without notice. Buyer acknowledges that Lee & Associates of New Jersey, LLC ("Broker") has not verified the information contained herein and does not make any representation about its accuracy. Buyer should confirm information contained in the Offering using its own sources. No liability of any kind is to be imposed on Broker herein.

**OFFICE SPACE FOR LEASE**  
**615 WEST MOUNT PLEASANT AVENUE**  
LIVINGSTON, NJ 07039

**FLOOR PLANS**

**1ST FLOOR - 1,807 SF**

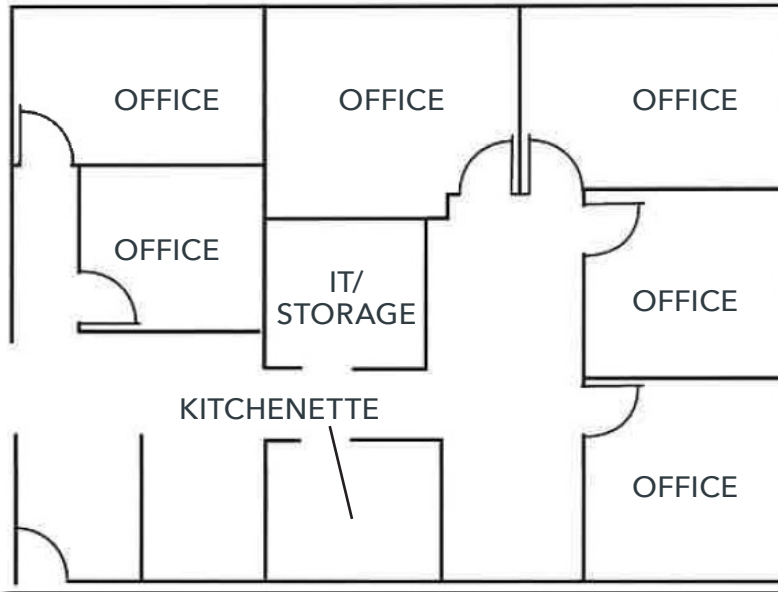

**1ST FLOOR - 550 SF**

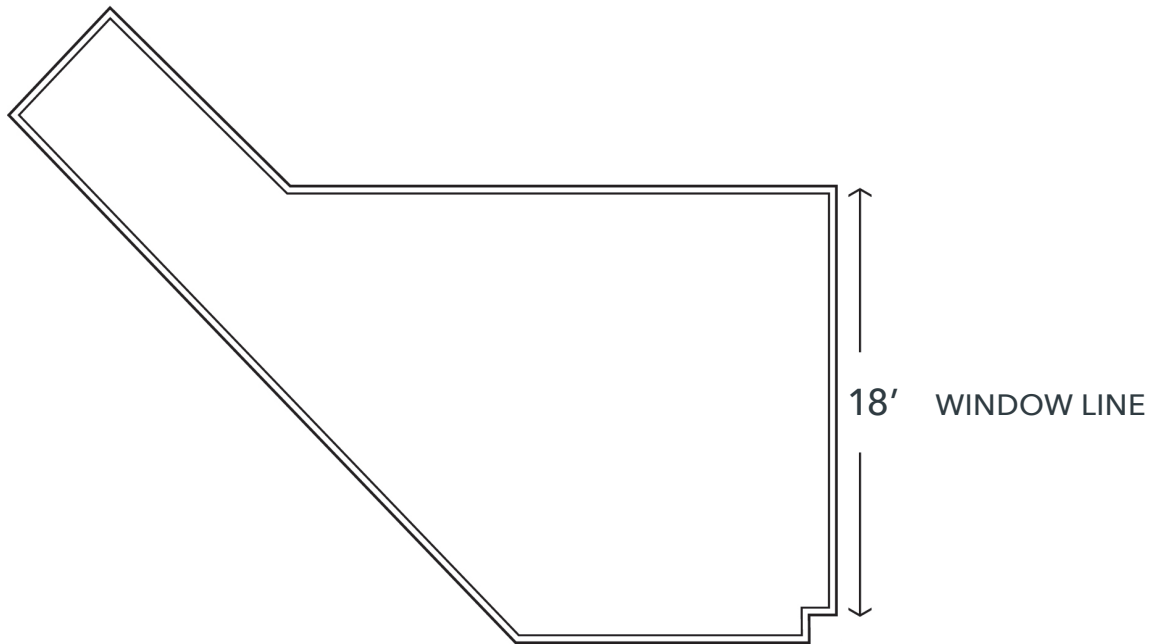

**FOR MORE INFORMATION CONTACT EXCLUSIVE BROKER:**

**Doug Rowe**  
drowe@lee-associates.com  
C 646.483.0501

All information furnished regarding property for sale, rental or financing is from sources deemed reliable, but no warranty or representation is made to the accuracy thereof and same is submitted to errors, omissions, change of price, rental or other conditions prior to sale, lease or financing or withdrawal without notice. Buyer acknowledges that Lee & Associates of New Jersey, LLC ("Broker") has not verified the information contained herein and does not make any representation about its accuracy. Buyer should confirm information contained in the Offering using its own sources. No liability of any kind is to be imposed on Broker herein.