

Greenville Crossing

4001-4029 KENNETT PIKE, GREENVILLE, DE 19807



MULTIPLE SPACES FOR LEASE



PROPERTY MANAGEMENT

Greenville Crossing

Property Managed by **B P G** | 3 6 0

BPG | 360 is a **full-service real estate asset and property management company** that strives to exceed the expectations of every tenant and owner they serve. The company actively manages more than six million square feet of commercial properties in the Maryland to Philadelphia office corridor, which includes properties both in The Buccini/Pollin Group's portfolio as well as those controlled by third-party owners. BPG 360's commercial operations team effectively touches every aspect of property management. With a 25 year history of managing commercial, hotel, retail and residential properties, every member brings their own experience and ideas to the table to provide an exceptional business model. BPG 360 is all about providing best in class customer service to the owners we represent, the tenants we serve, the vendor partnerships we culture and the fellow associates we work with every day.

BPG | 360 boasts one of the east coast's deepest benches of professionals with a very broad talent base of real estate and mechanical backgrounds. Our core team experience includes master electricians and plumbers, crafted painters, HVAC engineers, and landscapers along with experienced property managers, tax and financial analysts, construction managers and law enforcement personnel. It brings together top executives with experiences from the nation's leading real estate companies. This team marries their institutional backgrounds with a very entrepreneurial and pro-active tenant-focused platform.

The team maximizes the value of its assets with a hands-on, progressive management approach, enhancing financial performance through increased operating efficiency, asset repositioning, and rehabilitation strategies. The BPG 360 team carefully designs custom strategic plans to meet the challenges and opportunities faced by each specific property while optimizing value and performance based on the owner's specific goals.

PROPERTY FACT SHEET

One Greenville Crossing



General Site Information

Description:

- Situated in the heart of Greenville, DE, an ultra-affluent community with a captive mature residential population
- Located along Route 52, center lies at the heart of Greenville's retail corridor with close proximity to Route 202 and Wilmington; Rt. 52 links Greenville to affluent PA suburbs, Kennett Square and Chadds Ford
- Companies maintaining a significant local office presence include: Bank of America, Astrazeneca, and DuPont's World Headquarters
- Highly visible space ideal for higher-end community uses

Address:

4007-4029 Kennett Pike Greenville, DE 19807

Year Built:

1950, renovated in 2007

Property Type:

Retail

Anchor Tenants:

Walgreens, Wells Fargo Bank, and The BBC Tavern & Grill

Min. Divisible:

1,027 SF

Gross Leasable Area:

63,012 SF

Public Transportation:

Philadelphia International Airport – 23.8 miles • Wilmington Amtrak Station – 6.1 Miles

Demographics:

	1 Mile	3 Mile	5 Mile
Population	2,835	51,030	172,536
Households	1,370	22,964	71,312
Average Household Income	\$197,591	\$112,292	\$93,549

PROPERTY FACT SHEET

Two Greenville Crossing



General Site Information

Description: First class office/specialty retail building located in the heart of Greenville. 4001 Kennett Pike has elevator access to all floors and a lower level covered parking garage. Amenities in the building are within walking distance include numerous restaurants, banks, shipping and postal services, and high quality specialty shopping.

Located on Route 52 at Hillside Road, just north of Route 141. Here, Delaware's "corporate corridor" intersects with its most prestigious residential area. Route 52 is a commuter route linking downtown Wilmington and the 141 corridor with affluent suburbs in Delaware and southern Pennsylvania. Easy access to Wilmington, I-95, and Route 202. 3 miles from downtown Wilmington. Location not subject to city wage taxes or city gross receipts taxes.

Location: 4001 Kennett Pike Greenville, DE 19807

Year Built: 1990

Property Type: Retail and Office

Anchor Tenants: Purebread Deli, Joseph A. Banks

Min. Divisible: 956 SF

Max. Contiguous: 1,512 SF

Gross Leasable Area: 66,177 SF

Public Transportation: Philadelphia International Airport – 23.8 miles • Wilmington Amtrak Station – 6.1 Miles

Demographics:

	1 Mile	3 Mile	5 Mile
Population	2,835	51,030	172,536
Households	1,370	22,964	71,312
Average Household Income	\$197,591	\$112,292	\$93,549

GREENVILLE CROSSING

One Greenville Crossing



GREENVILLE CROSSING

Two Greenville Crossing



PROPERTY OVERVIEW

One Greenville Crossing • Two Greenville Crossing



LOCAL RETAIL MAP

One Greenville Crossing • Two Greenville Crossing



LEASING PLANS - BUILDING 1

One Greenville Crossing

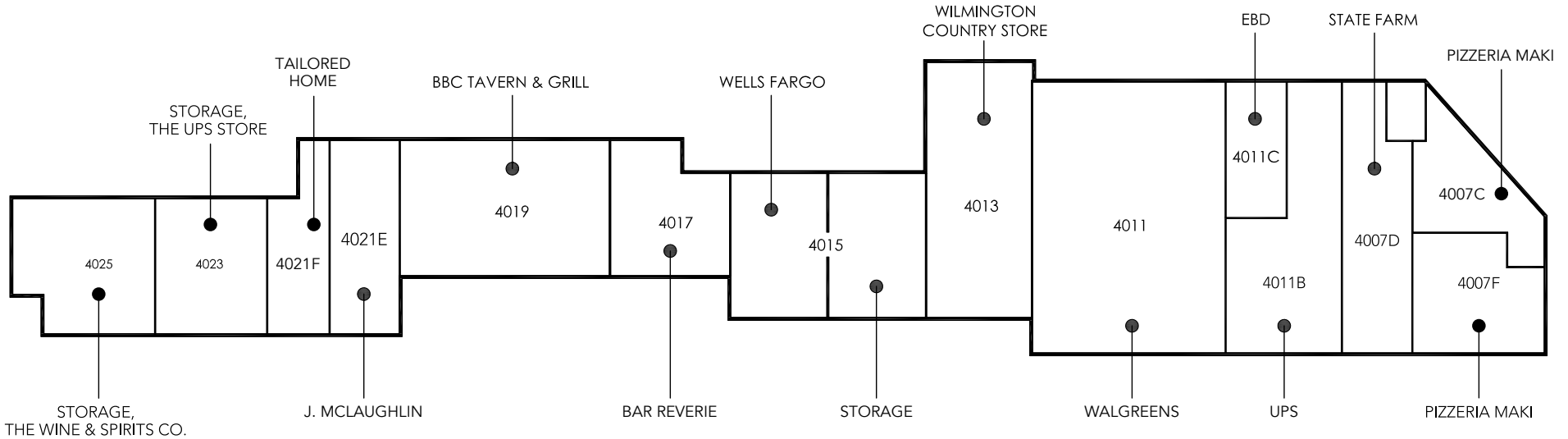

LOWER LEVEL FLOOR PLAN

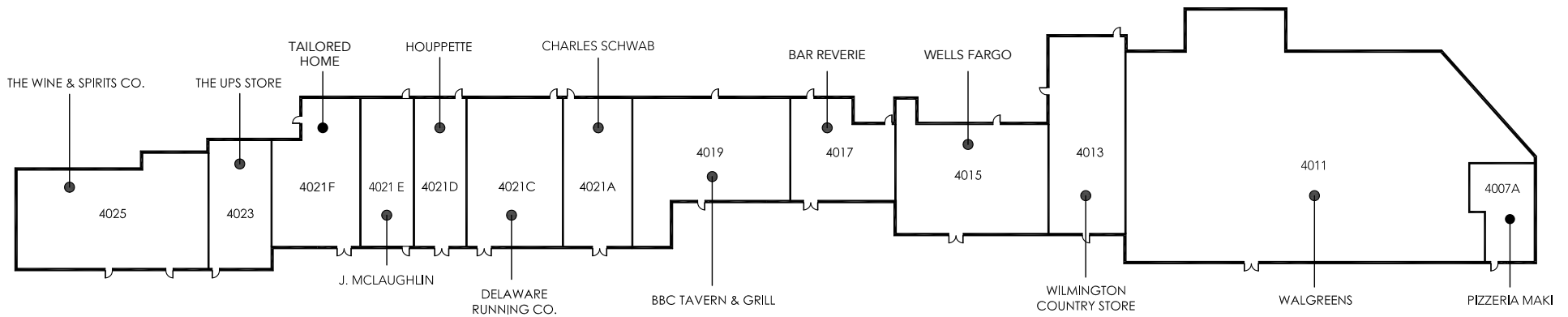

FIRST FLOOR PLAN

LEASING PLANS - BUILDING 2

Two Greenville Crossing

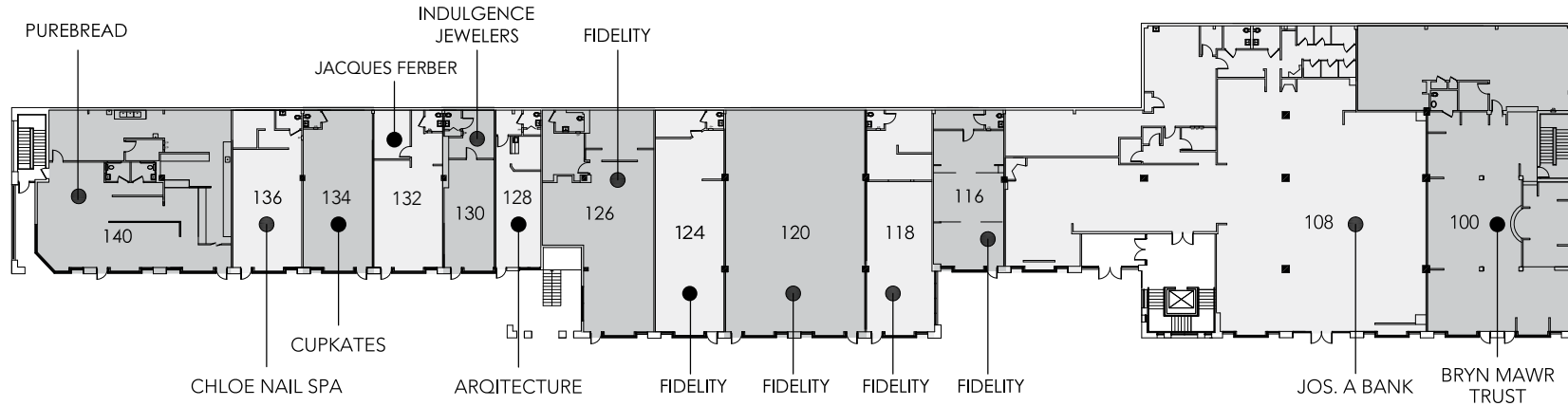

FIRST FLOOR PLAN

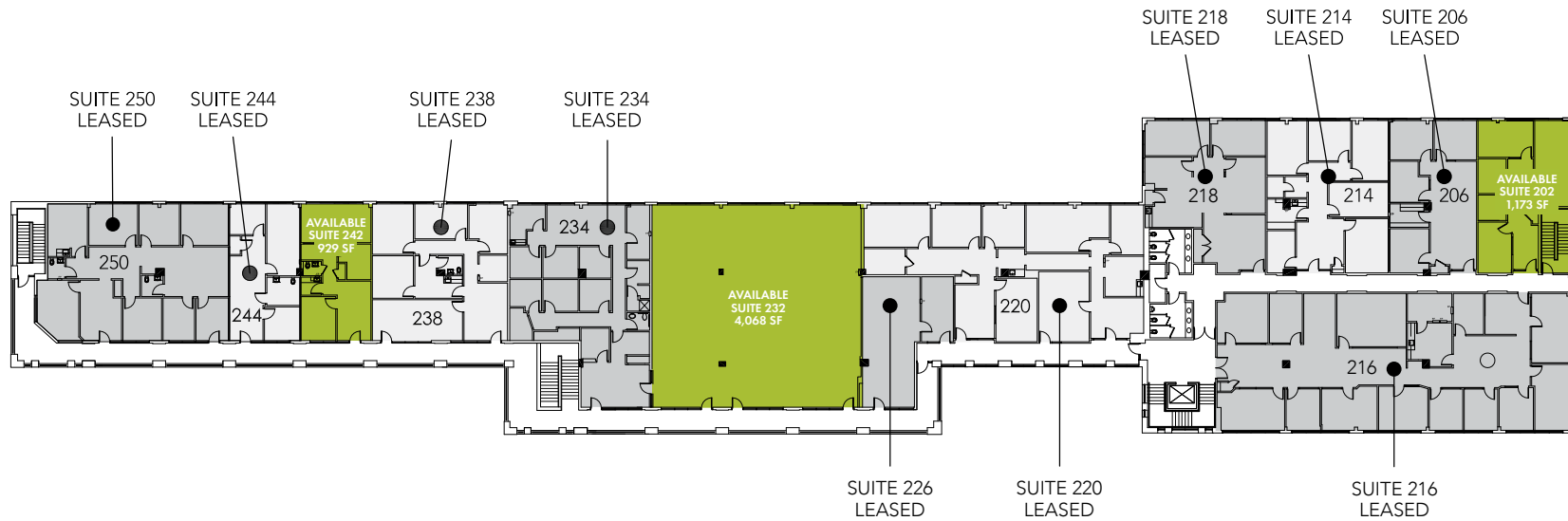

SECOND FLOOR PLAN

FLOOR PLANS - BUILDING 2

Two Greenville Crossing

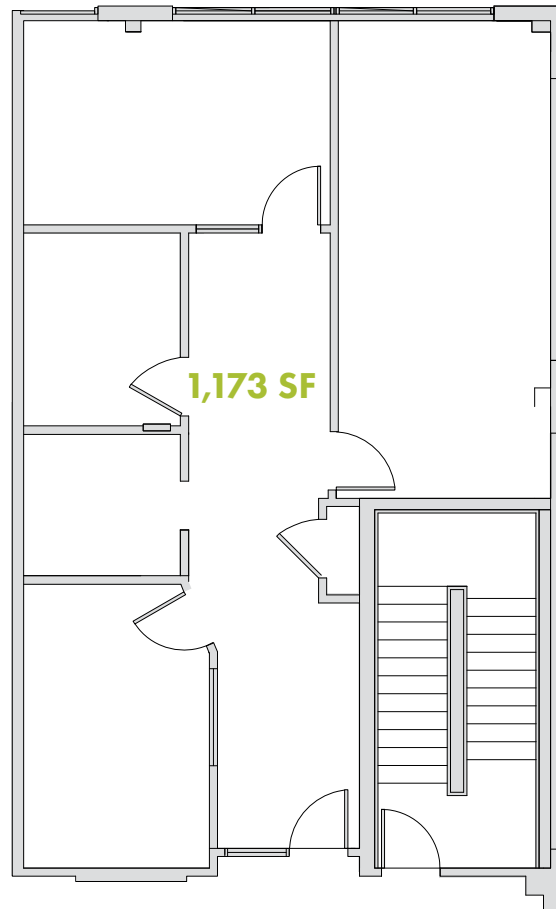

SUITE 202 • 1,173 SF

FLOOR PLANS - BUILDING 2

Two Greenville Crossing

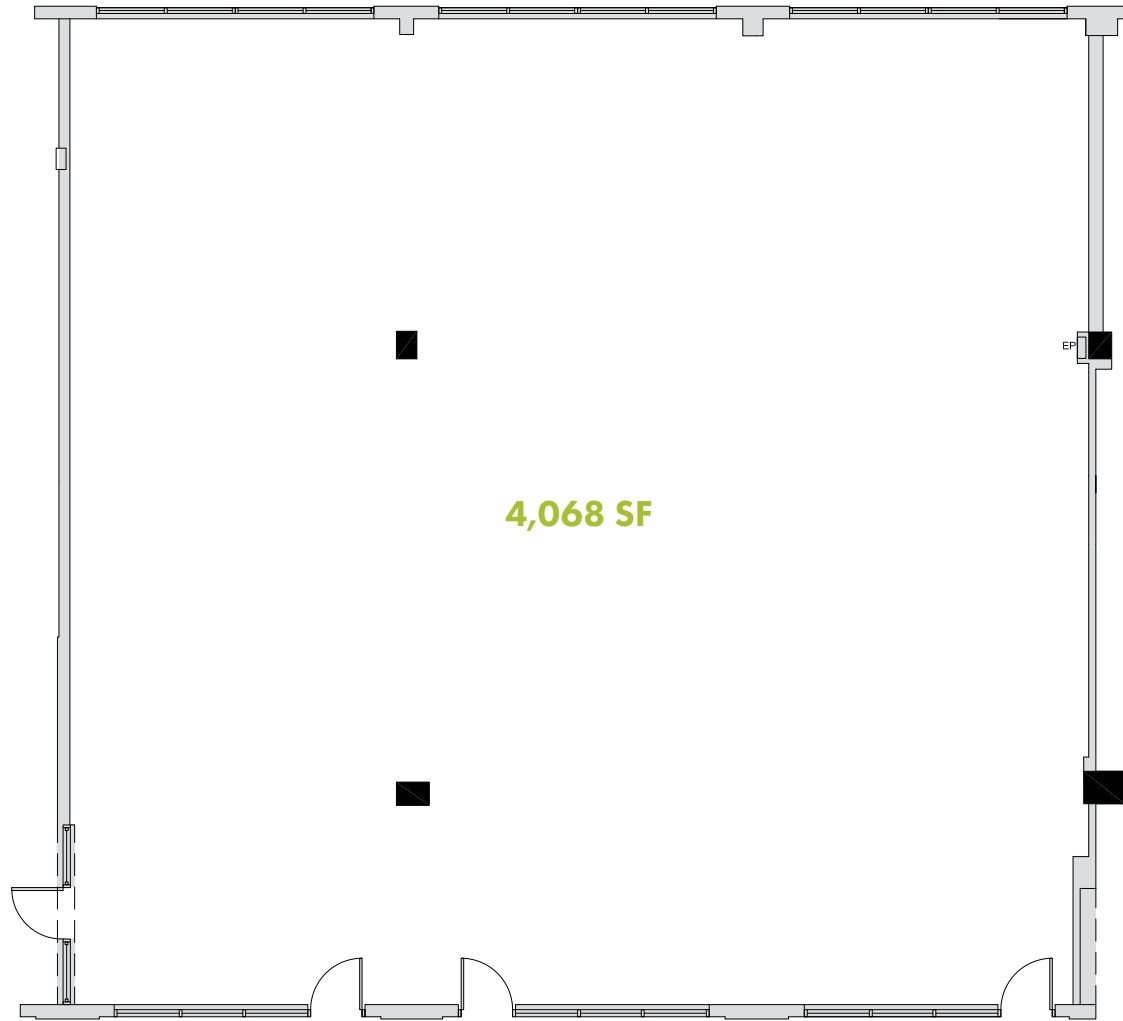

SUITE 232 • 4,068 SF

FLOOR PLANS - BUILDING 2

Two Greenville Crossing

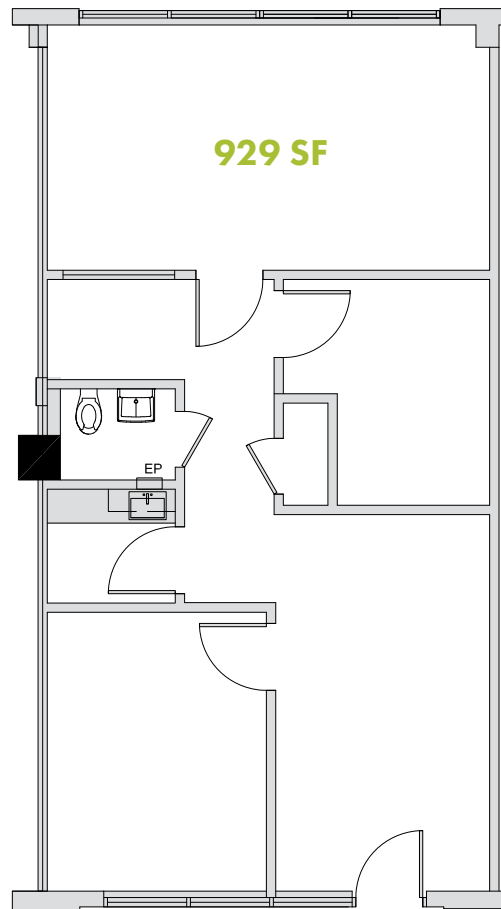

SUITE 242 • 929 SF

Jeffrey Gannett

W 302.691.4067

C 484.431.3530

F 302.601.2099

E jgannett@virtusREA.com