

55 ROMNEY STREET – Unit C

Charleston, SC

RETAIL SPACE FOR LEASE



Highlights

Available Space: Ground Floor Retail –

Suite A = 787 SF

Suite A1 = 515 SF

- Tenant Improvement Allowance: to be determined
- Zoning: UP, Upper Peninsula in the City of Charleston
- Expenses: Estimated CAM \$10.00/SF + Utilities
- Lease Rate: \$36.00 NNN

For more information, contact :

Buddy Bebergal 843.452.0660 avronbebergal@gmail.com

Chip Warley 843.224.3277 chipwarley@gmail.com

The information contained herein has been obtained from sources deemed reliable but not warranted, guaranteed or represented as to the completeness for accuracy by Premier Properties of Charleston.

55 ROMNEY STREET – Unit C

Charleston, SC

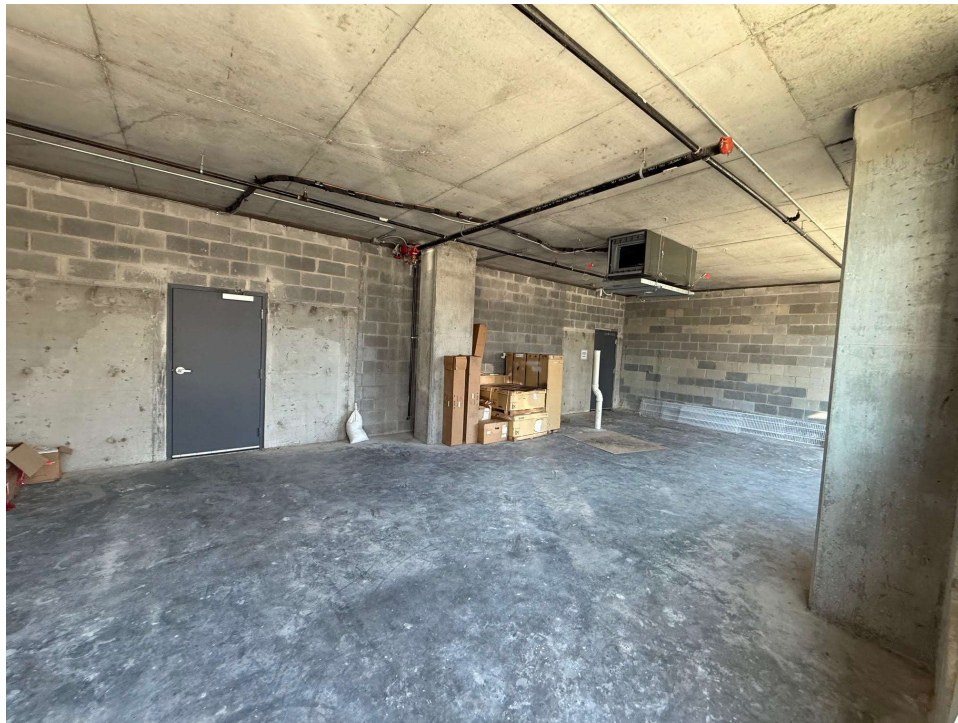
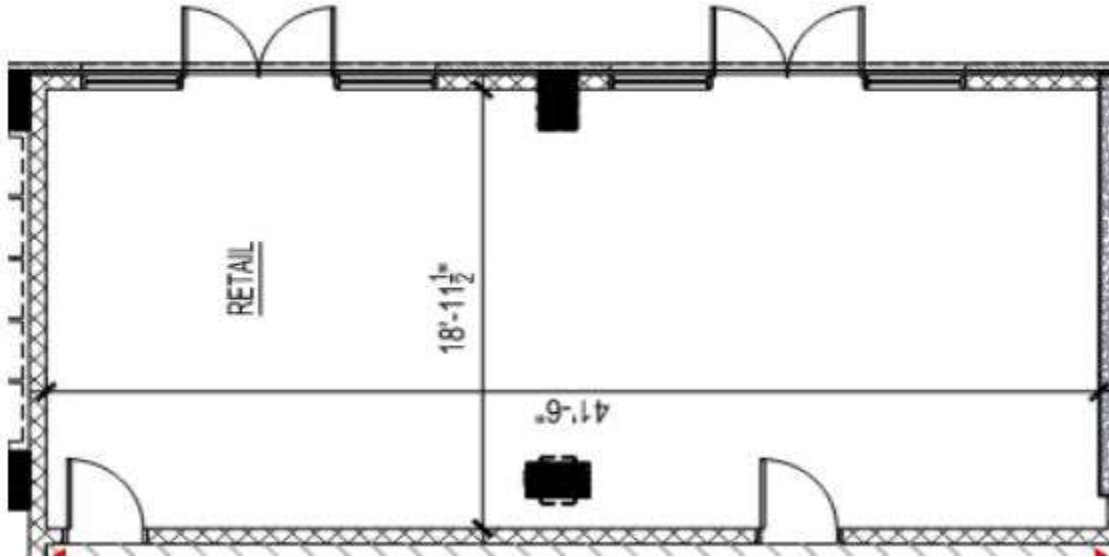

SUITE A

For more information, contact :

Buddy Bebergal 843.452.0660 avronbebergal@gmail.com

Chip Warley 843.224.3277 chipwarley@gmail.com

The information contained herein has been obtained from sources deemed reliable but not warranted, guaranteed or represented as to the completeness for accuracy by Premier Properties of Charleston.

55 ROMNEY STREET – Unit C

Charleston, SC

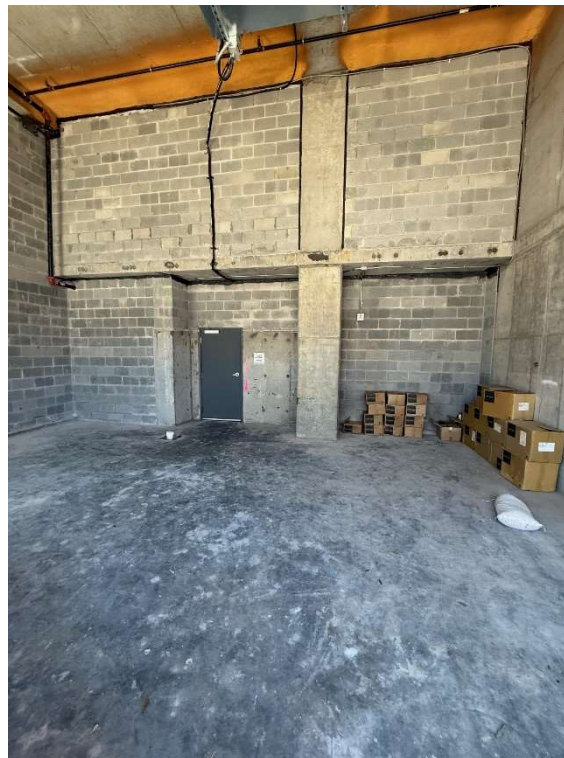
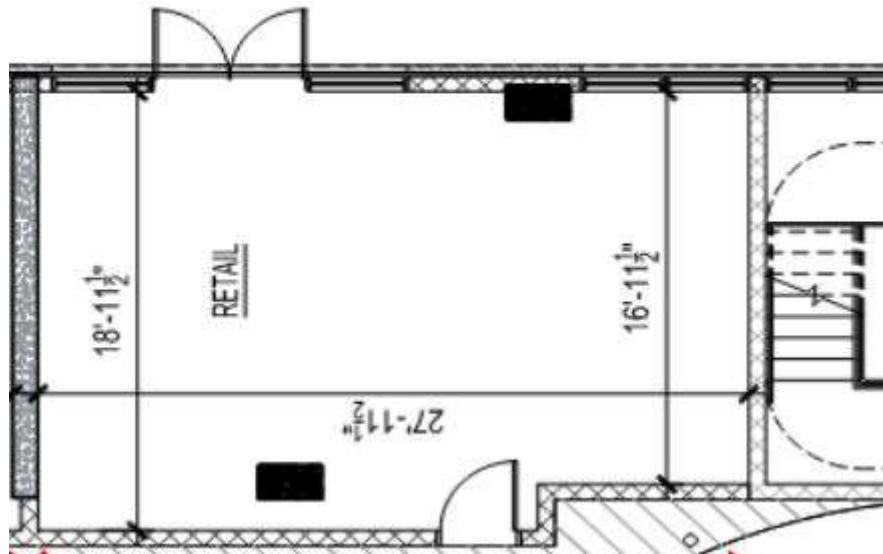

SUITE A-1

For more information, contact :

Buddy Bebergal 843.452.0660 avronbebergal@gmail.com

Chip Warley 843.224.3277 chipwarley@gmail.com

The information contained herein has been obtained from sources deemed reliable but not warranted, guaranteed or represented as to the completeness for accuracy by Premier Properties of Charleston.

55 ROMNEY STREET – Unit C

Charleston, SC



THE BUILDING

Ground Floor

Net Leaseable SF

Suite A	1,284 SF
Suite B	1,367 SF
Suite C	2,049 SF
Suite D	994 SF
Suite E	681 SF
Suite F	932 SF
Total	7,307 SF

Floor-to-Ceiling Height

Suite A	10' 1"
Suite B	20' 2"
Suite C	20' 2"
Suite D	20' 2"
Suite E	11' 4"
Suite F	11' 4"

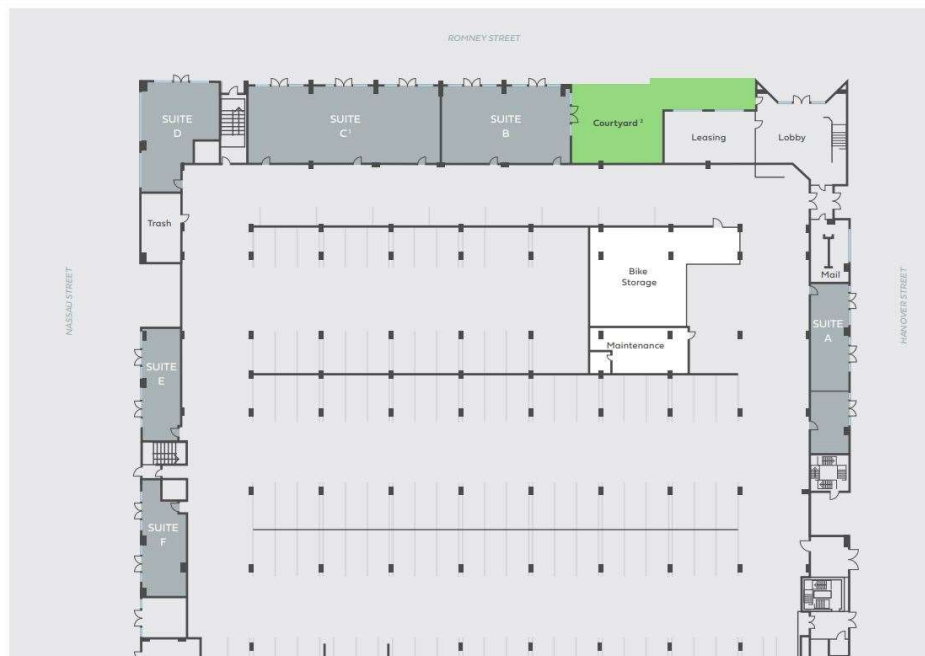

For more information, contact :

Buddy Bebergal 843.452.0660 avronbebergal@gmail.com

Chip Warley 843.224.3277 chipwarley@gmail.com

The information contained herein has been obtained from sources deemed reliable but not warranted, guaranteed or represented as to the completeness for accuracy by Premier Properties of Charleston.

