

FOR LEASE

3811 Rogers Avenue
Fort Smith, AR 72903



Executive office building consisting of two stories, no elevator. Located on Rogers Avenue, one mile from Central Mall and 1.7 miles from Interstate 540.

Suite A

Large office with 2,600 square feet on upper level. Space previously used as medical office but offers a wide variety of uses in the office sector. Suite offers waiting room/reception area, multiple offices, co-working space, plenty of storage, and private bathrooms. Lease rate is \$3,000 per month and includes all utilities.

Suite C

Office with 1,530 square feet on lower level. Space contains 5 offices and a break room. Building offers plenty of parking. Lease price is \$1,785 per month, utilities paid, except phone/wifi. Lease term 3-5 years.

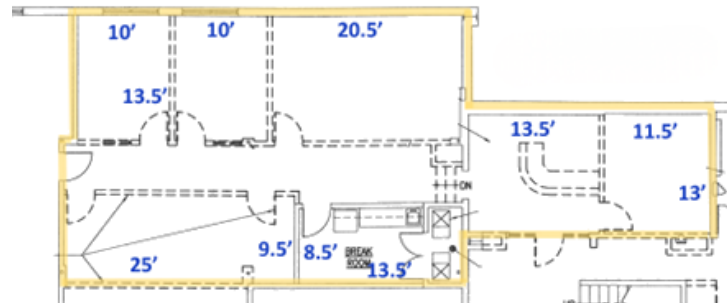

SEITER & WRIGHT
COMMERCIAL PROPERTIES
3307 OLD GREENWOOD RD, STE A - FT SMITH, AR

Jackson Mendenhall, CCIM
Associate Broker
jackson@seiterwright.com

Jerry Seiter
Principal Broker
jerry@seiterwright.com

479-785-4343
seiterwright.com