

# THE RESERVE

VICTORIA, MN

**RETAIL SPACE AVAILABLE**



# CONCEPT



*The Reserve will be a new, mixed-use development that highlights the architecture and charm of Victoria which is experiencing impressive growth.*

*The mix of high-end residential, retail, and public space will offer relaxation, convenience, and entertainment only 30 minutes from the Twin Cities.*

## TIMELINE:

- **December 2025** - Began horizontal construction and site work
- **February 2026** - Received final approval!
- **Summer 2026** - Restaurant and retail shells ready, parking established
- **2026-2029** - Phased construction of 225 units of luxury condos, townhomes, and apartments



# SITE INFORMATION



## ADDRESS

75204 Victoria Dr. Victoria, MN 55386

## AVAILABILITY

Retail and restaurant space ranging from 1,000-6,900 sq ft

## ACCESS & VISIBILITY

Excellent to highway 5 & highway 11

## FEATURES

- 12,000 sq ft plaza for use year round
- Mix of residential and retail space
- Public parking (surface level)
- 200+ parking stalls
- Pedestrian/bike trail connections to several parks and lakes

## RESIDENTIAL SPACES

- The Reserve: 225 units (118 condo, 107 luxury apartments)
- Immediate area: 354 luxury apartments
- Approved single-family housing: 1,564

**MONARCH**  
DEVELOPMENT PARTNERS



# DEMOGRAPHICS

## Population (2025)

- 1 mile: 2,592
- 3 mile: 18,882
- 5 mile: 52,859

## Daytime Employees (2025)

- 1 mile: 500
- 3 mile: 2,000
- 5 mile: 13,500

## Traffic Volume (2025)

- Highway 5: 14,407
- Highway 11: 4,104

## Avg Income (3 miles, 2025 est.)

- \$226,859

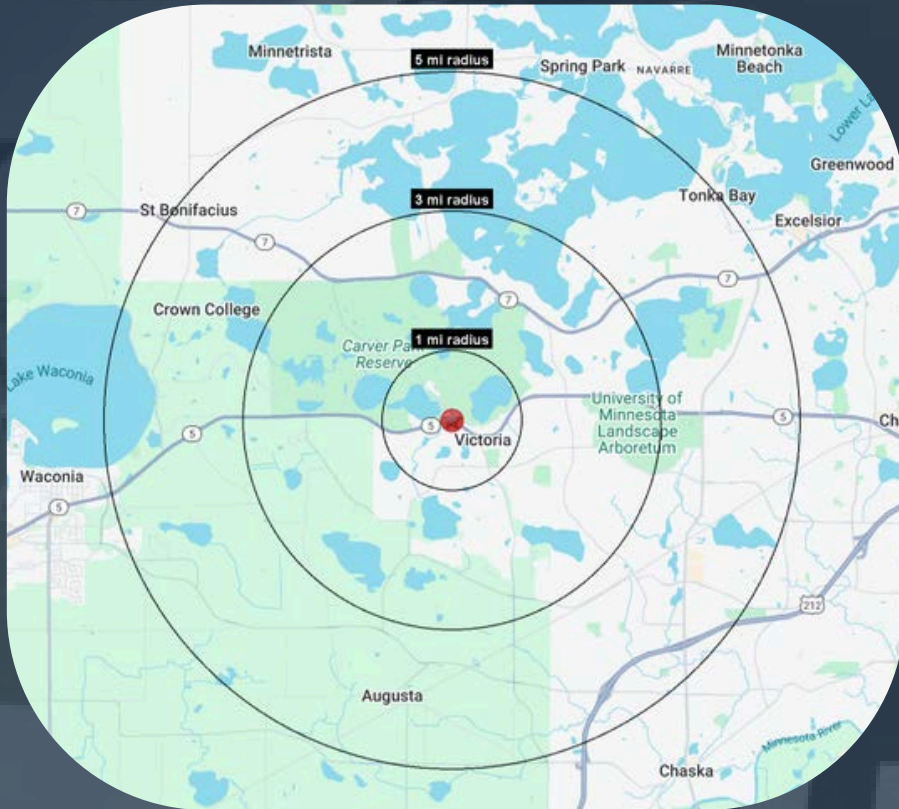
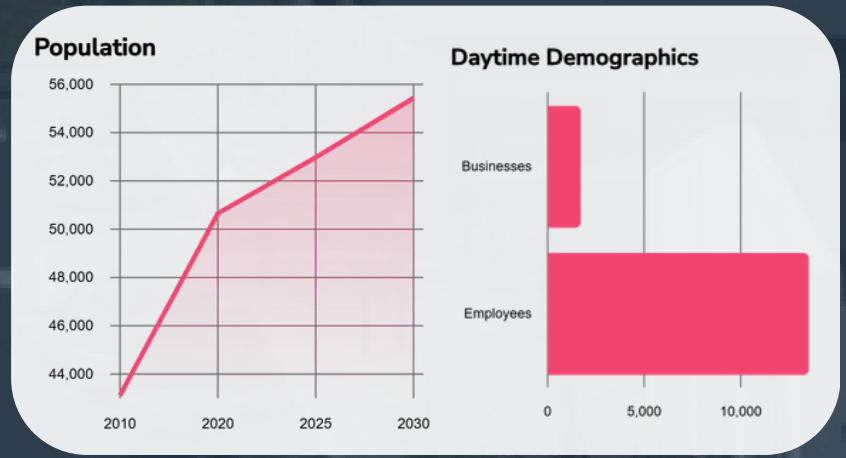

# LOCAL RETAILERS



Floyd's Bar

Janie's Tacos



snap fitness 24/7



Vics Bar & Grill



# AREA RETAIL

Carver Park Reserve

CHANHASSEN

SITE

WAGONIA

1/2 mile

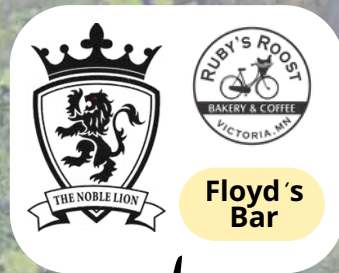

Floyd's Bar

snap fitness 24/7

OMNI  
Brewery & Taproom  
VICTORIA

Vic's Bar & Grill



SUBWAY

Janie's Tacos

THE BURROW  
FOOD LIBRARY - SHENANDOAH



VICTORIA

CIRCLE K

# SITE PLAN

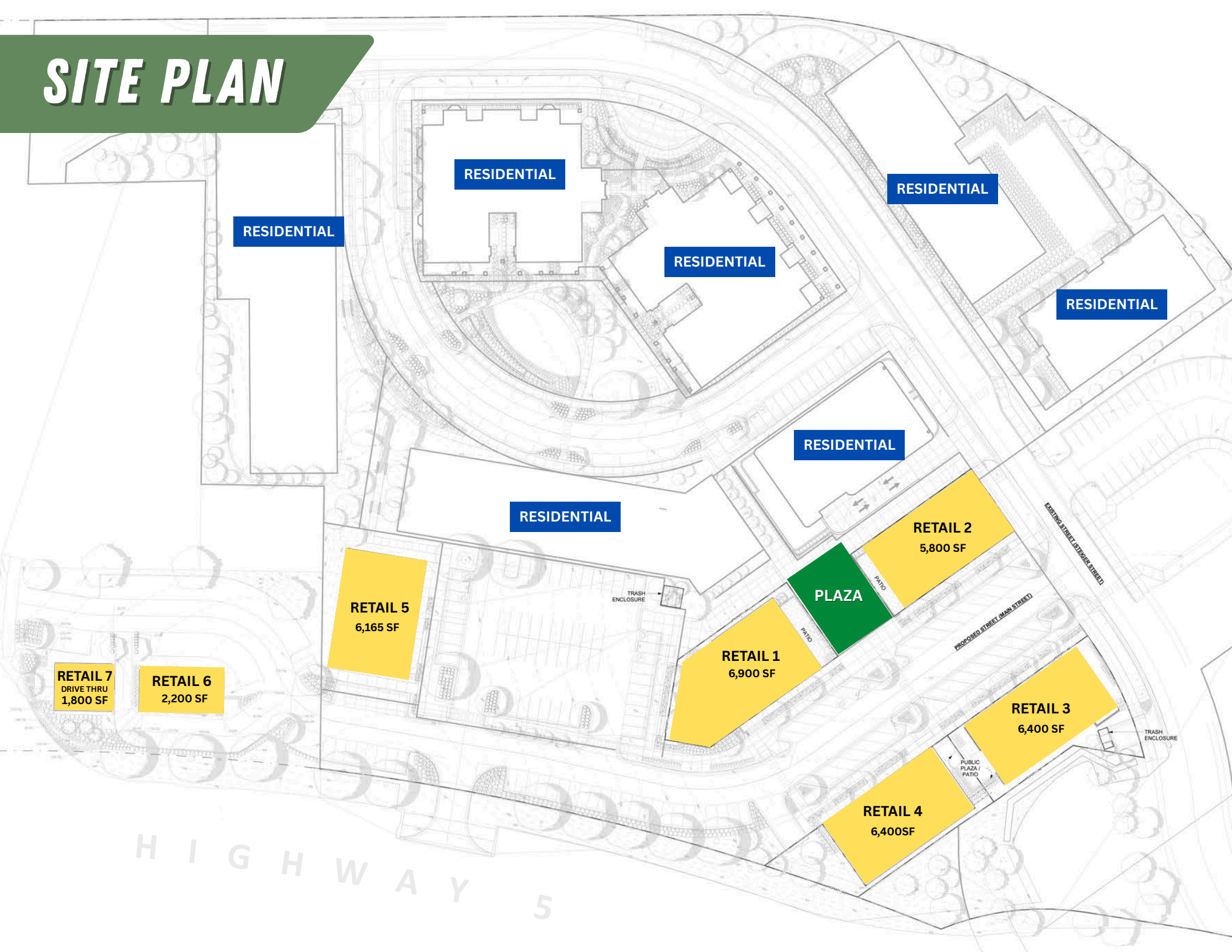

RESIDENTIAL

RESIDENTIAL

RESIDENTIAL

RESIDENTIAL

RESIDENTIAL

RESIDENTIAL

RESIDENTIAL

RETAIL 5  
6,165 SF

RETAIL 7  
DRIVE THRU  
1,800 SF

RETAIL 6  
2,200 SF

RETAIL 1  
6,900 SF

RETAIL 2  
5,800 SF

PLAZA

RETAIL 4  
6,400SF

PROPOSED STREET (MAIN STREET)

EXISTING STREET (LEWIS STREET)

PUBLIC PLAZA / PATIO

RETAIL 3  
6,400 SF

H I G H W A Y 5

# RETAIL SPACE

*Retail buildings can be single or multi-use tenants. Layouts can be modified as desired*



**RETAIL 1**



**RETAIL 2**



# RETAIL SPACE

*Retail buildings can be single or multi-use tenants. Layouts can be modified as desired*



**RETAIL 3**

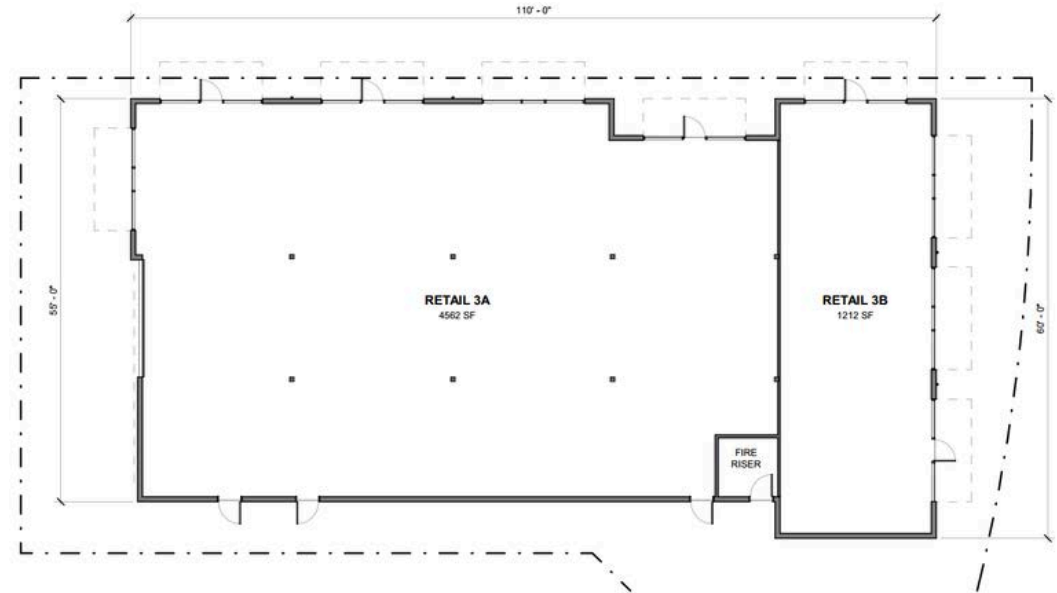

**RETAIL 4**

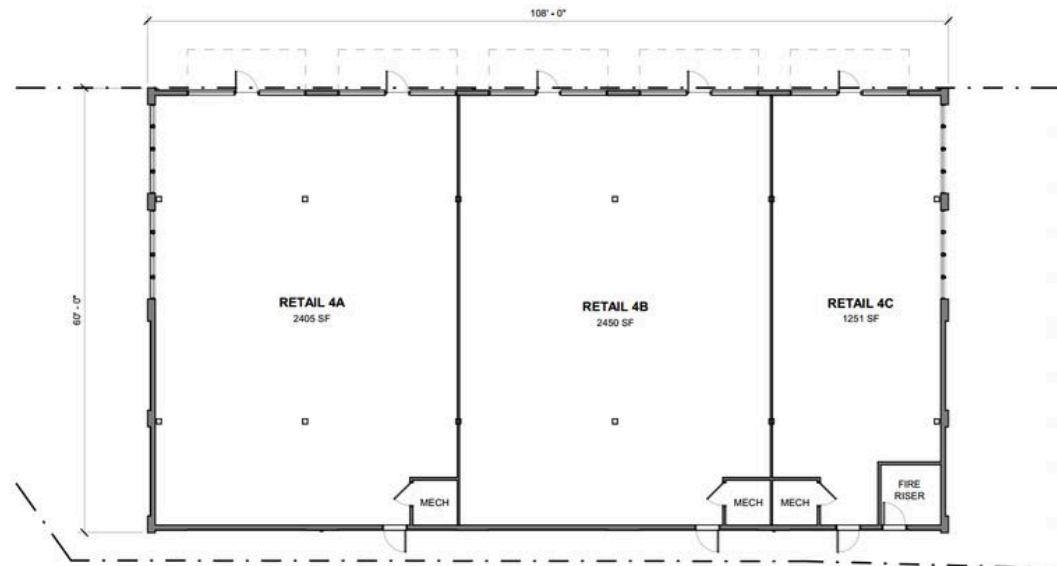

# RETAIL SPACE

*Retail buildings can be single or multi-use tenants. Layouts can be modified as desired*

**RETAIL 5**



**RETAIL 7**

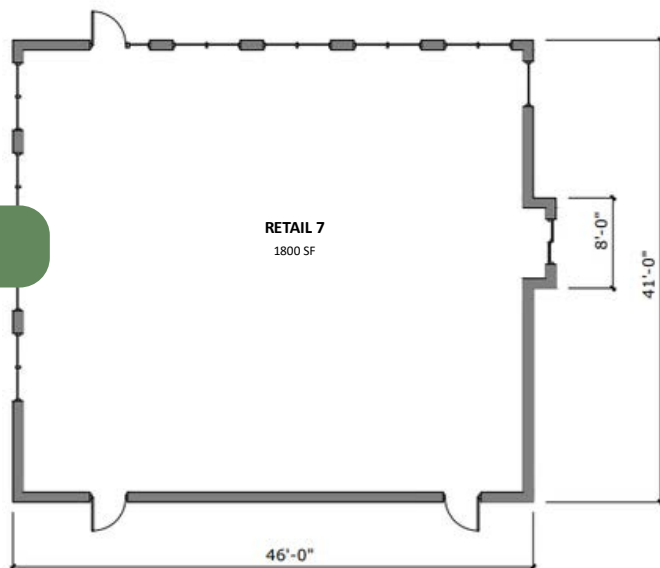

**RETAIL 6**

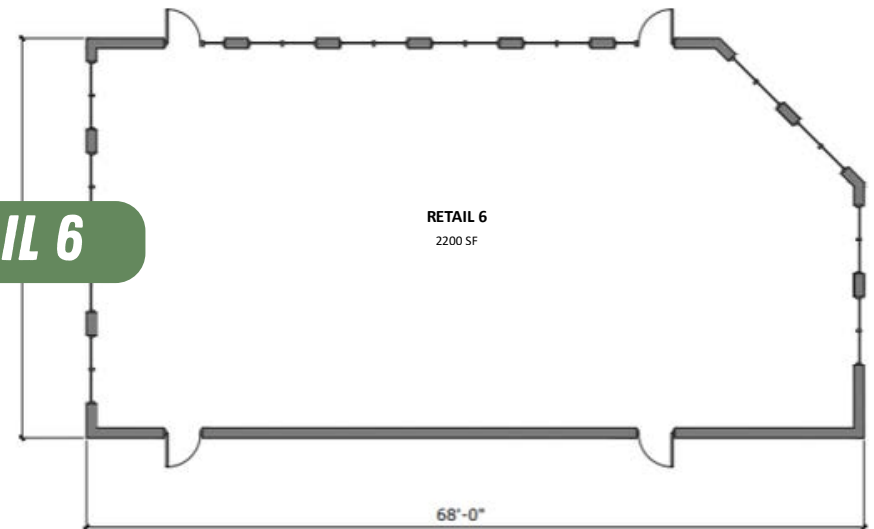



**ACTIVATED EDGE WITH  
FIXED SEATING AND DRINK  
RAIL**

**FLEXIBLE PLATFORM**

**ACTIVATED EDGE WITH  
TREES**

**FLEX LAWN FOR VARIOUS  
SCALES OF PROGRAMMING**

**FLEXIBLE SEATING**

**ACTIVATED EDGE  
WITH DRINK RAIL**

**TERRACED SEATING**

**FUTURE ACTIVATION ZONE  
(TO BE DESIGNED IN  
COLLABORATION WITH  
CITY)**

# **PLAZA CONCEPT**

***CONTACT US***

**Russ McGinty**

612-619-9611

[russ@nccreatestate.com](mailto:russ@nccreatestate.com)

**Ed McGinty**

612-619-0804

[ed@nccreatestate.com](mailto:ed@nccreatestate.com)

