

5 BANQUET - EAST
SCALE: 1/4" = 1'-0"

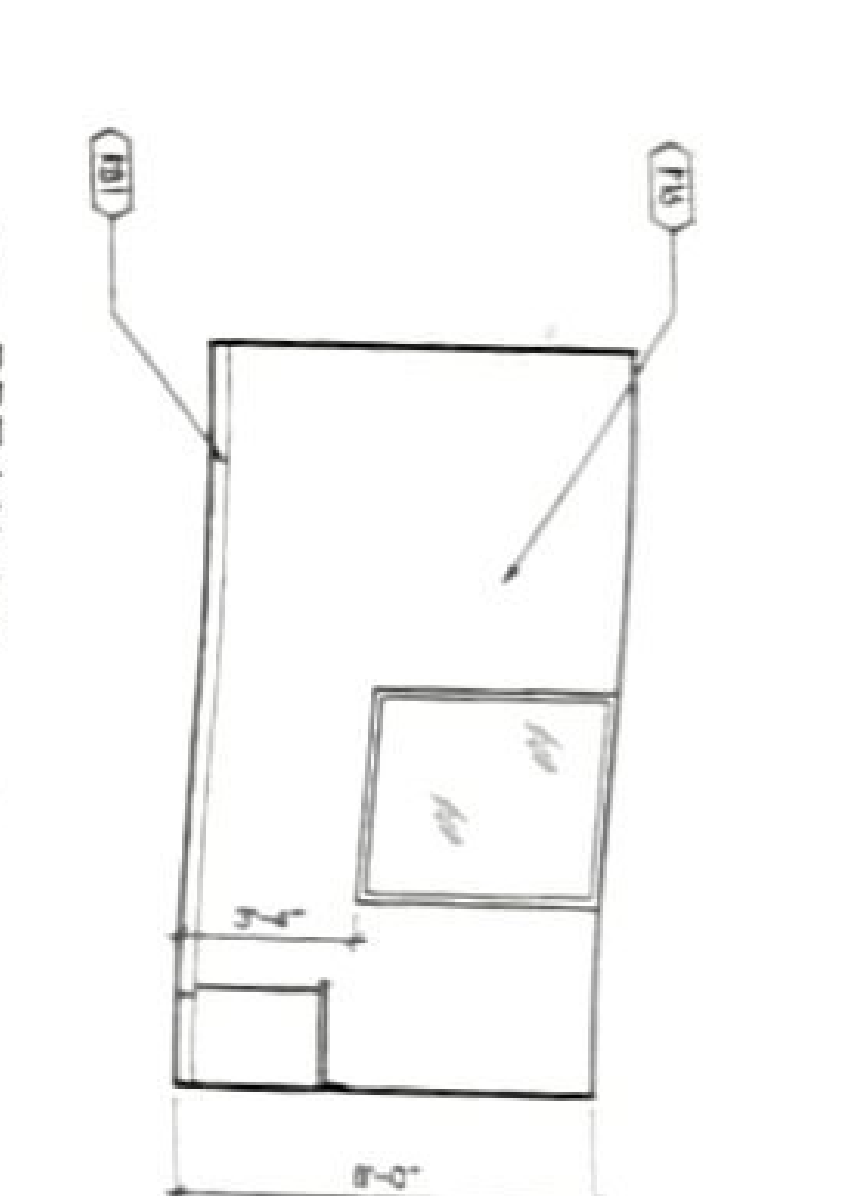

6 BANQUET - WEST
SCALE: 1/4" = 1'-0"

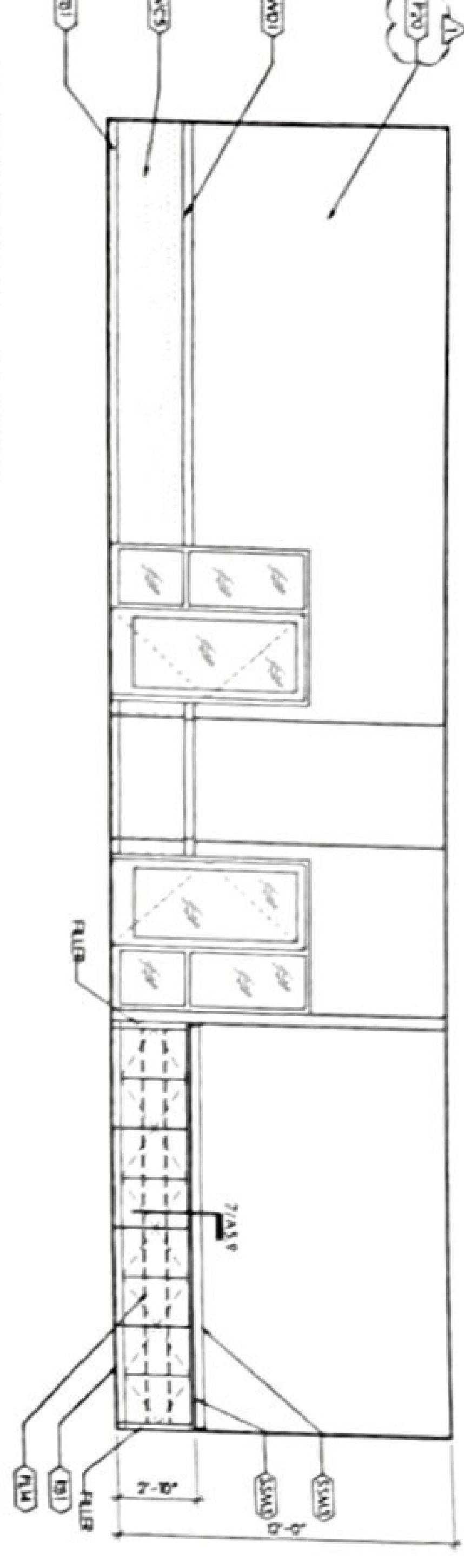

4 BANQUET - SOUTH
SCALE: 1/4" = 1'-0"

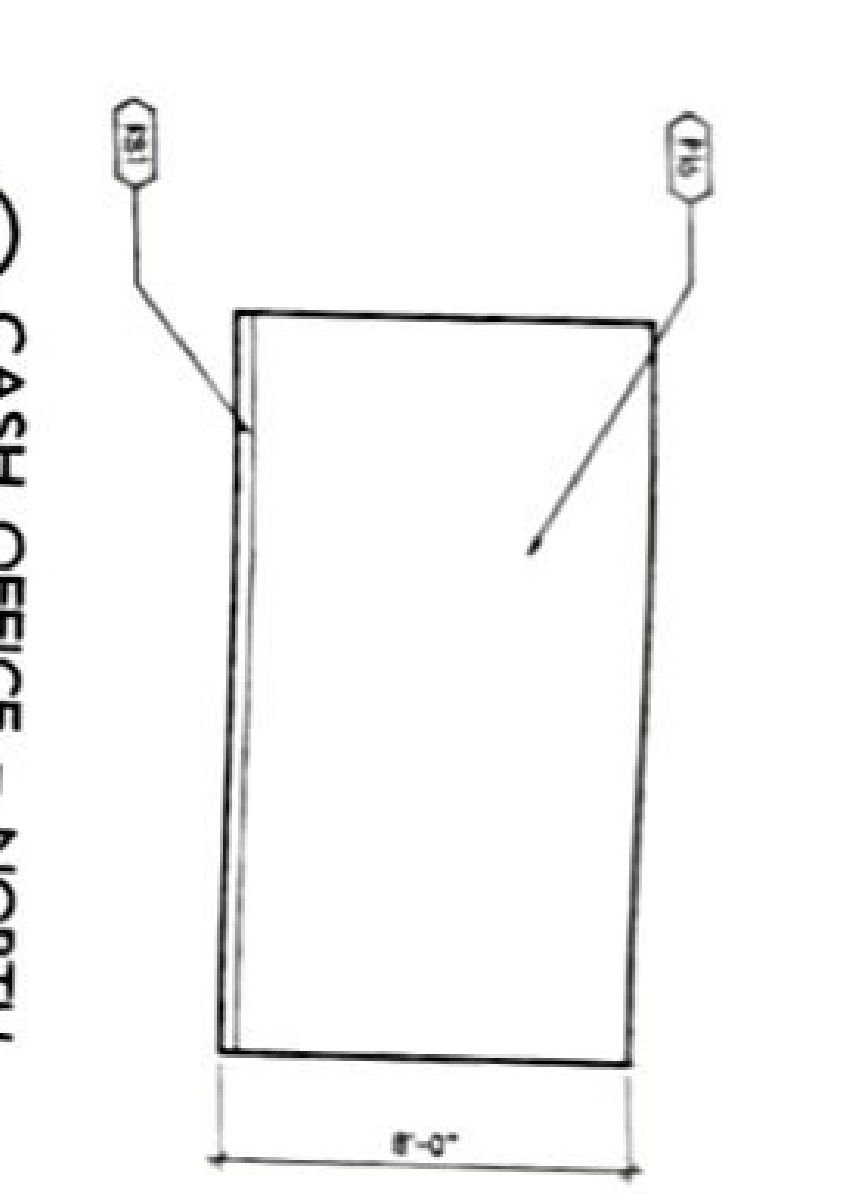

11 CASH OFFICE - NORTH
SCALE: 1/4" = 1'-0"

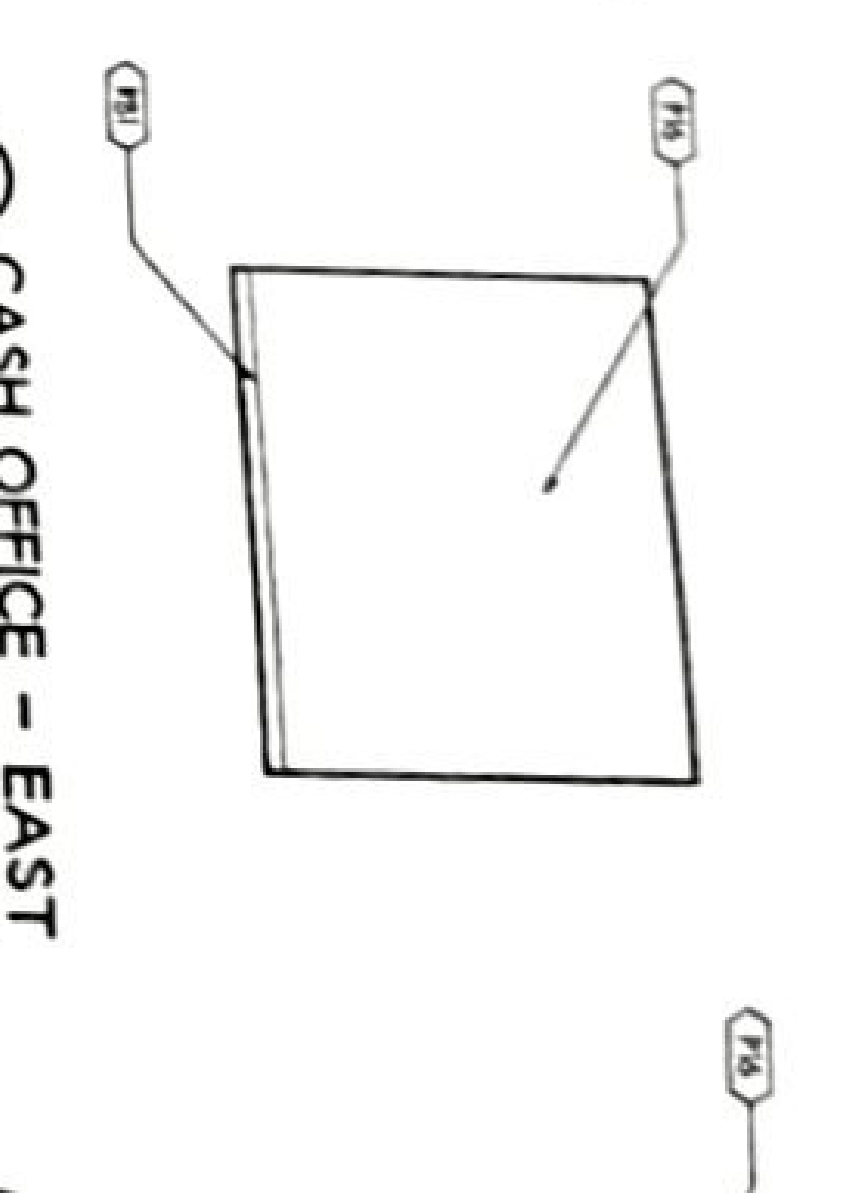

12 CASH OFFICE - EAST
SCALE: 1/4" = 1'-0"

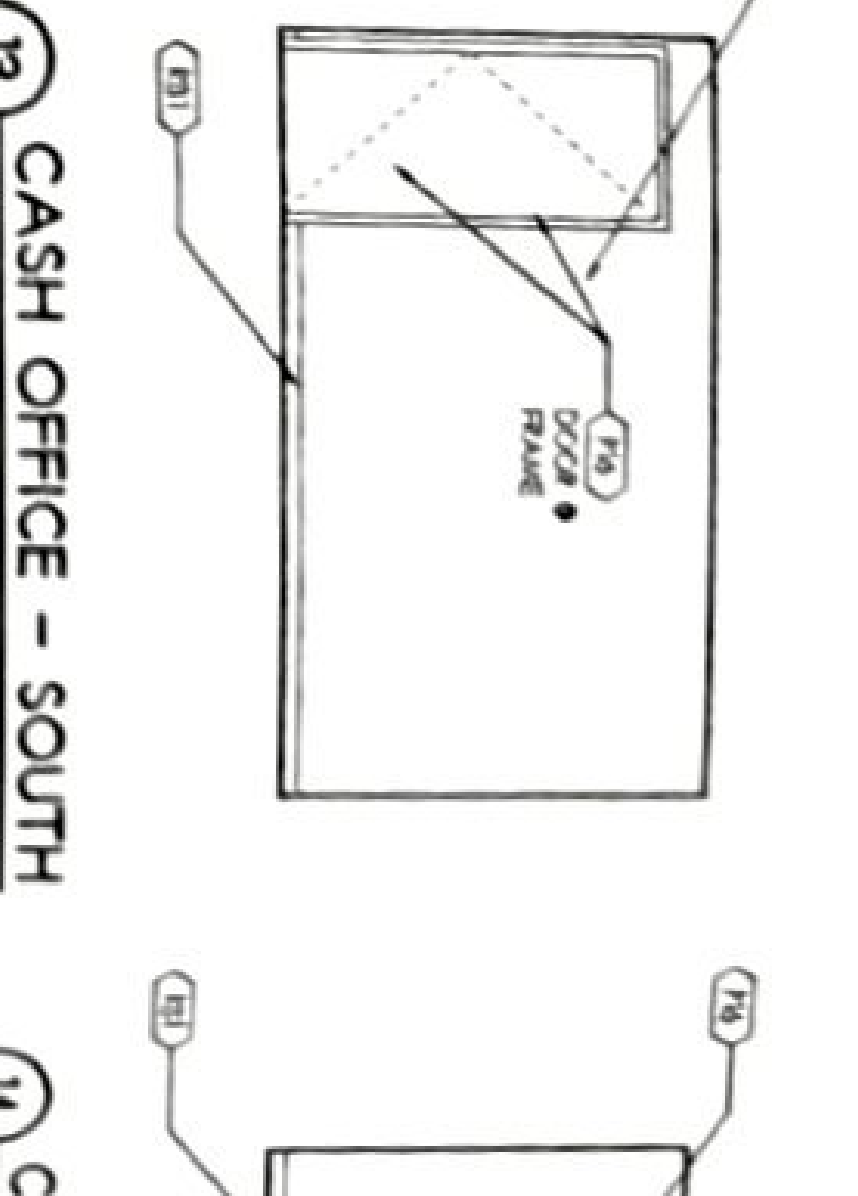

13 CASH OFFICE - SOUTH
SCALE: 1/4" = 1'-0"

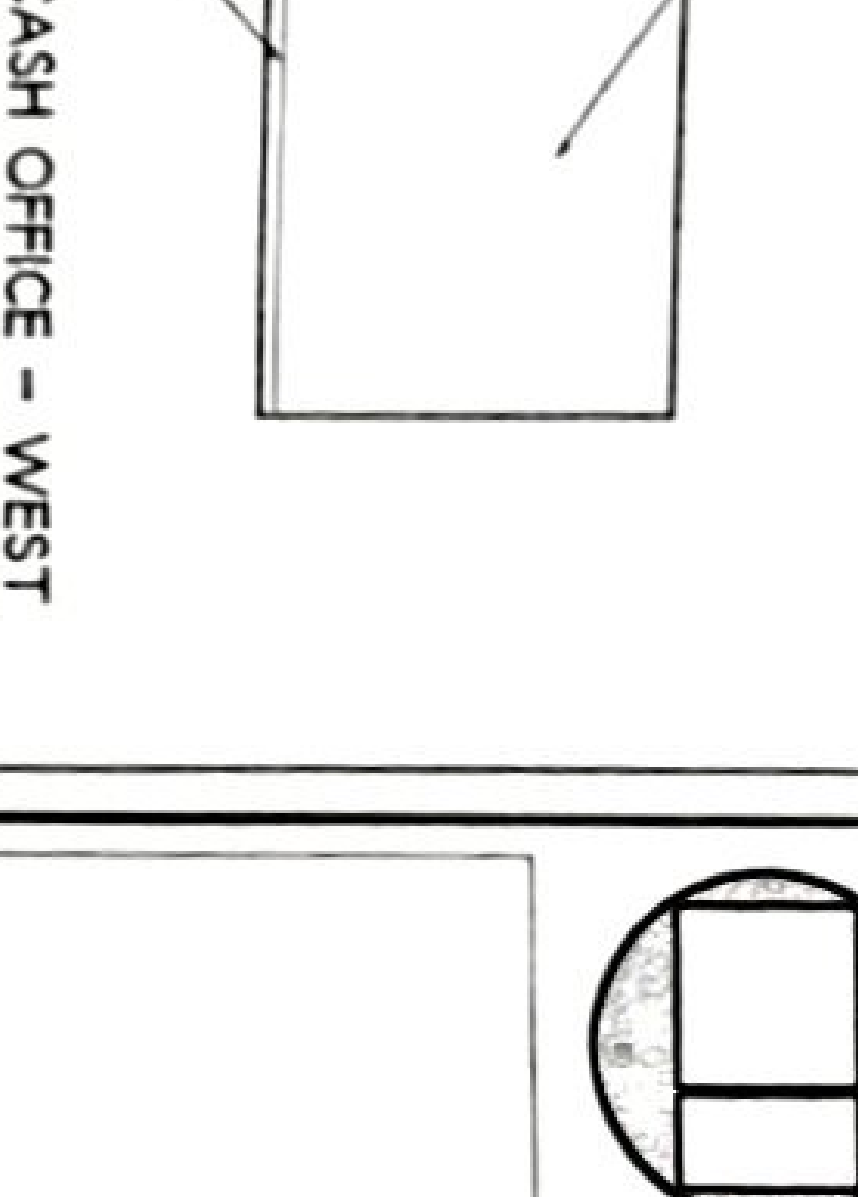

14 CASH OFFICE - WEST
SCALE: 1/4" = 1'-0"

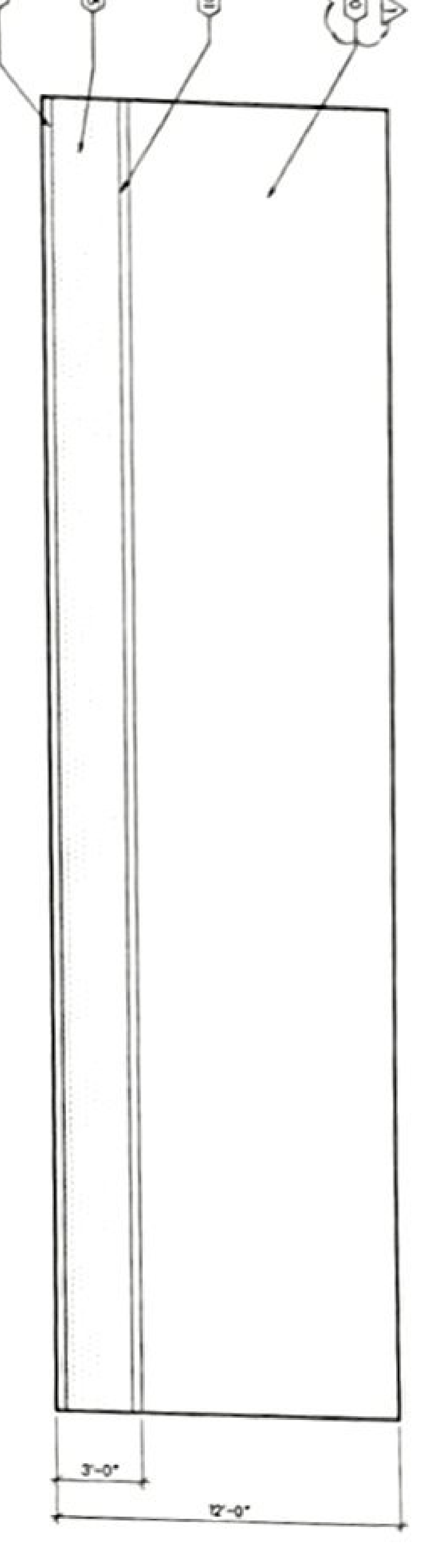

3 BANQUET - NORTH
SCALE: 1/4" = 1'-0"

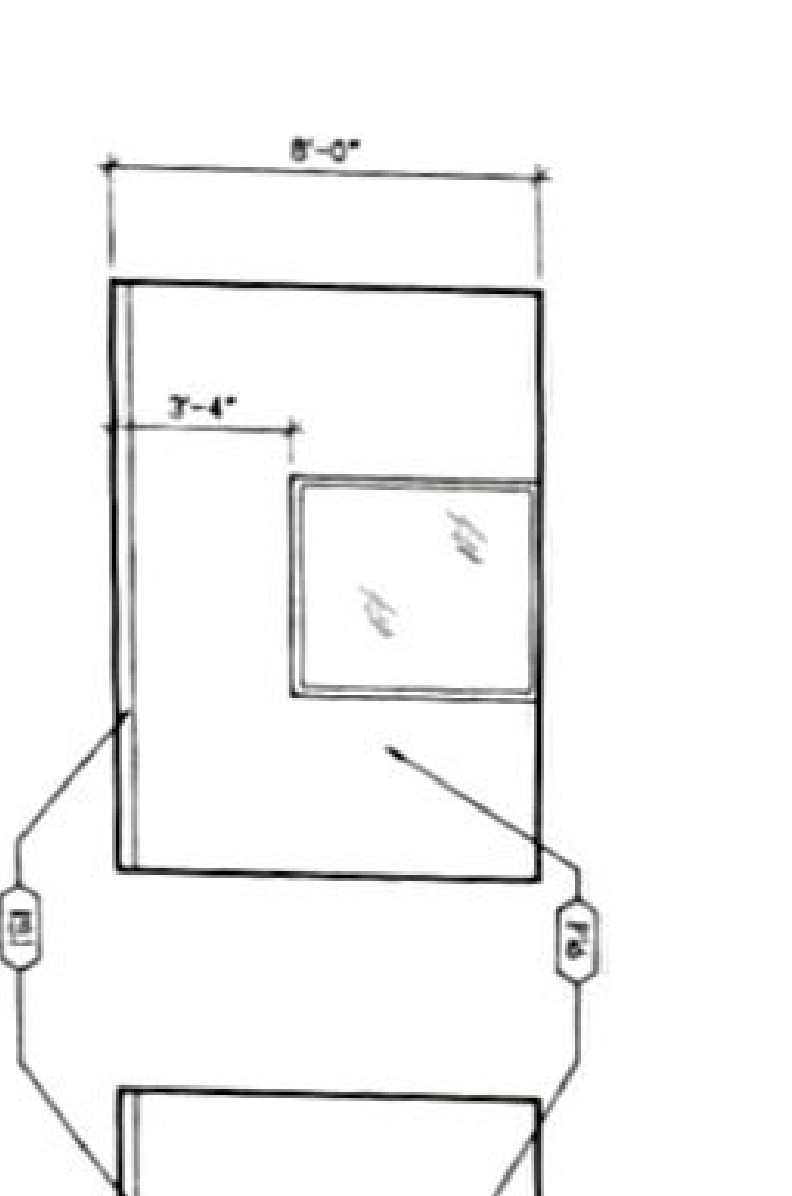

15 MGR. OFFICE - NORTH
SCALE: 1/4" = 1'-0"

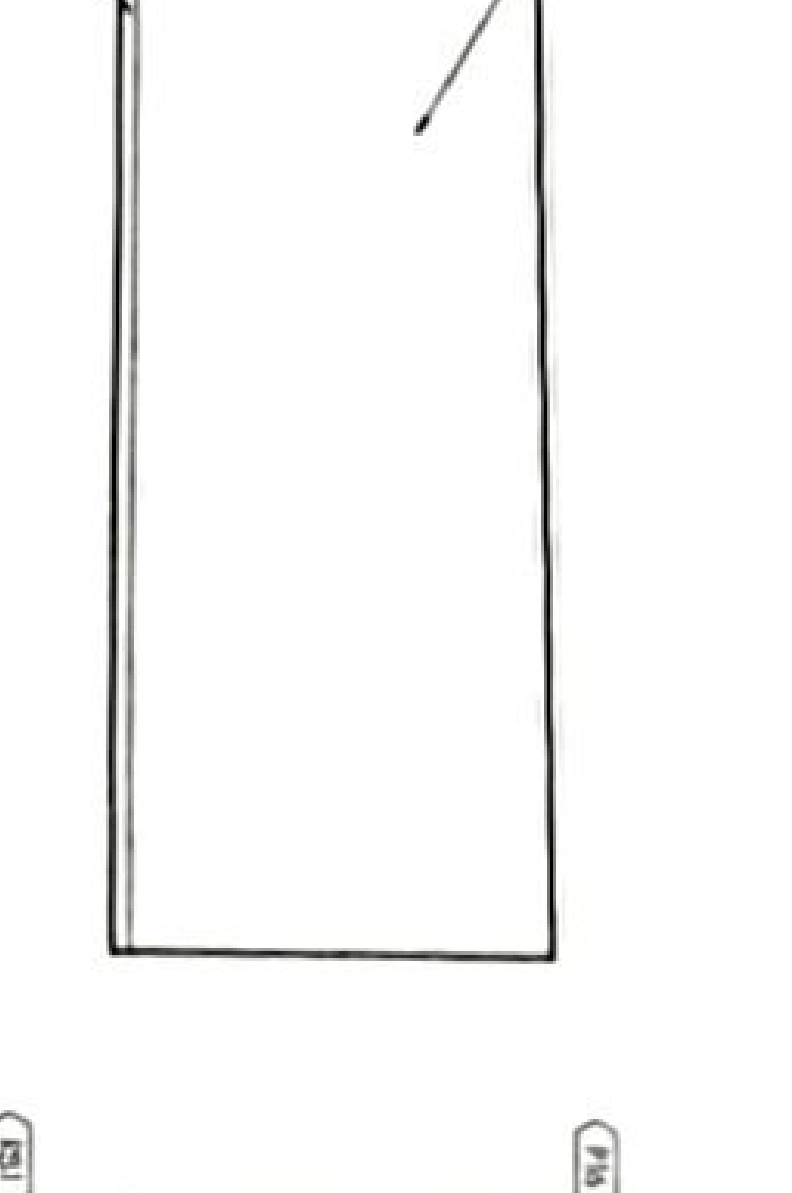

16 MGR. OFFICE - EAST
SCALE: 1/4" = 1'-0"

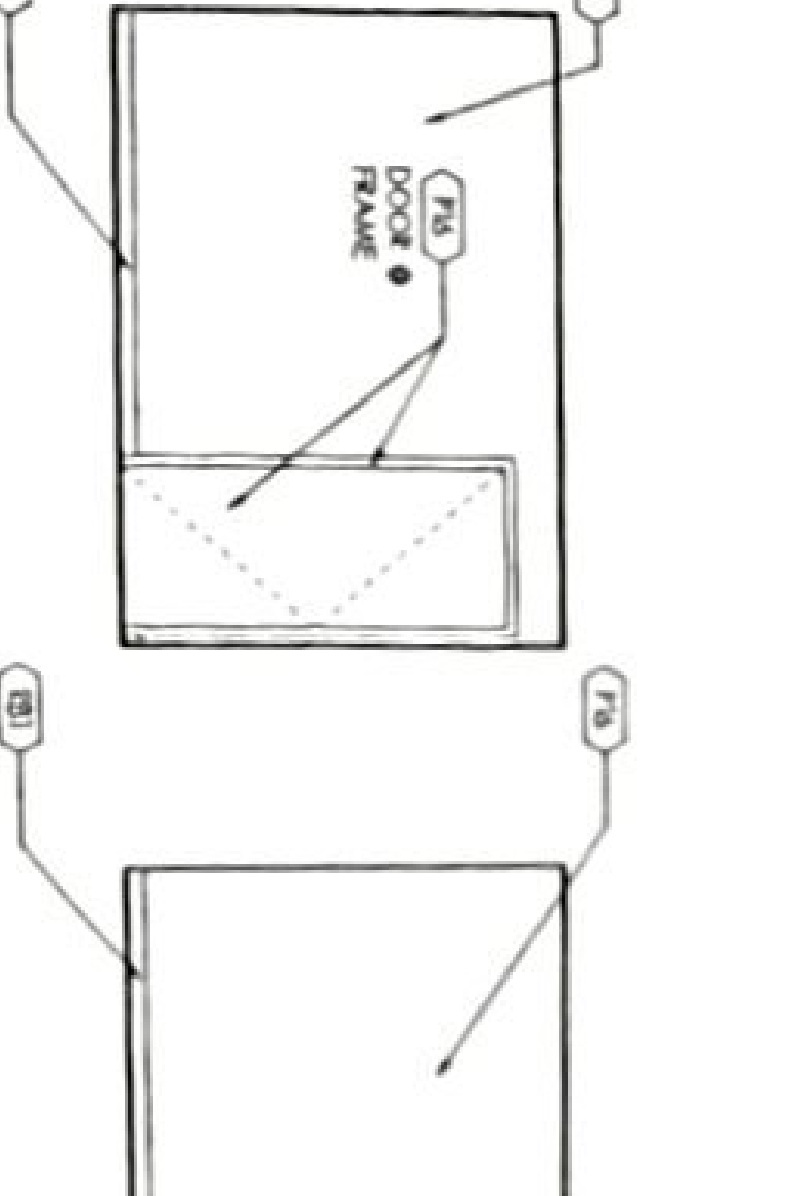

17 MGR. OFFICE - SOUTH
SCALE: 1/4" = 1'-0"

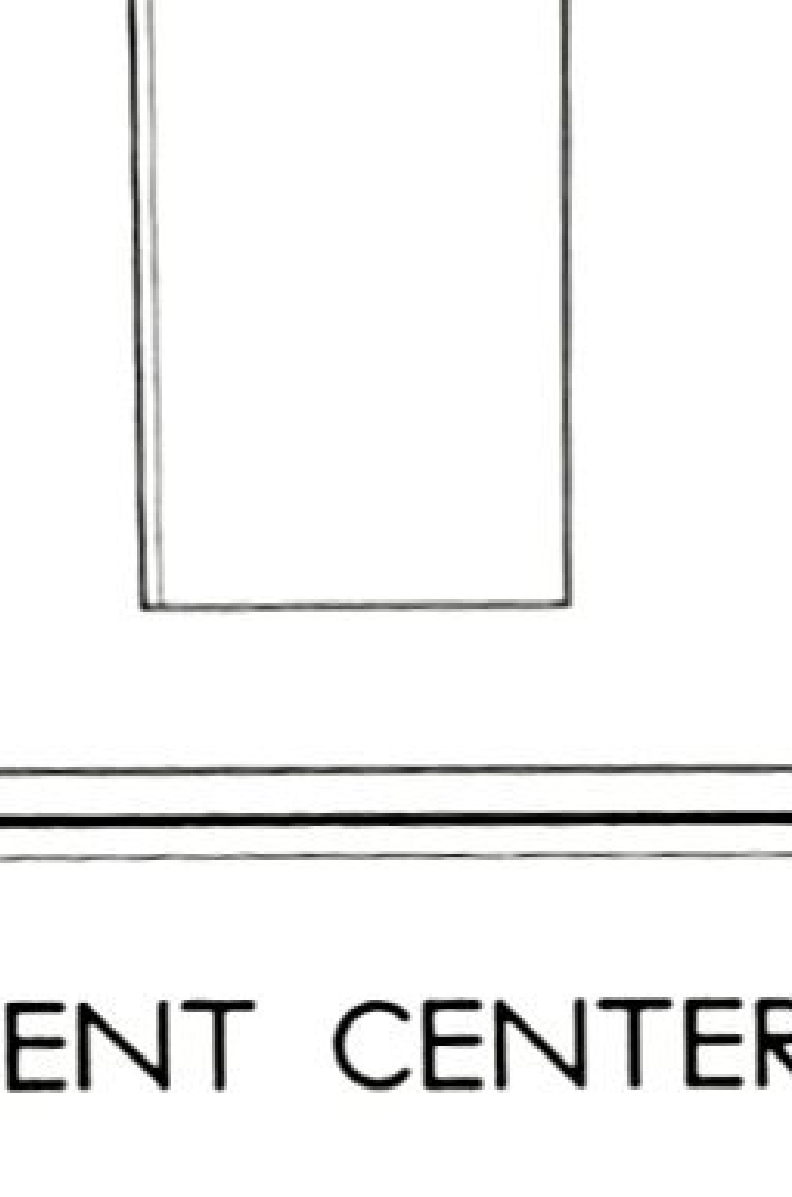

18 MGR. OFFICE - WEST
SCALE: 1/4" = 1'-0"

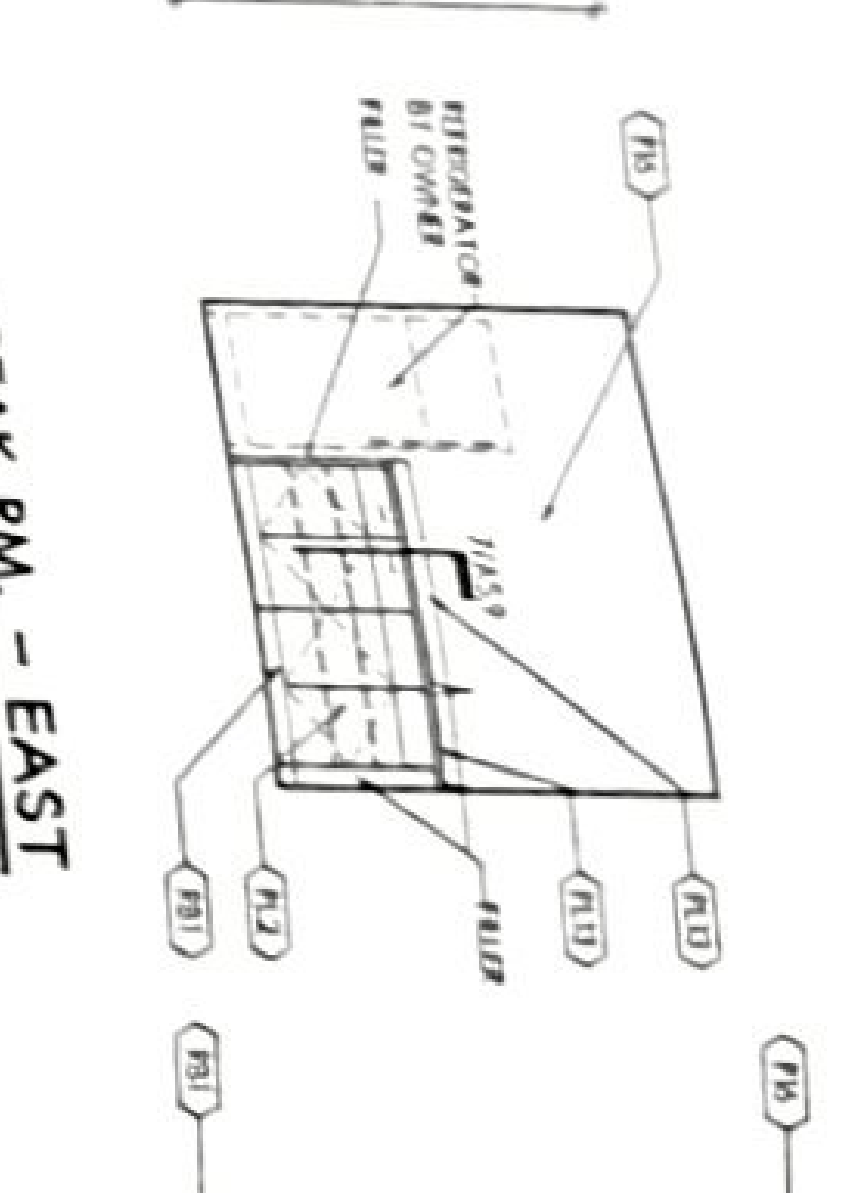

8 BREAK RM. - EAST
SCALE: 1/4" = 1'-0"

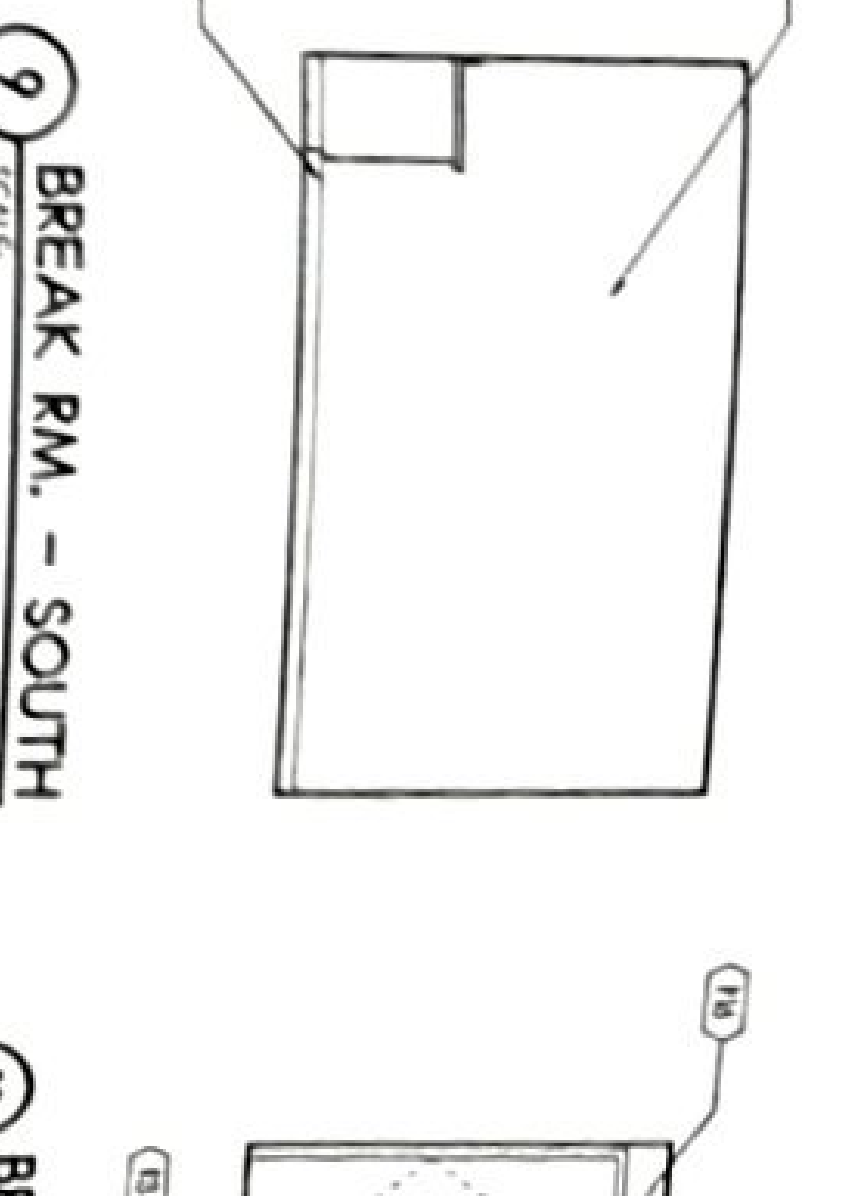

9 BREAK RM. - SOUTH
SCALE: 1/4" = 1'-0"

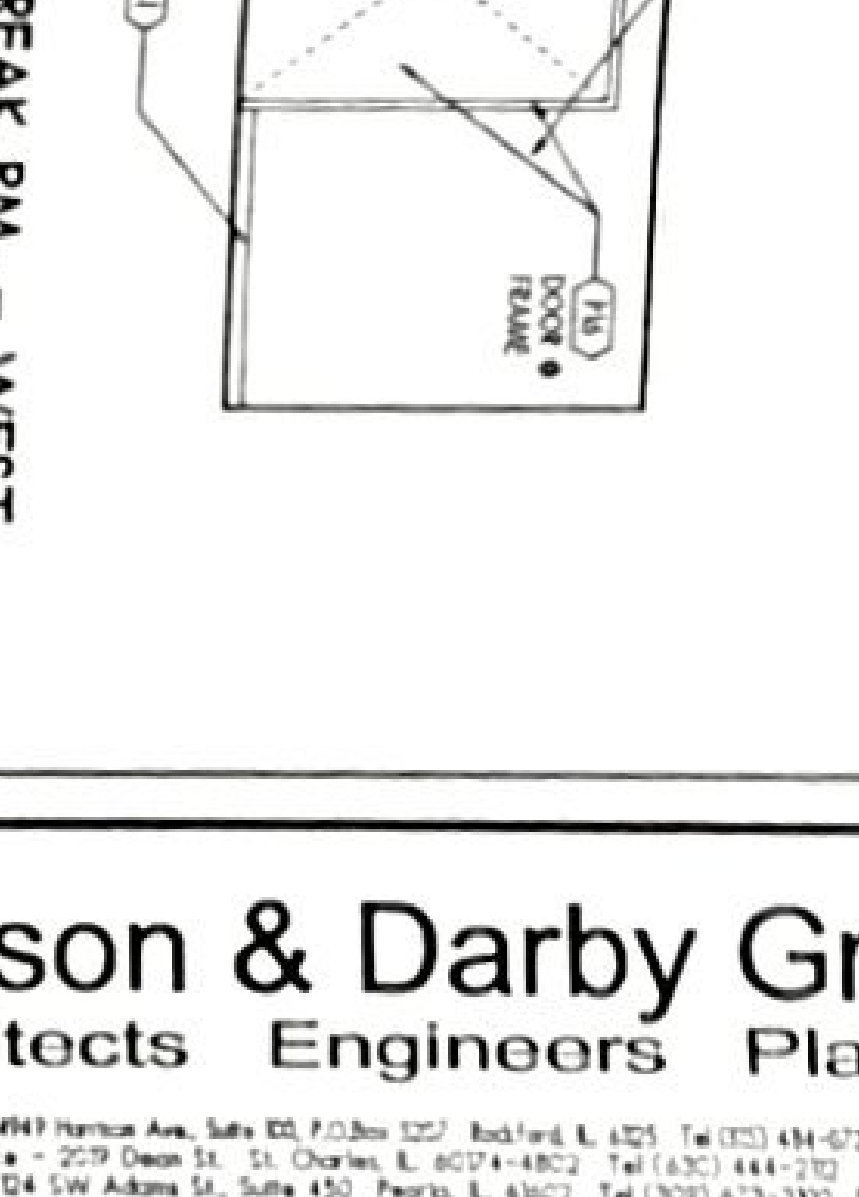

10 BREAK RM. - WEST
SCALE: 1/4" = 1'-0"

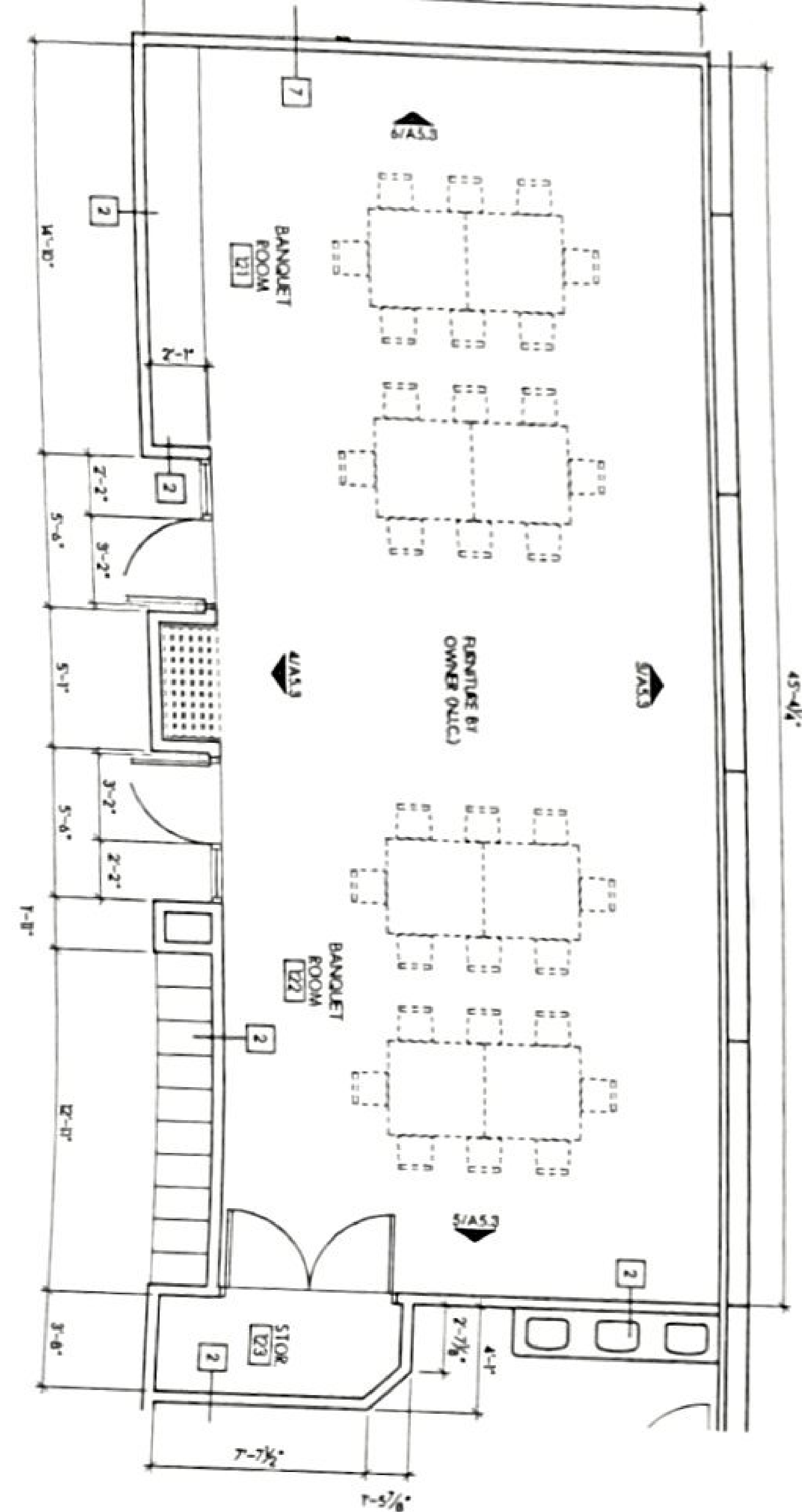

1 ENLARGED BANQUET ROOMS - 121, 122
SCALE: 1/4" = 1'-0"

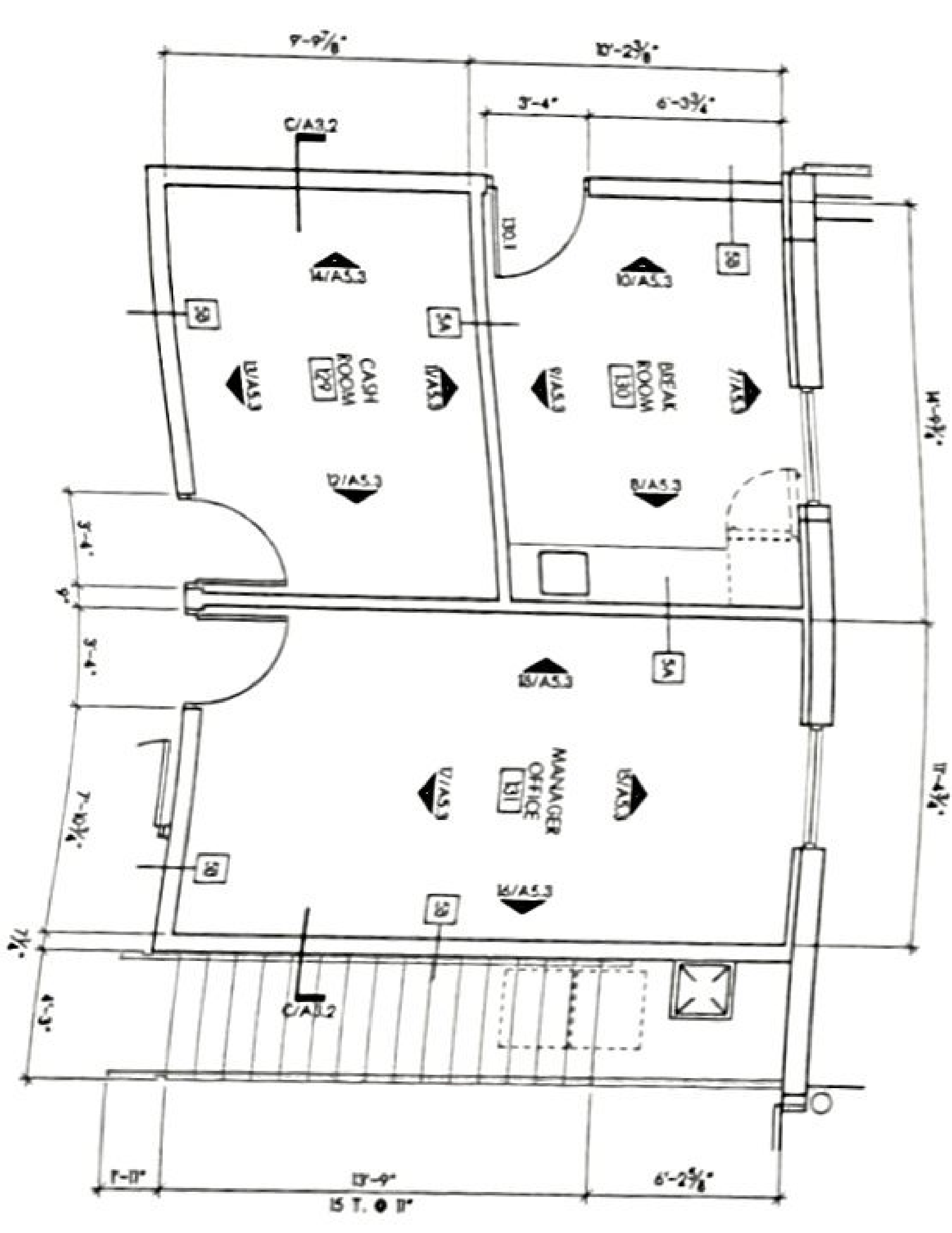

2 ENLARGED OFFICES - 129, 130, 131
SCALE: 1/4" = 1'-0"

DETAIL PLANS AND INTERIOR ELEVATIONS

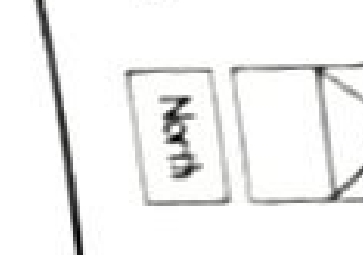

| | |
|-----------------------|---------------------------|
| DATE: 07/20/09 | ISSUED FOR: |
| PROJECT NUMBER: 18145 | NO. 22 ADDENDUM 1 CHANGES |
| SHEET NUMBER: A5.3 | NO. 22 FOR CONSTRUCTION |
| | DRAWN: JSW APPROVED: DJR |

A DESIGN FOR:
FAMILY ENTERTAINMENT CENTER
MARENGO, ILLINOIS

Larson & Darby Group
Architects Engineers Planners

Rockford Office - 489 Riverside Ave., Suite 202, Rockford, IL 61101 Tel: (815) 398-6279 Fax: (815) 398-6840
St. Charles Office - 209 Dean St., St. Charles, IL 60144-4802 Tel: (630) 444-2102 Fax: (630) 444-2108
Peoria Office - 24 SW Adams St., Suite 450 Peoria, IL 61602 Tel: (309) 673-3800 Fax: (309) 673-3420

- GENERAL NOTES:**
1. PROVIDE ELEVATION INFORMATION (FINISH)
 2. VISIT ALL FINISH AND OPENING SCHEDULES (AS)

2 DINING AREA - NORTH
SCALE: 1/4" = 1'-0"

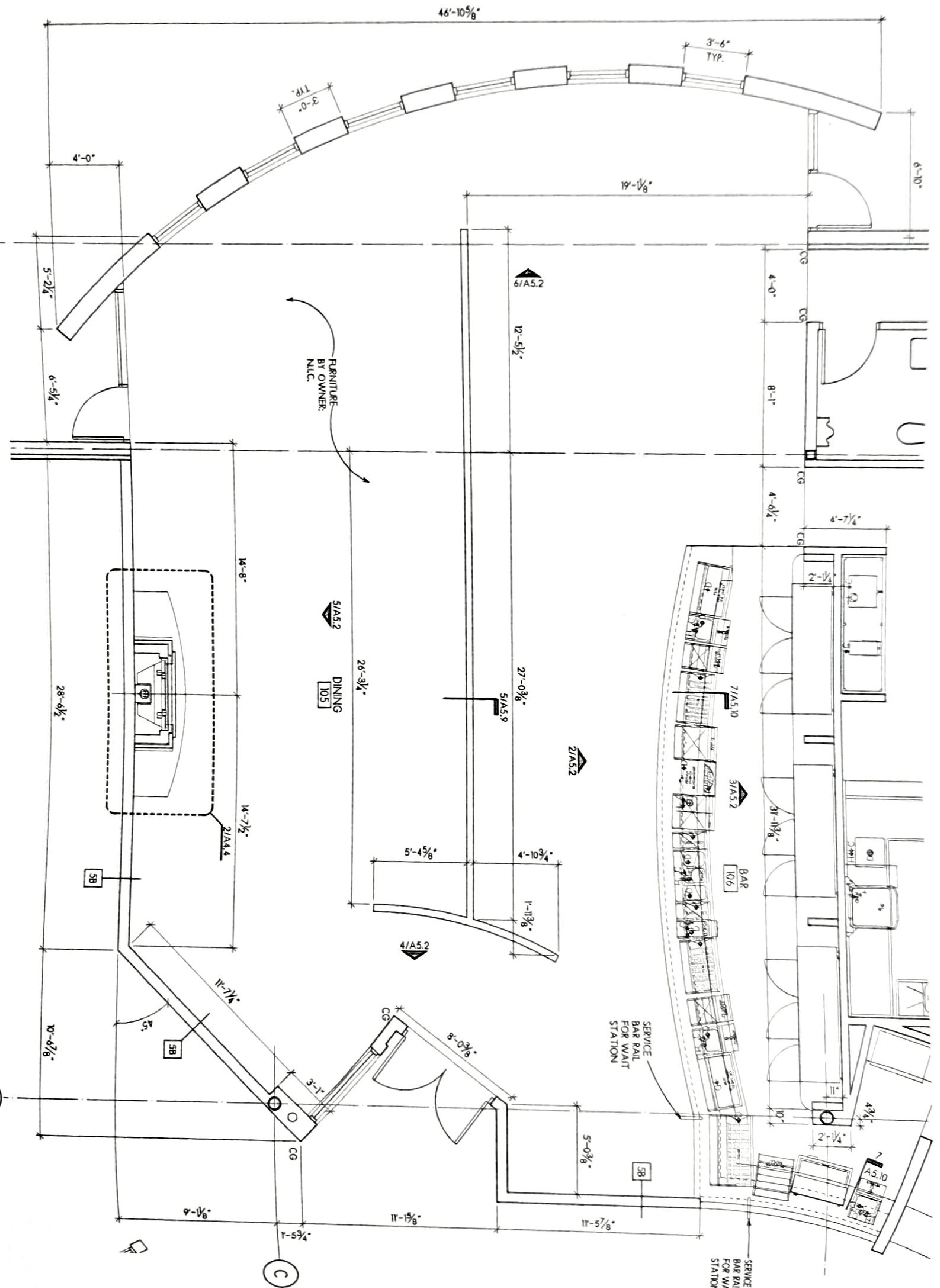

1 ENLARGED DINING AREA - 105
SCALE: 1/4" = 1'-0"

2

C

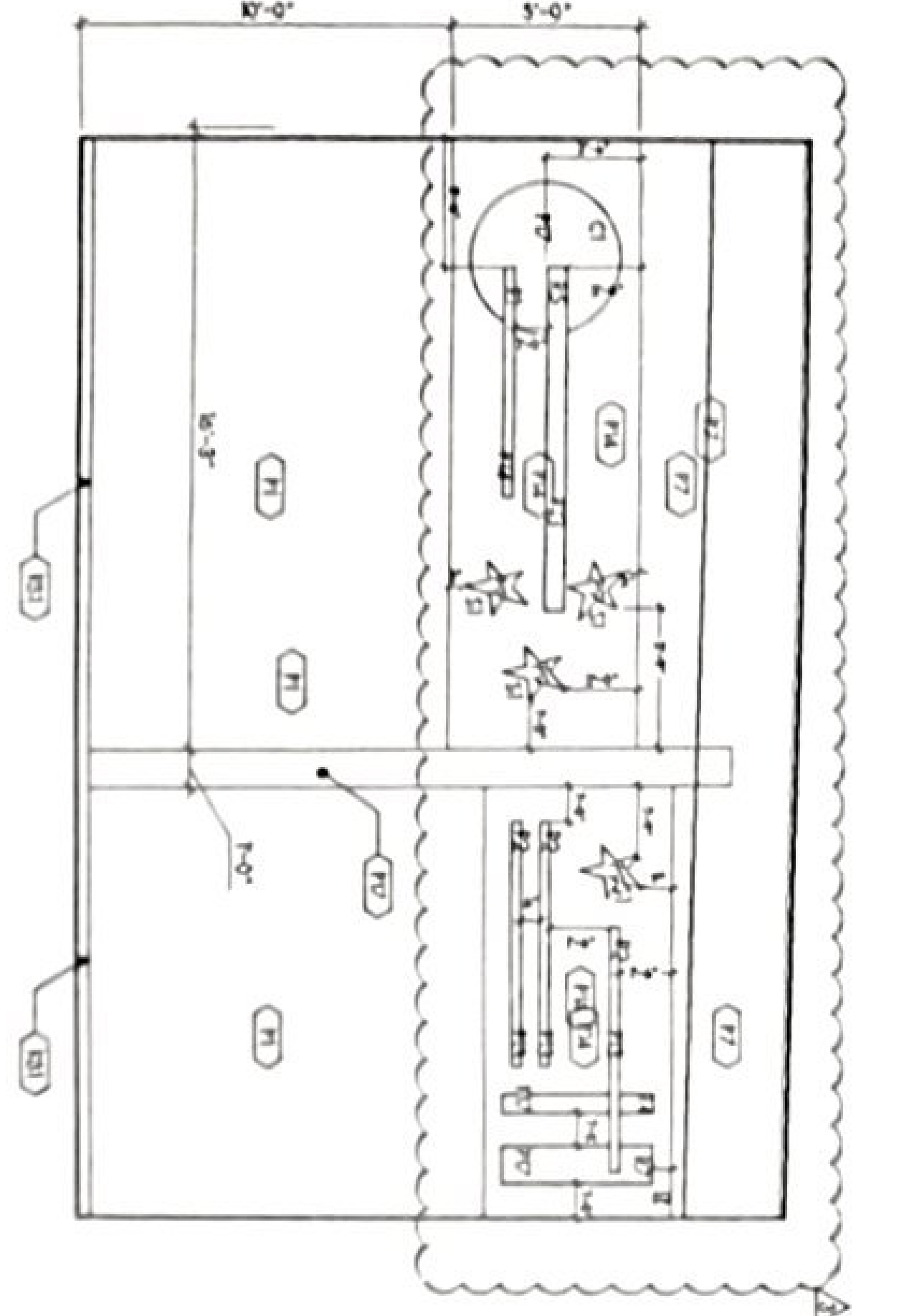

2 ARCADE - NORTH
SCALE: 1/4" = 1'-0"

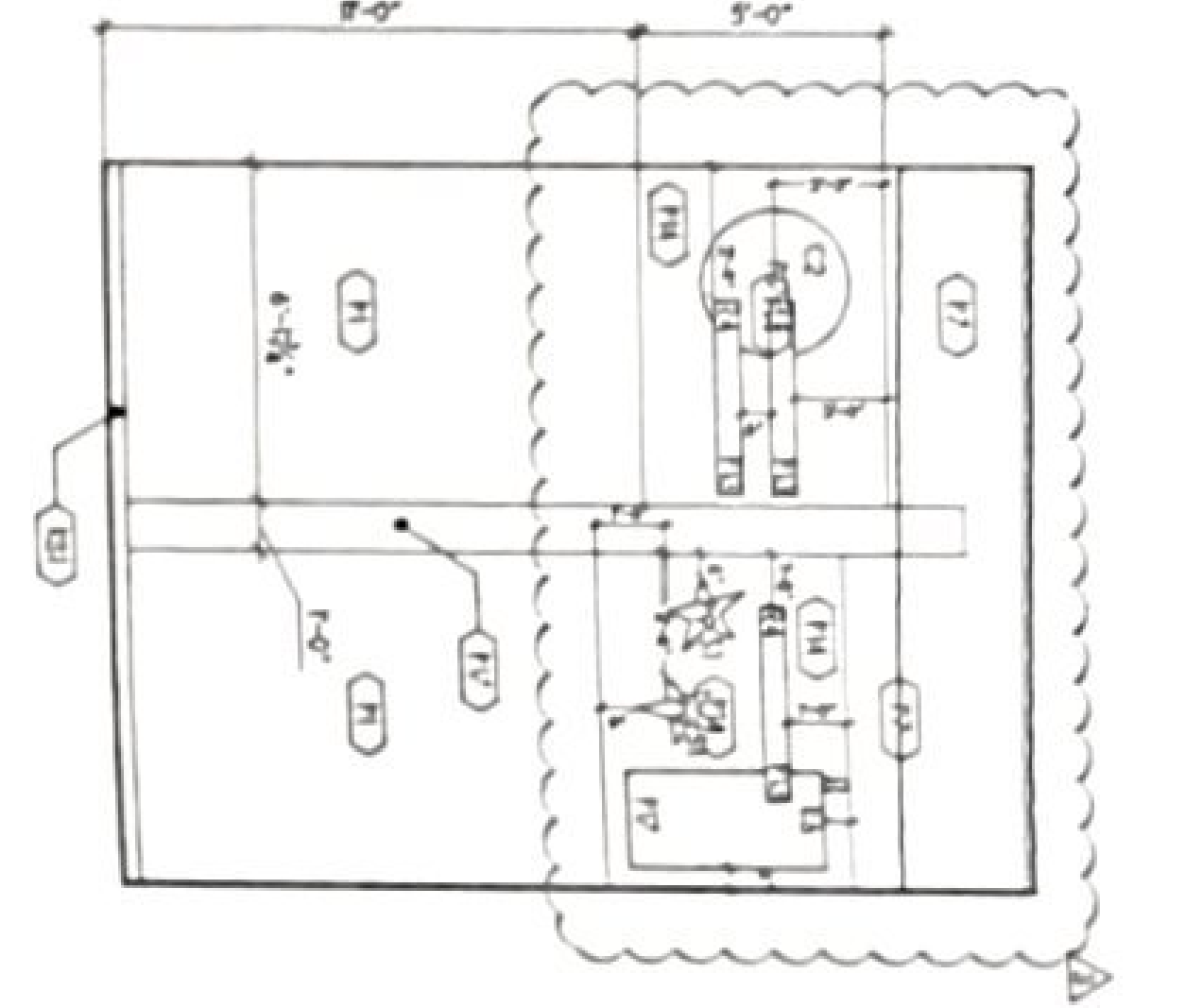

3 ARCADE - NORTH
SCALE: 1/4" = 1'-0"

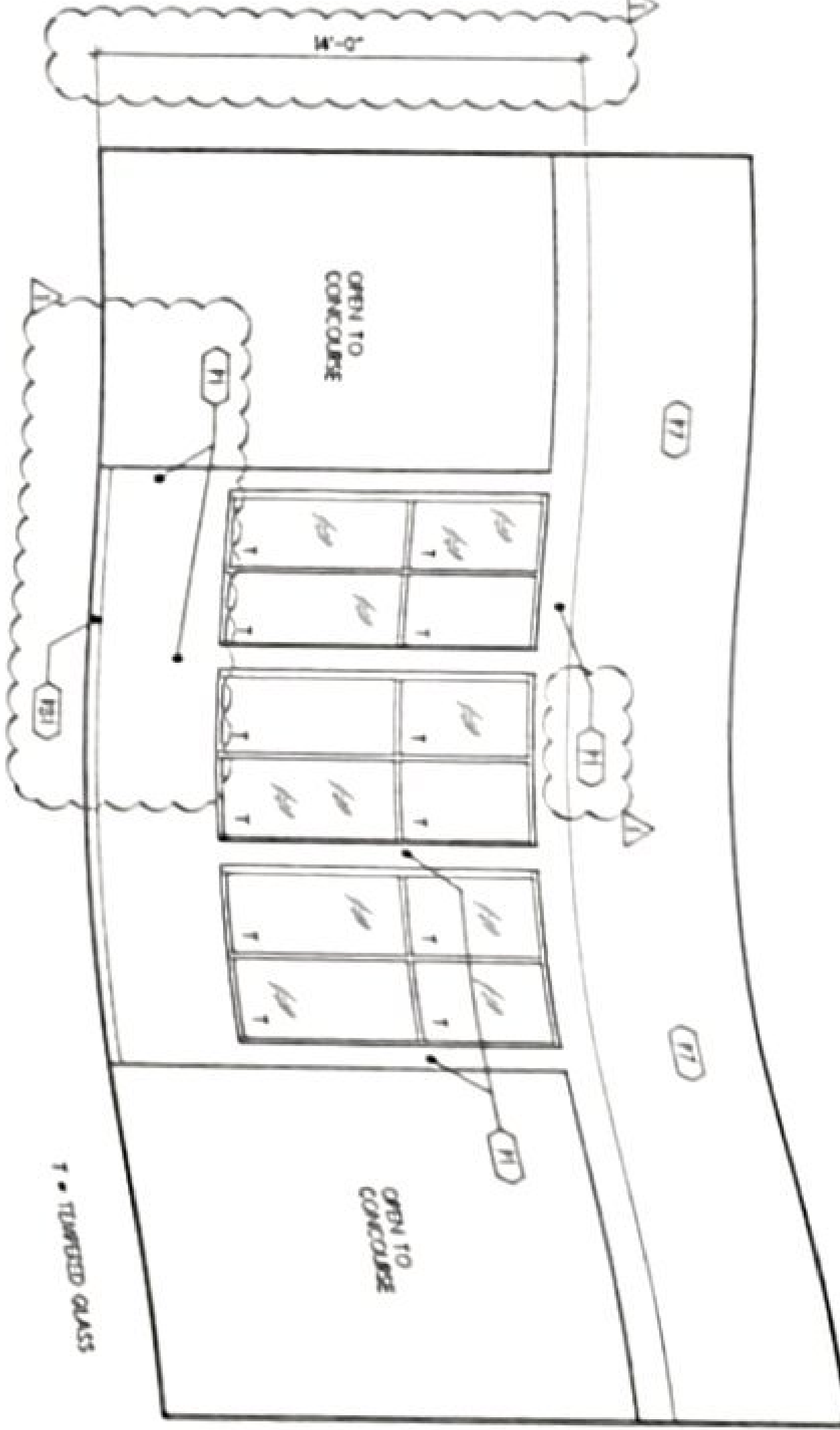

4 ARCADE - EAST
SCALE: 1/4" = 1'-0"

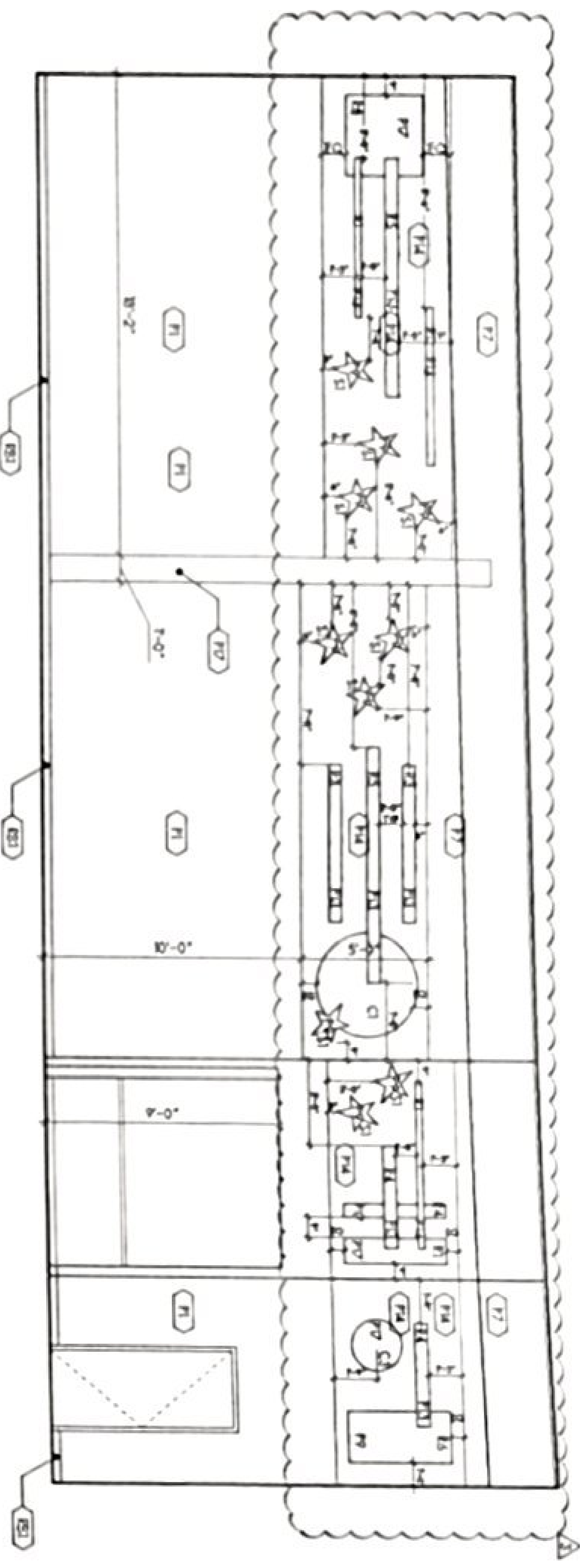

5 ARCADE - SOUTH
SCALE: 1/4" = 1'-0"

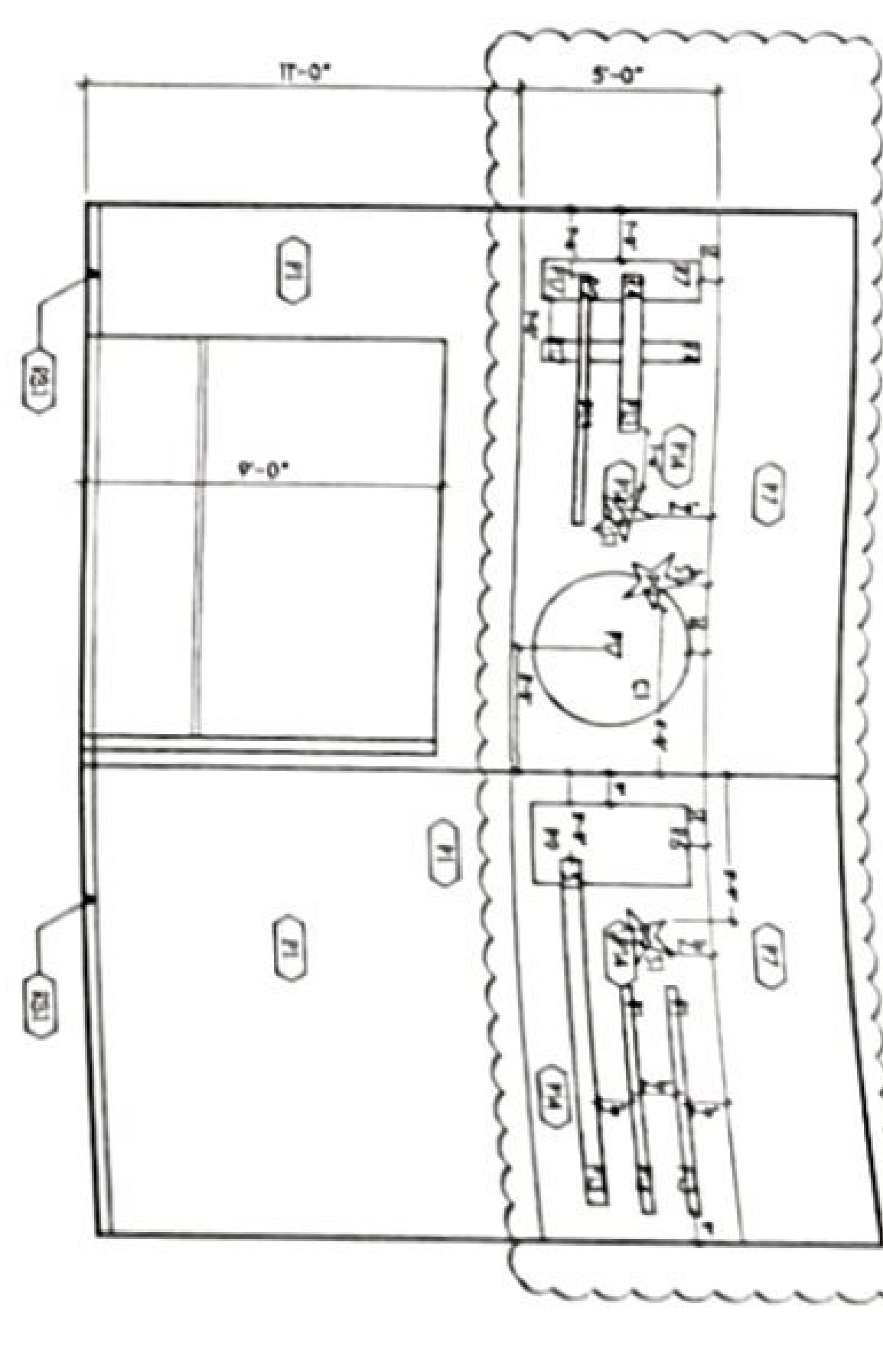

6 ARCADE - WEST
SCALE: 1/4" = 1'-0"

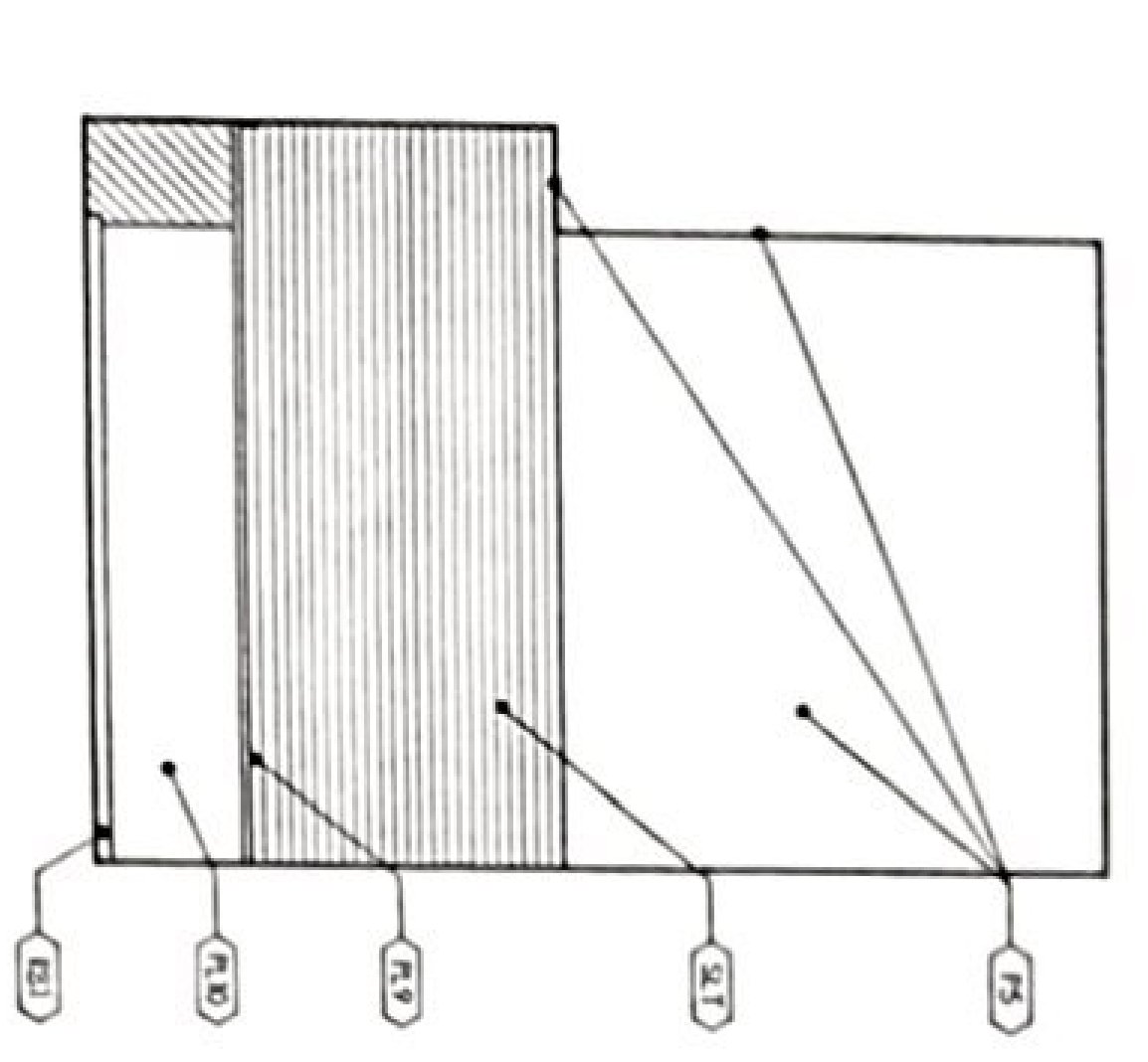

7 REDEMP.T. CENTER - WEST
SCALE: 1/4" = 1'-0"

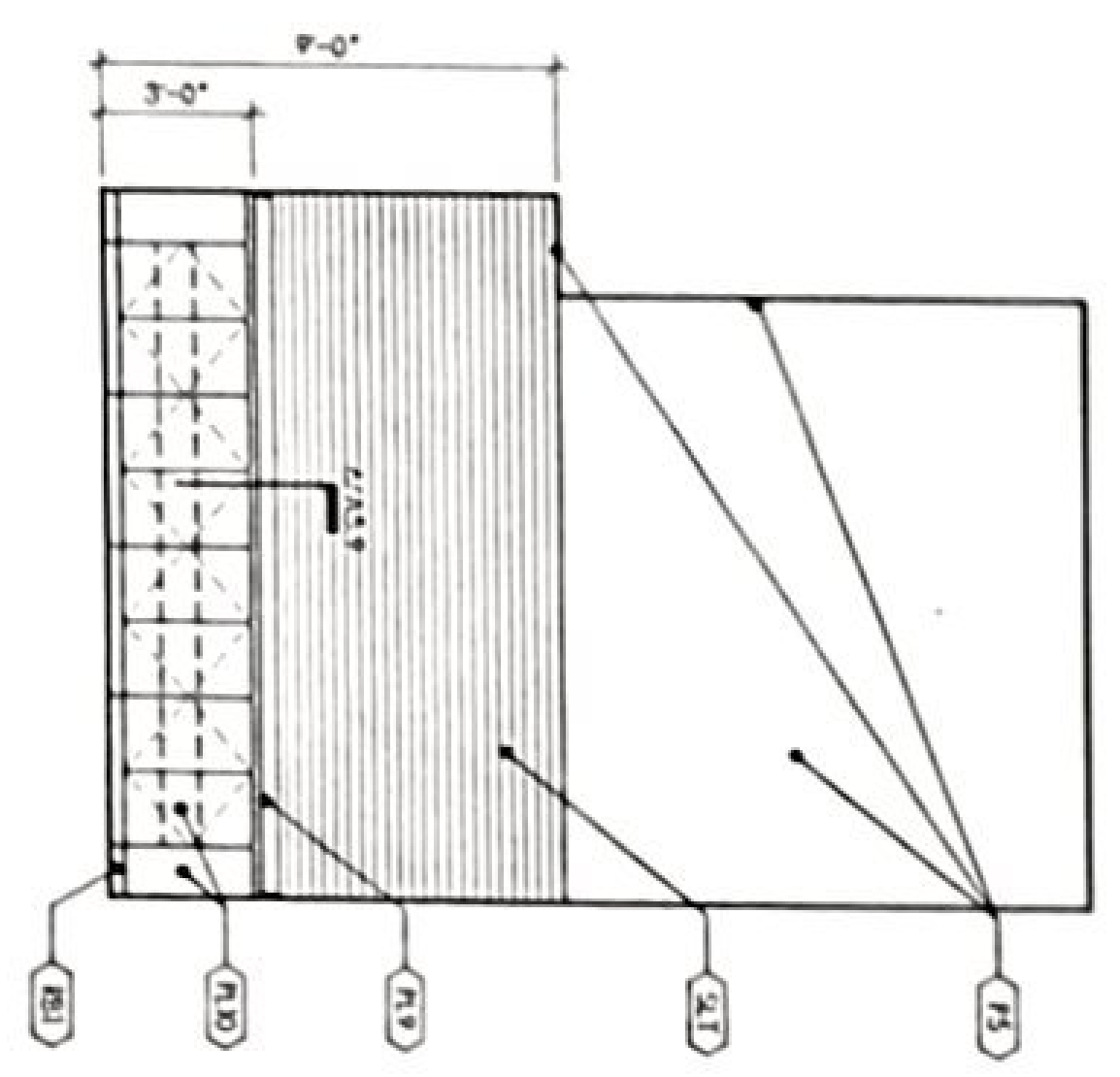

8 REDEMP.T. CENTER - WEST
SCALE: 1/4" = 1'-0"

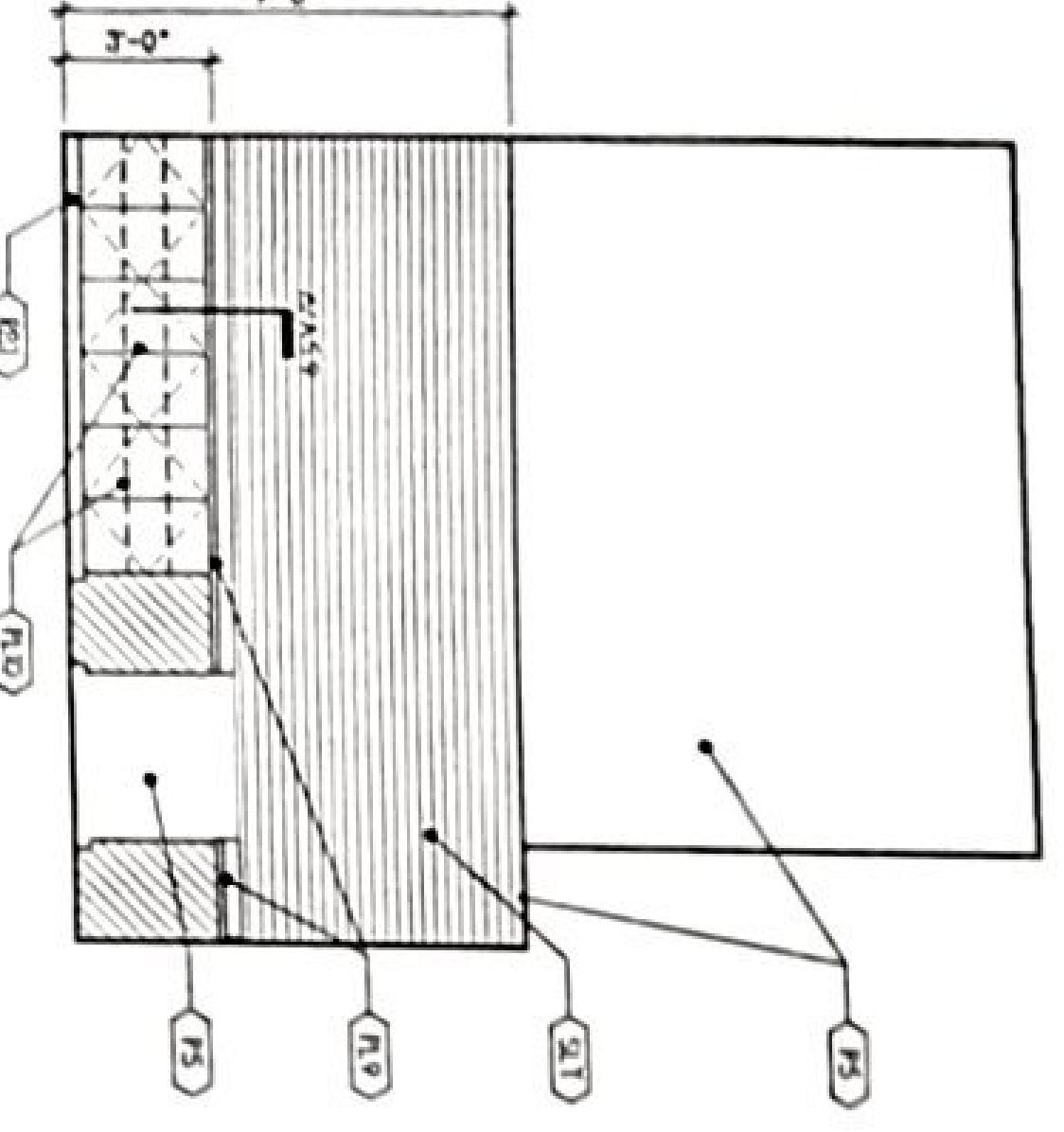

9 REDEMP.T. CENTER - SOUTH
SCALE: 1/4" = 1'-0"

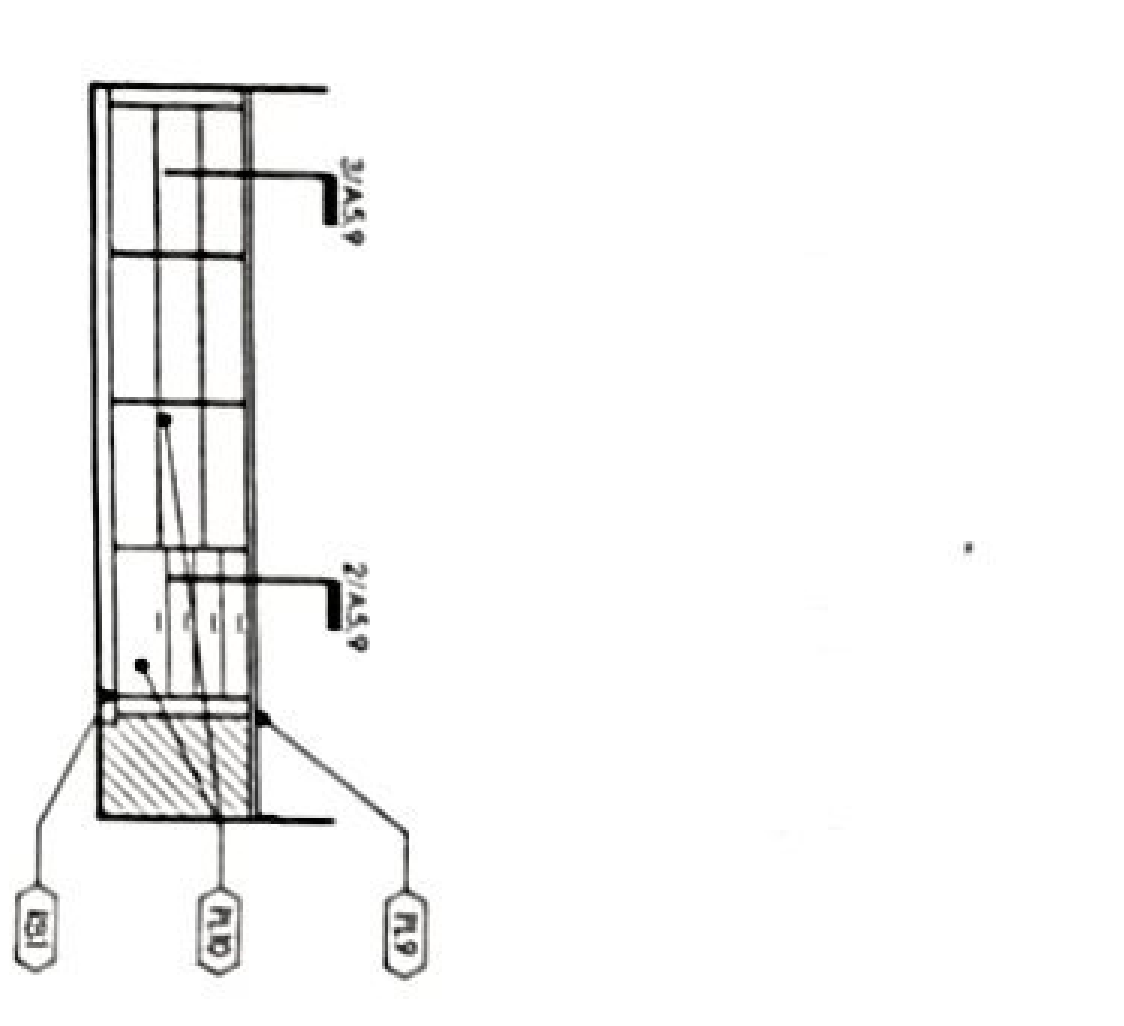

10 REDEMP.T. CENTER - EAST
SCALE: 1/4" = 1'-0"

GLAZING SET:

| | |
|-----------|-------------|
| R1 6x8 FT | C1 4 Double |
| R2 6x8 FT | C2 2 Double |
| R3 6x8 FT | C3 2 Double |
| R4 6x8 FT | C4 2 Double |
| R5 6x8 FT | C5 2 Double |
| R6 6x8 FT | C6 2 Double |
| R7 6x8 FT | C7 2 Double |
| R8 6x8 FT | C8 2 Double |

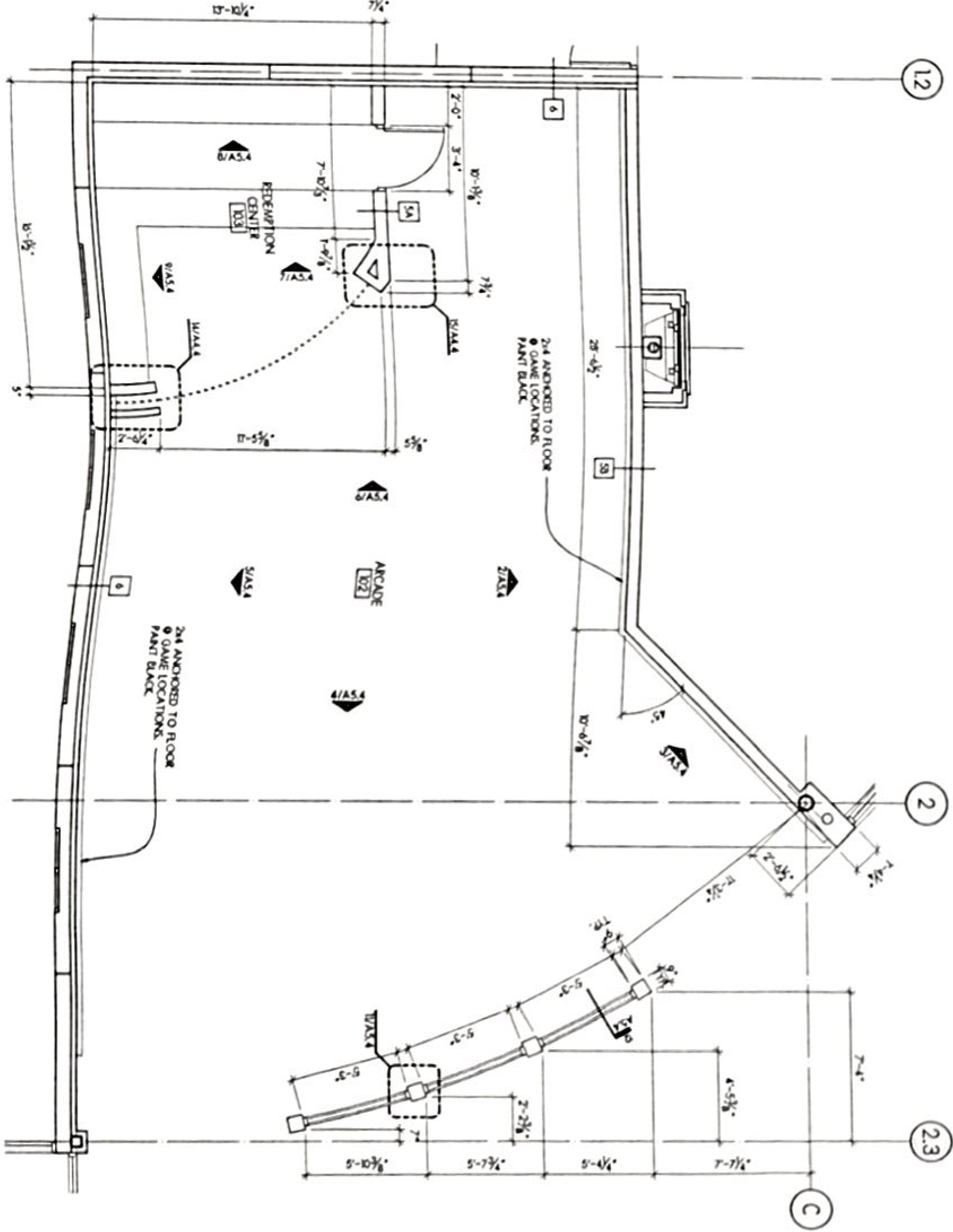

1 ARCADE - 102
SCALE: 1/4" = 1'-0"

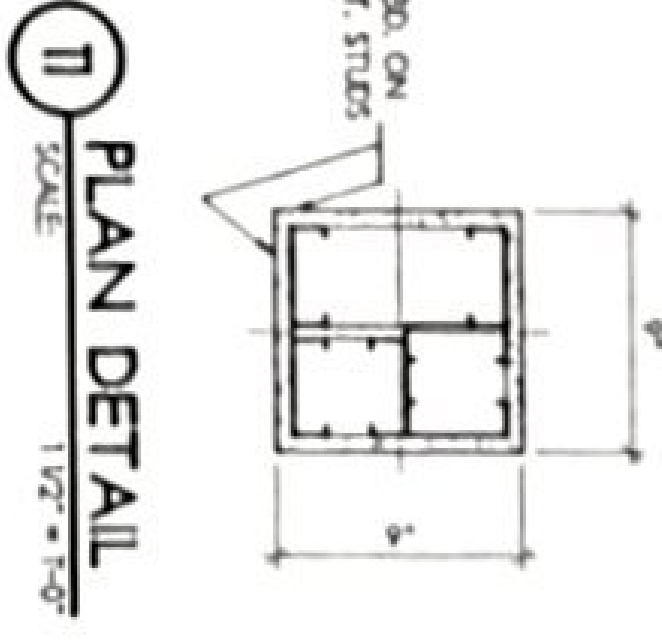

11 PLAN DETAIL
SCALE: 1/2" = 1'-0"

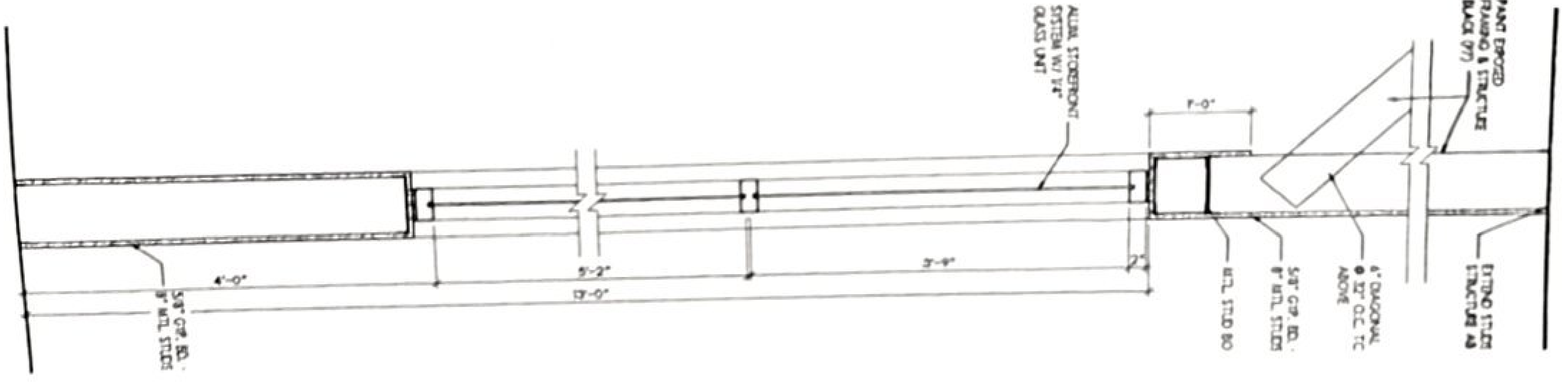

2 SECTION
SCALE: 1/4" = 1'-0"

- GENERAL NOTES:
1. PROVIDE EIGHT (8) INCHES (8") MINIMUM CLEARANCE BETWEEN WINDOW FRAME AND WALL.
 2. REMOVE FINISH AND OTHER MATERIALS (SIC) AS SHOWN.

ENLARGED PLANS AND INTERIOR ELEVATIONS
SCALE: 1/4" = 1'-0"

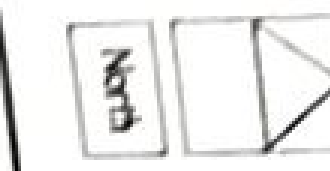

| | |
|-----------------------|-------------------------|
| DATE: 07/20/09 | ISSUED FOR: |
| PROJECT NUMBER: 18145 | BY: [Signature] |
| SHEET NUMBER: A5.4 | CHECKED BY: [Signature] |
| | DRAWN BY: JSW |
| | APPROVED BY: DJR |

A DESIGN FOR:
FAMILY ENTERTAINMENT CENTER
MARENGO, ILLINOIS

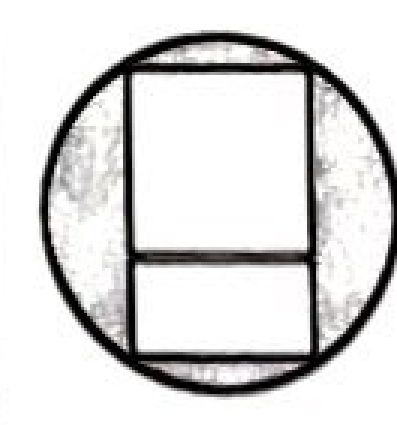

Larson & Darby Group
Architects Engineers Planners
Buffalo Office: 4817 Horton Ave., Suite 100, Buffalo, NY 14211, Tel: (716) 434-6221, Fax: (716) 434-6842
St. Charles Office: 2509 South St., St. Charles, IL 60154, Tel: (630) 444-3322, Fax: (630) 444-3343
Peoria Office: 214 SW Adams St., Suite 400, Peoria, IL 61602, Tel: (309) 673-3800, Fax: (309) 673-3420

