



AVION PLACE OFFICES FOR SALE

3775 BRICKWAY BLVD., SUITES 100 & 120, SANTA ROSA, CA 95403

500 BICENTENNIAL WAY, SUITE 310 | SANTA ROSA, CA 95403 | WCOMMERCIALRE.COM

OFFICE BUILDING FOR SALE



FOR MORE INFORMATION:

TODD SCHAPMIRE

707.570.9855

TODD@WREALESTATE.NET

CALDRE #01414195

AVION PLACE OFFICES FOR SALE

3775 BRICKWAY BLVD., SUITES 100 & 120, SANTA ROSA, CA 95403

EXECUTIVE SUMMARY



OFFERING SUMMARY

Sale Price:	\$899,000
Available SF:	2,942 SF
Building Size:	15,574 SF
Year Built:	2006
Zoning:	MP Industrial Park
APN:	059-380-011 & 059-380-012

PROPERTY OVERVIEW

Fantastic office spaces available in the Airport Business Park! Two ground floor suites are currently available totaling approximately 2,942 square feet. Suite 100 is about 1,726 square feet offering multiple executive offices with windows, a conference room, bullpen area, and kitchenette. Suite 120 is approximately 1,216 square feet including three executive offices with windows, a bullpen, and kitchenette. Avion Place is a four building, two-story, office complex offering a professional setting with modern finishes, glass-lined buildings, onsite parking, elevator access, and great signage on Airport Park Boulevard. Conveniently located near the SMART train station, just a couple blocks from Highway 101, and only half a mile to the Sonoma County Airport. Don't miss this opportunity to secure your ideal office space at this sought-after location.



TODD SCHAPMIRE
707.570.9855
TODD@WREALESTATE.NET
CALDRE #01414195

The above information, while not guaranteed, has been secured from sources we believe to be reliable. Submitted subject to error, change or withdrawal. An interested party should verify the status of the property and the information herein.

AVION PLACE OFFICES FOR SALE

3775 BRICKWAY BLVD., SUITES 100 & 120, SANTA ROSA, CA 95403

FLOOR PLAN

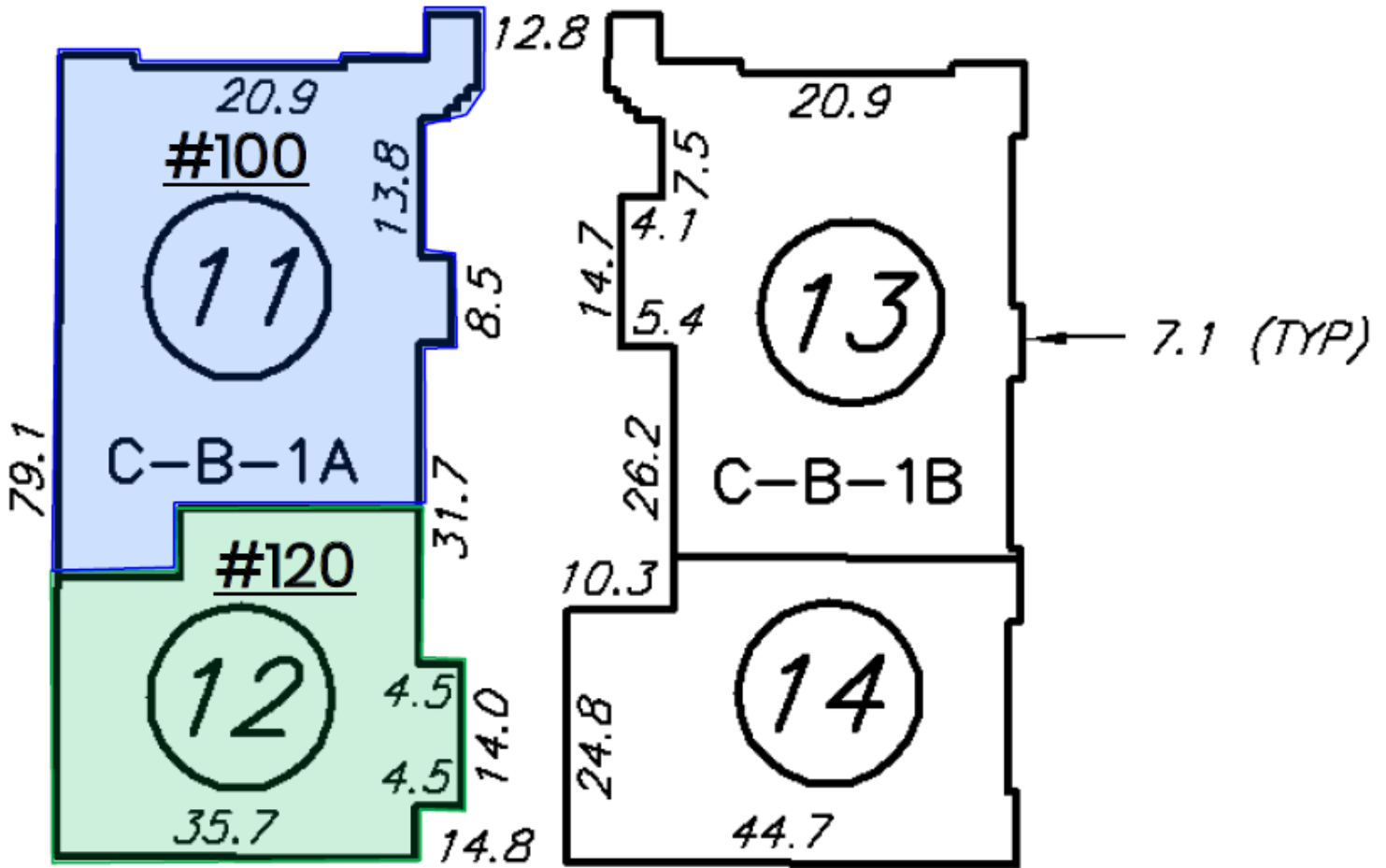

FIRST FLOOR BUILDING B

* Floor Plan is not exact. Any modifications above are an estimate. Tenant is advised to investigate and obtain professional inspections to provide exact measurements.



TODD SCHAPMIRE
707.570.9855
TODD@WREALESTATE.NET
CALDRE #01414195

The above information, while not guaranteed, has been secured from sources we believe to be reliable. Submitted subject to error, change or withdrawal. An interested party should verify the status of the property and the information herein.

AVION PLACE OFFICES FOR SALE

3775 BRICKWAY BLVD., SUITES 100 & 120, SANTA ROSA, CA 95403

AERIAL MAP

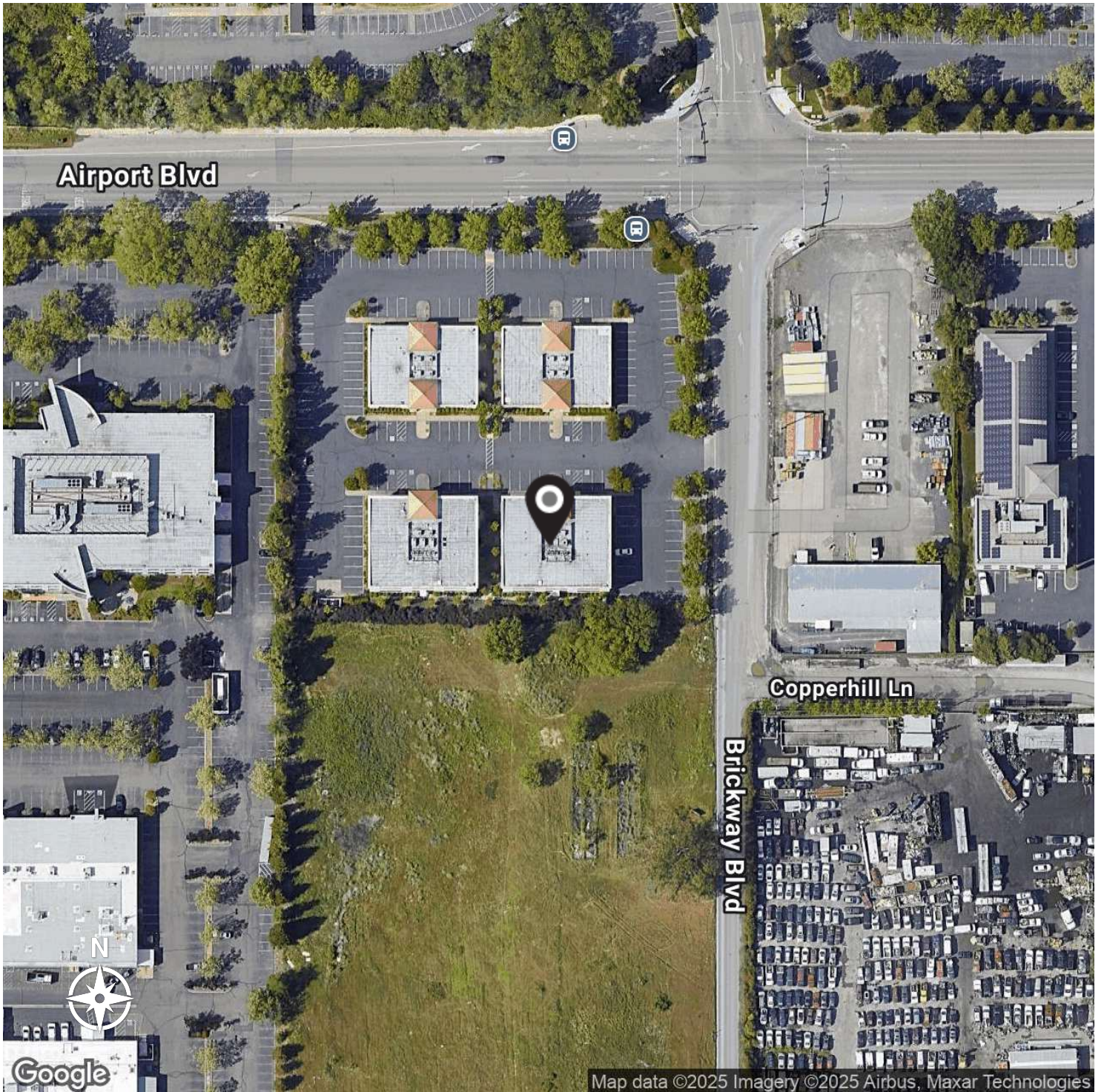

TODD SCHAPMIRE
707.570.9855
TODD@WREALESTATE.NET
CALDRE #01414195

The above information, while not guaranteed, has been secured from sources we believe to be reliable. Submitted subject to error, change or withdrawal. An interested party should verify the status of the property and the information herein.

AVION PLACE OFFICES FOR SALE

3775 BRICKWAY BLVD., SUITES 100 & 120, SANTA ROSA, CA 95403

LOCATION MAP

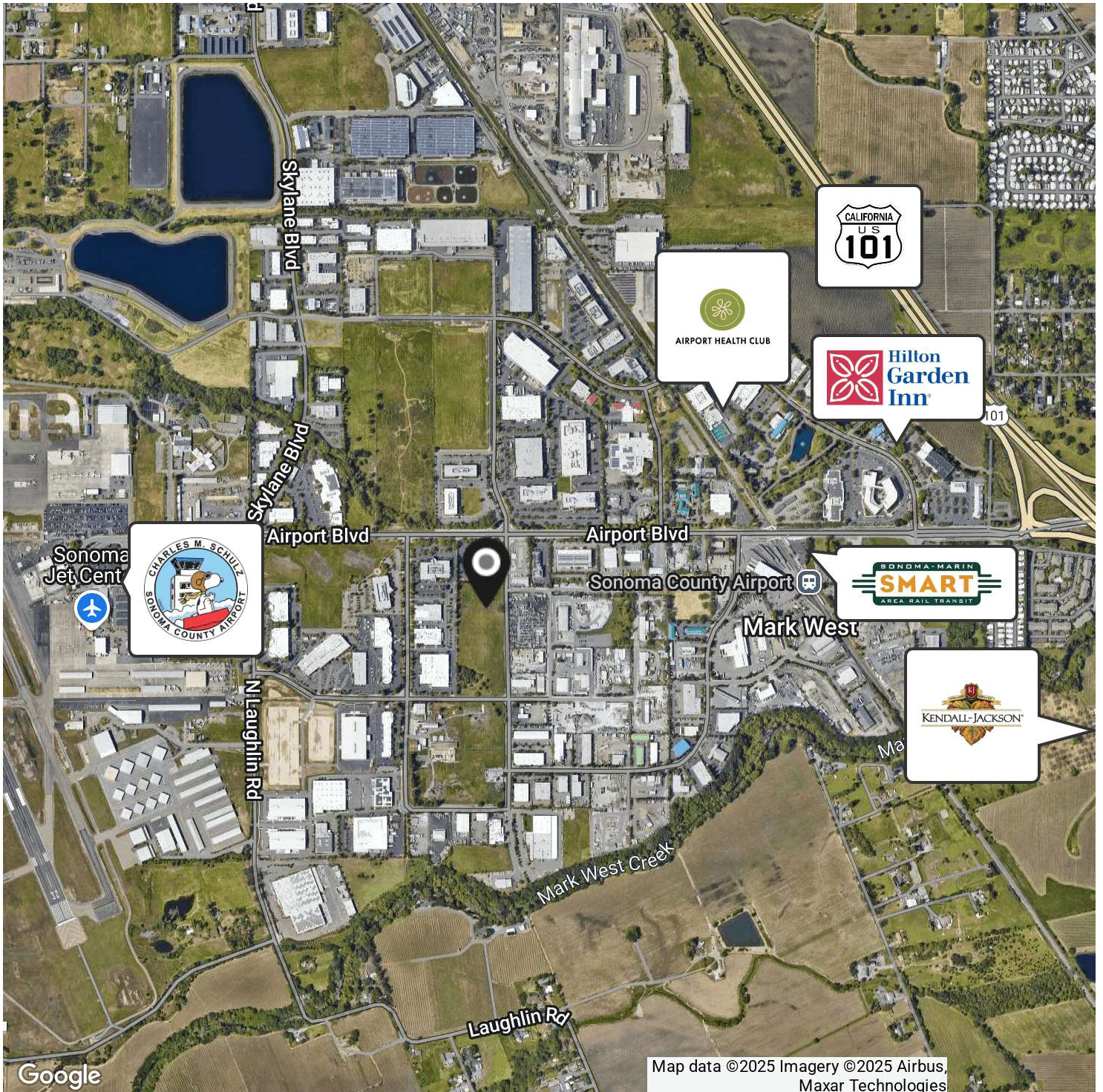

TODD SCHAPMIRE
707.570.9855
TODD@WREALESTATE.NET
CALDRE #01414195

The above information, while not guaranteed, has been secured from sources we believe to be reliable. Submitted subject to error, change or withdrawal. An interested party should verify the status of the property and the information herein.

AVION PLACE OFFICES FOR SALE

3775 BRICKWAY BLVD., SUITES 100 & 120, SANTA ROSA, CA 95403

AREA MAP

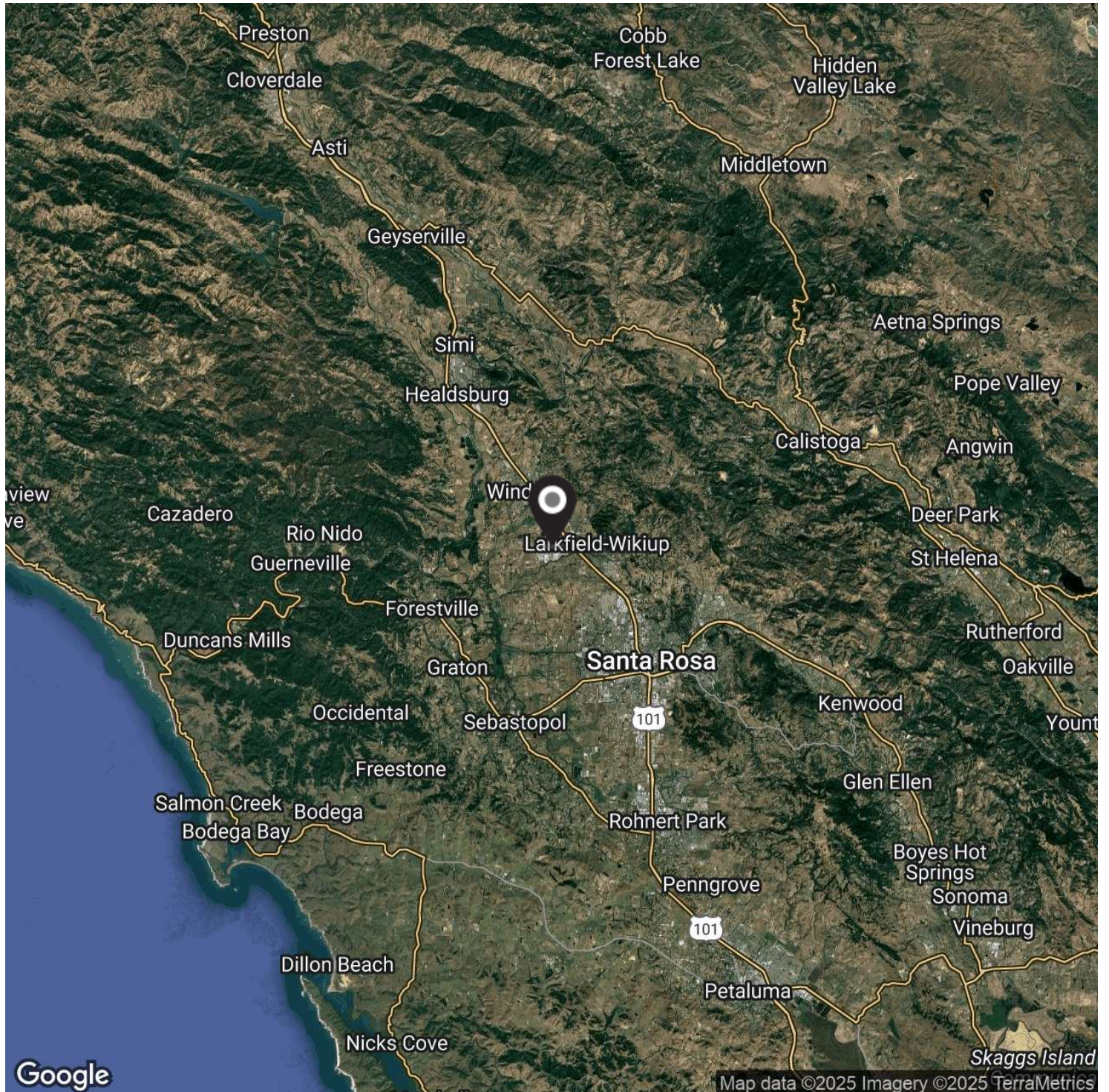

TODD SCHAPMIRE
707.570.9855
TODD@WREALESTATE.NET
CALDRE #01414195

The above information, while not guaranteed, has been secured from sources we believe to be reliable. Submitted subject to error, change or withdrawal. An interested party should verify the status of the property and the information herein.

AVION PLACE OFFICES FOR SALE

3775 BRICKWAY BLVD., SUITES 100 & 120, SANTA ROSA, CA 95403

PHOTOS



TODD SCHAPMIRE
707.570.9855
TODD@WREALESTATE.NET
CALDRE #01414195

The above information, while not guaranteed, has been secured from sources we believe to be reliable. Submitted subject to error, change or withdrawal. An interested party should verify the status of the property and the information herein.

AVION PLACE OFFICES FOR SALE

3775 BRICKWAY BLVD., SUITES 100 & 120, SANTA ROSA, CA 95403

DEMOGRAPHICS MAP & REPORT

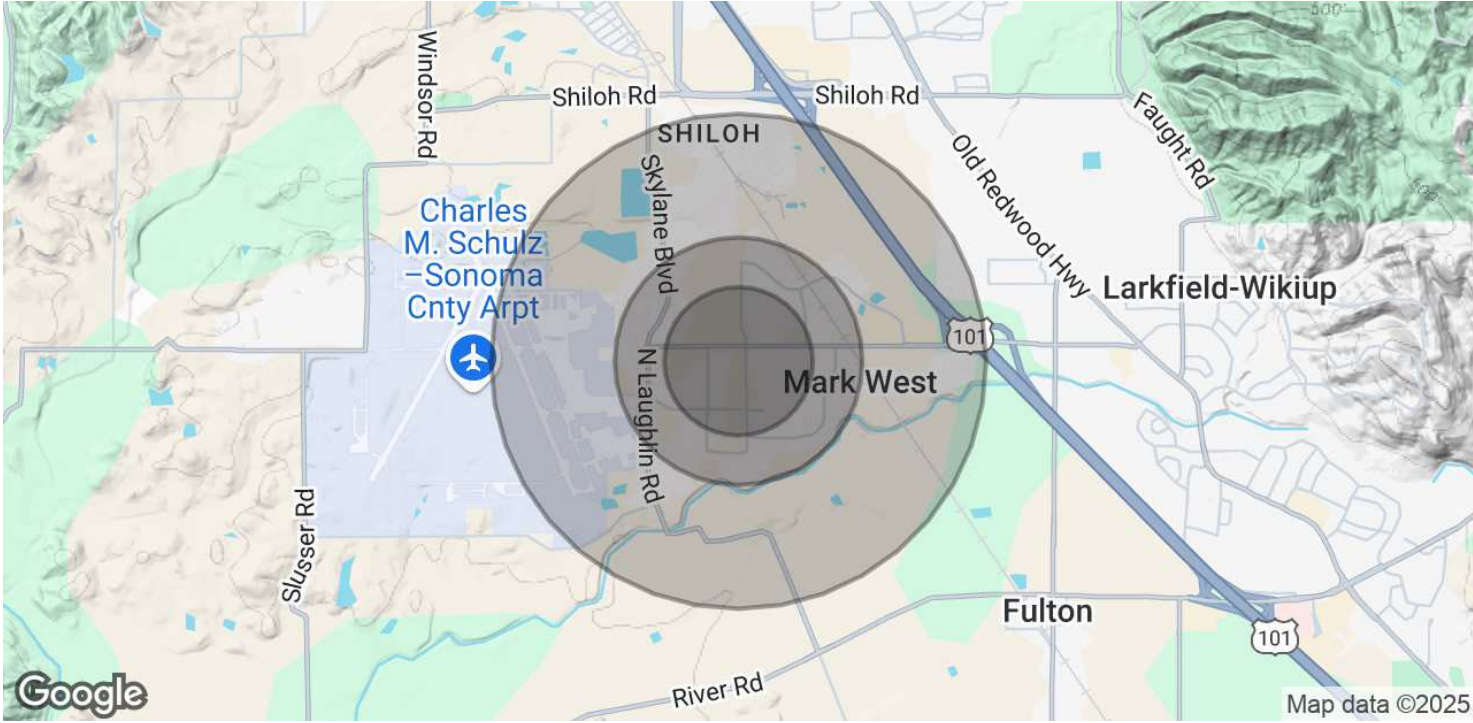

POPULATION	0.3 MILES	0.5 MILES	1 MILE
Total Population	41	223	1,365
Average Age	45	45	44
Average Age (Male)	45	45	43
Average Age (Female)	45	45	44

HOUSEHOLDS & INCOME	0.3 MILES	0.5 MILES	1 MILE
Total Households	13	69	555
# of Persons per HH	3.2	3.2	2.5
Average HH Income	\$137,601	\$137,596	\$115,537
Average House Value	\$1,031,546	\$1,031,509	\$783,941

* Demographic data derived from 2020 ACS - US Census



TODD SCHAPMIRE
 707.570.9855
 TODD@WREALESTATE.NET
 CALDRE #01414195

The above information, while not guaranteed, has been secured from sources we believe to be reliable. Submitted subject to error, change or withdrawal. An interested party should verify the status of the property and the information herein.