

# 1712 - 1714 North Wells

2 X 1,440 SF RETAIL OPPORTUNITIES  
IN OLD TOWN, CHICAGO



[savills.us](https://www.savills.us)

## THE NEIGHBORHOOD ▶

## THE LOCATION

The sites are conveniently located several blocks from the CTA Sedgwick “L” stop and steps away from North Avenue and Lake Shore Drive (over 150,000 VPD). Nearby attractions include Lincoln Park Zoo, Second City and the Chicago History Museum as well as neighboring cotenants, Chase, Fleet Feet and Green. Lastly, the spaces conveniently offer a full basement and wide sidewalks allowing outdoor seating potential.



# SITE PLAN

**1700-02**  
N. WELLS ST.

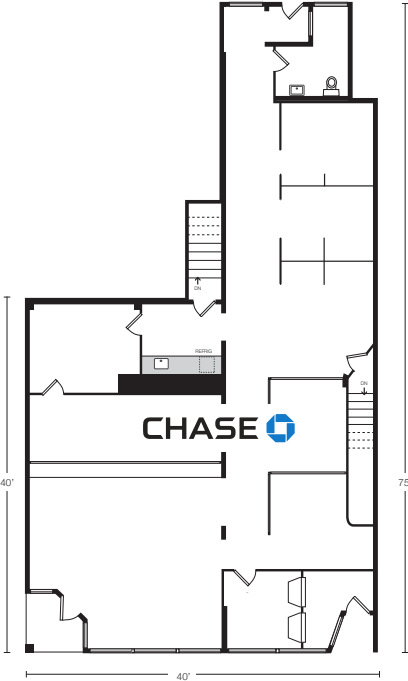

**1704**  
N. WELLS ST.

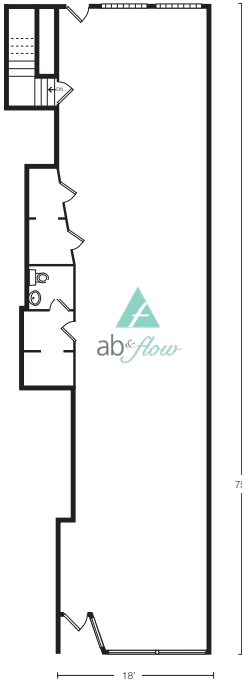

**1706-08**  
N. WELLS ST.

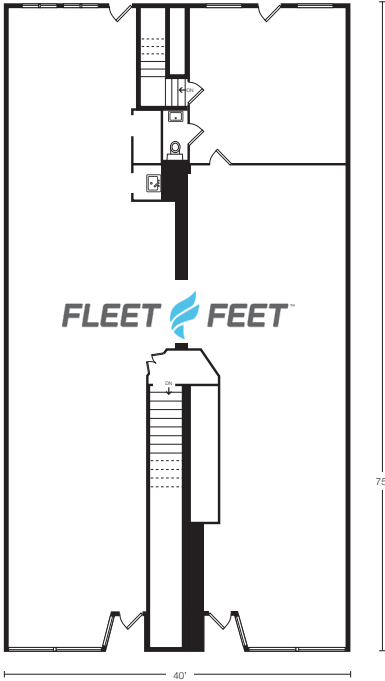

**1710**  
N. WELLS ST.



**1712**  
N. WELLS ST.

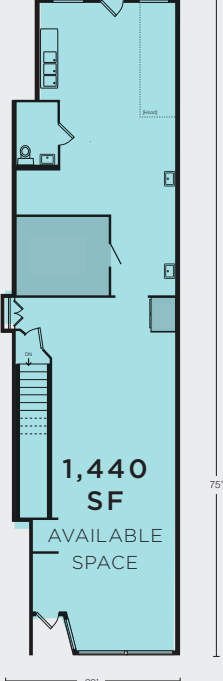

**1714**  
N. WELLS ST.

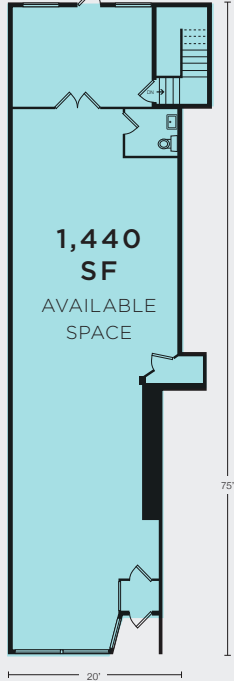

**1716-18**  
N. WELLS ST.

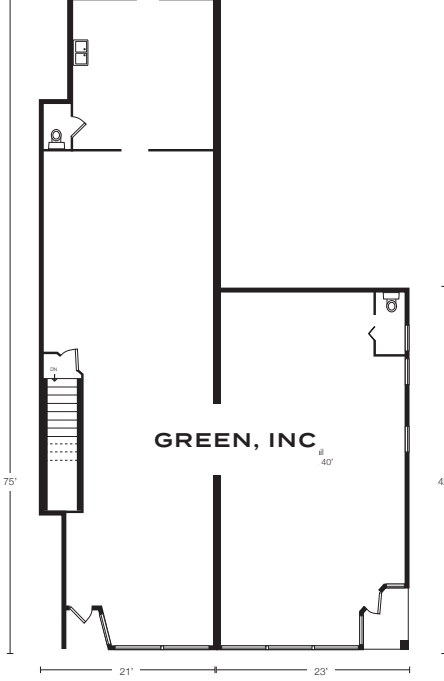

Can combine  
up to 2,880 SF

## THE OPPORTUNITY

1712 & 1714 N. Wells offer rarely available small shop spaces located in the heart of Old Town. Old Town benefits from the dense, affluent residential population and vibrant nightlife, which produces some of Chicago's strongest retail and restaurant sales.



**71,333**  
POPULATION



**\$2.4 B**  
ANNUAL RETAIL  
SALES



**6,800**  
WELLS ST.

**37,000**  
CLARK ST.

**37,000**  
NORTH AVE.

AVERAGE DAILY  
VEHICLES



**SEDGWICK**  
"L" STOP

PUBLIC  
TRANSPORTATION



**676,742**  
ANNUAL RIDERS



**65,265**  
DAYTIME  
POPULATION



**176,622**  
AVERAGE  
HH INCOME

**PHIL GOLDING**  
+1 312 404 6673  
pgolding@savills.us

**KIMBERLY WISKUP**  
+1 312 595 2917  
kwiskup@savills.us



[savills.us](https://www.savills.us)