

DeLand Industrial Center

Old Daytona Rd & Old Daytona Circle
DeLand, FL 32724

435 - 7,037 SF Industrial/Flex Spaces & Industrial Outside Storage Available



Contact Us

Alex Eastwood
Senior Associate
850 356 8231
alex.eastwood@cbre.com

Cameron Thomas
Senior Associate
407 404 5078
cameron.thomas@cbre.com

Jose Rivera
Associate
407 404 5067
jose.rivera1@cbre.com

Park Overview



SPACE	SUITE #	SQUARE FEET	RATE/MONTH
1601 Old Daytona Rd	1601	1,099	\$1,579.81
500 Old Daytona	1522	1,022	\$1,022.00
500 Old Daytona	1526	1,011	\$1,011.00
500 Old Daytona	1544-1548	2,069	\$2,069.00
502 Old Daytona	1541-1542	998	\$1,000.00
502 Old Daytona	1544-1550	2,083	\$2,083.00
504 Old Daytona	1531-1664	1,000	\$1,000.00
504 Old Daytona	1511	1,011	\$1,011.00
504 Old Daytona	1680	435	\$551.00
506 Old Daytona Cir	1556	1,025	\$1,110.42
506 Old Daytona Cir	1576	1,029	\$1,114.75
506 Old Daytona Cir	1580	1,000	\$1,208.33
506 Old Daytona Cir	1584	1,243	\$1,398.80
601 Old Daytona Rd	⊕	1,184	\$1,603.33
207 Old Daytona Rd	1	3,136	\$4,050.67
207 Old Daytona Rd	2	3,901	\$5,038.79
1629 Parade Cir D & E	D & E	2,105	\$2,280.42

Contact Us

Alex Eastwood
850 356 8231

Cameron Thomas
407 404 5078

Jose Rivera (Español)
407 404 5067



1601-1636 Old Daytona St

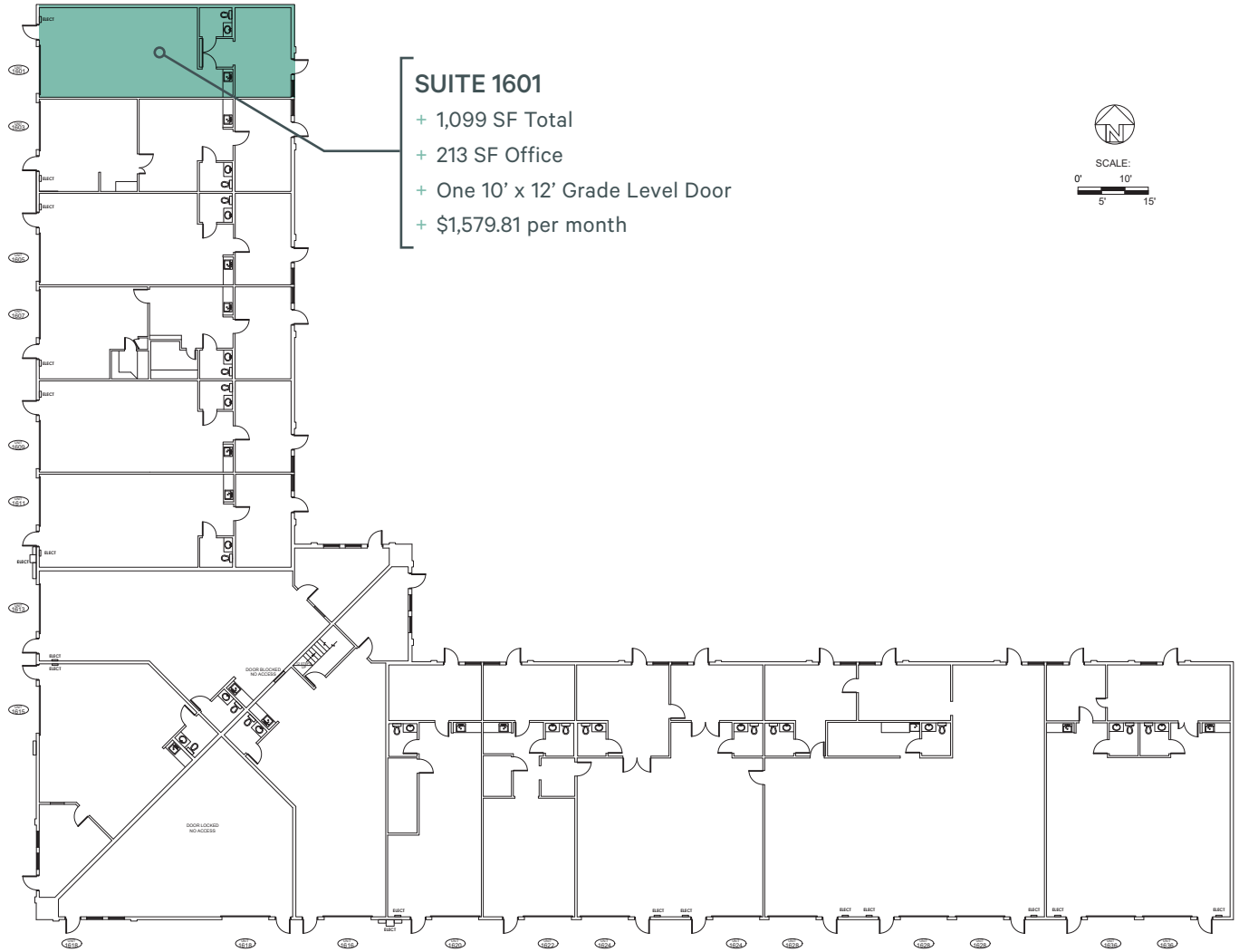

Contact Us

Alex Eastwood
850 356 8231

Cameron Thomas
407 404 5078

Jose Rivera (Español)
407 404 5067



Bldg 500

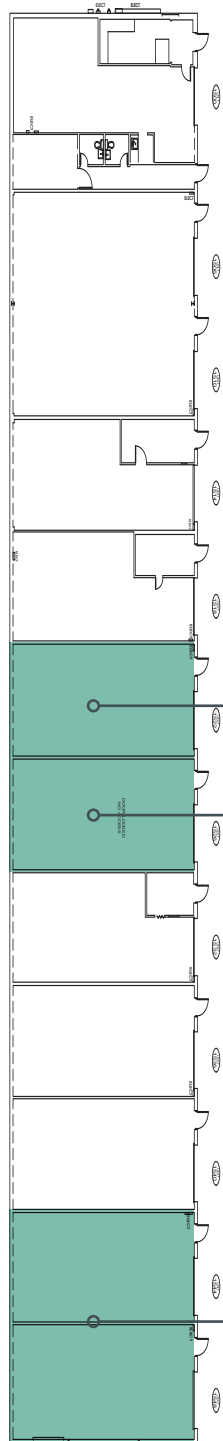

Suite 1522

- + 1,022 SF Total
- + 0 SF Office
- + One 10' x 10' Grade Level Door
- + \$1,022.00 per month

Suite 1526

- + 1,011 SF Total
- + 0 SF Office
- + One 10' x 10' Grade Level Door
- + \$1,011.00 per month

Suite 1544

- + 999 SF Total
- + 0 SF Office
- + One 10' x 10' Grade Level Door
- + \$999.00 per month

Suite 1544-1548 (combined)

- + 2,069 SF Total
- + 0 SF Office
- + Two 10' x 10' Grade Level Doors
- + \$2,069.00 per month

Suite 1548

- + 1,070 SF Total
- + 0 SF Office
- + One 10' x 10' Grade Level Door
- + \$1,070.00 per month

Contact Us

Alex Eastwood
850 356 8231

Cameron Thomas
407 404 5078

Jose Rivera (Español)
407 404 5067



Bldg 502

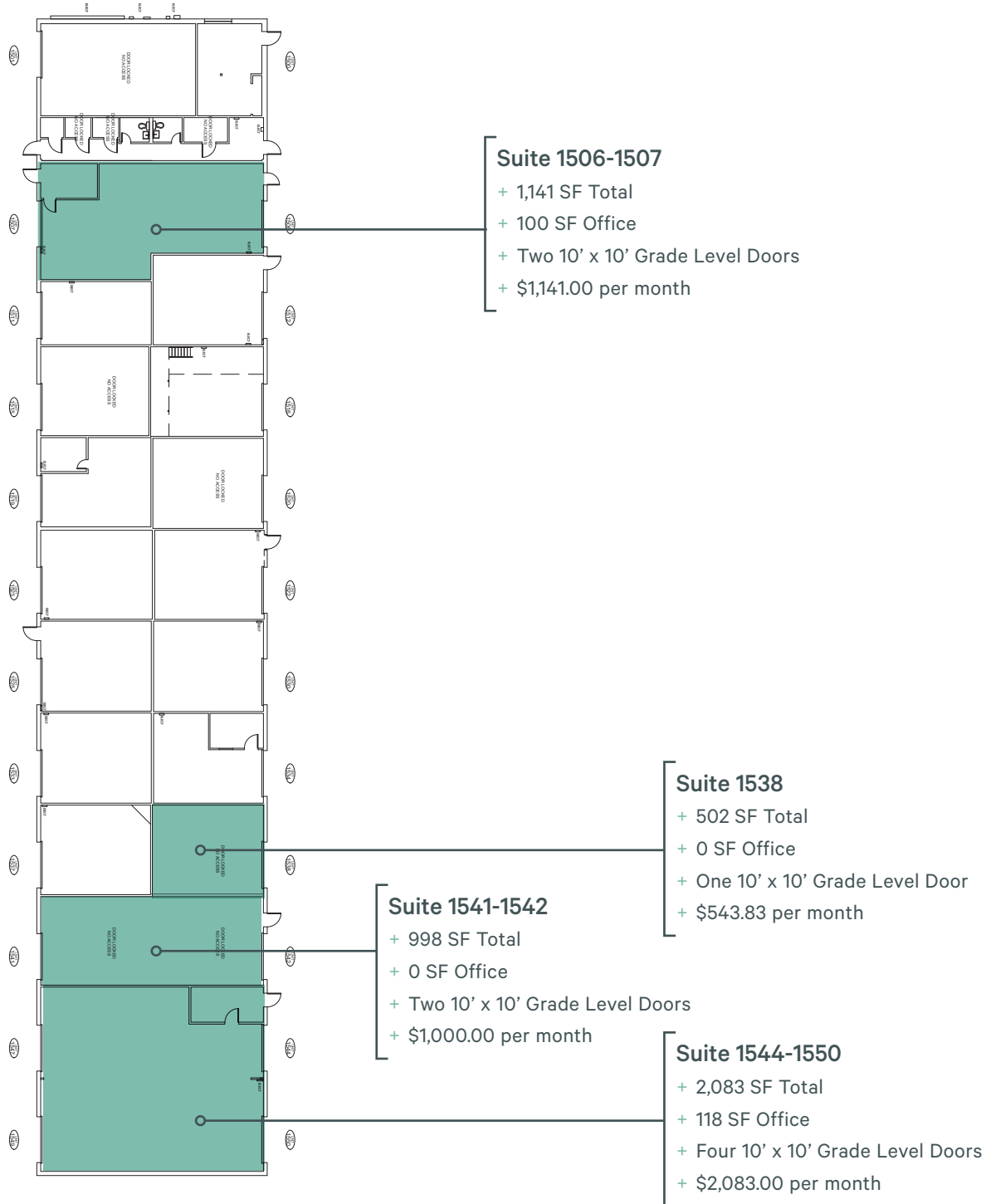

Contact Us

Alex Eastwood
850 356 8231

Cameron Thomas
407 404 5078

Jose Rivera (Español)
407 404 5067



Bldg 504

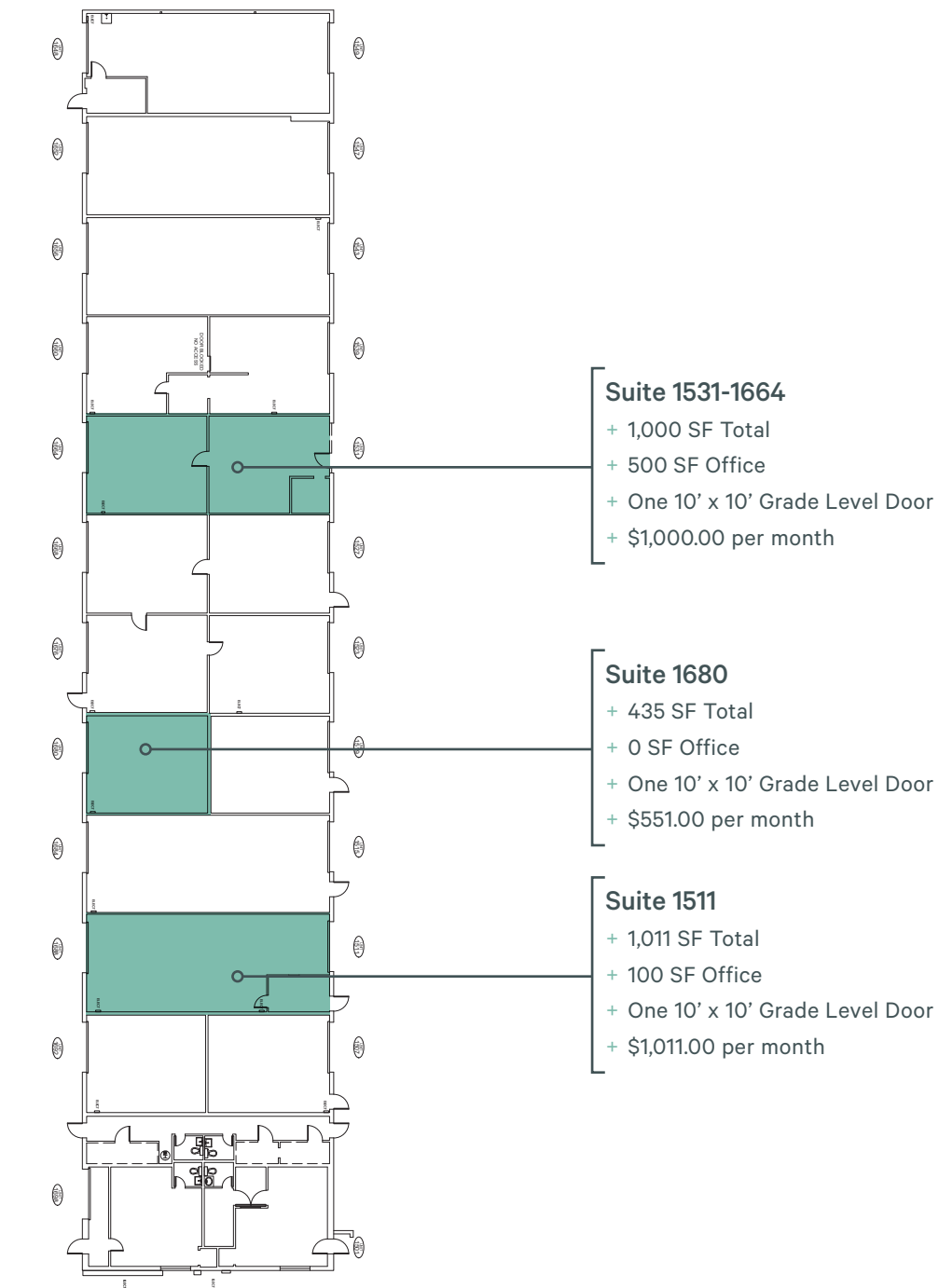

Contact Us

Alex Eastwood
850 356 8231

Cameron Thomas
407 404 5078

Jose Rivera (Español)
407 404 5067



Bldg 506

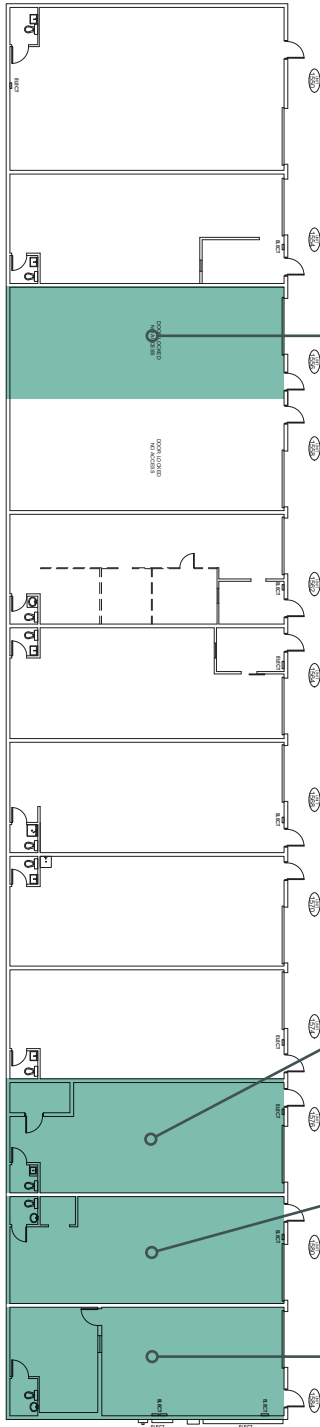

Suite 1556

- + 1,025 SF Total
- + TBD Office
- + One 10' x 10' Grade Level Door
- + \$1,110.42 per month

Suite 1576

- + 1,029 SF Total
- + 0 SF Office
- + One 10' x 10' Grade Level Door
- + \$1,114.75 per month

Suite 1580

- + 1,000 SF Total
- + 0 SF Office
- + One 10' x 10' Grade Level Door
- + \$1,208.33 per month

Suite 1584

- + 1,243 SF Total
- + 300 SF Office
- + One 10' x 10' Grade Level Door
- + \$1,398.80 per month

Contact Us

Alex Eastwood
850 356 8231

Cameron Thomas
407 404 5078

Jose Rivera (Español)
407 404 5067



601 Old Daytona Rd

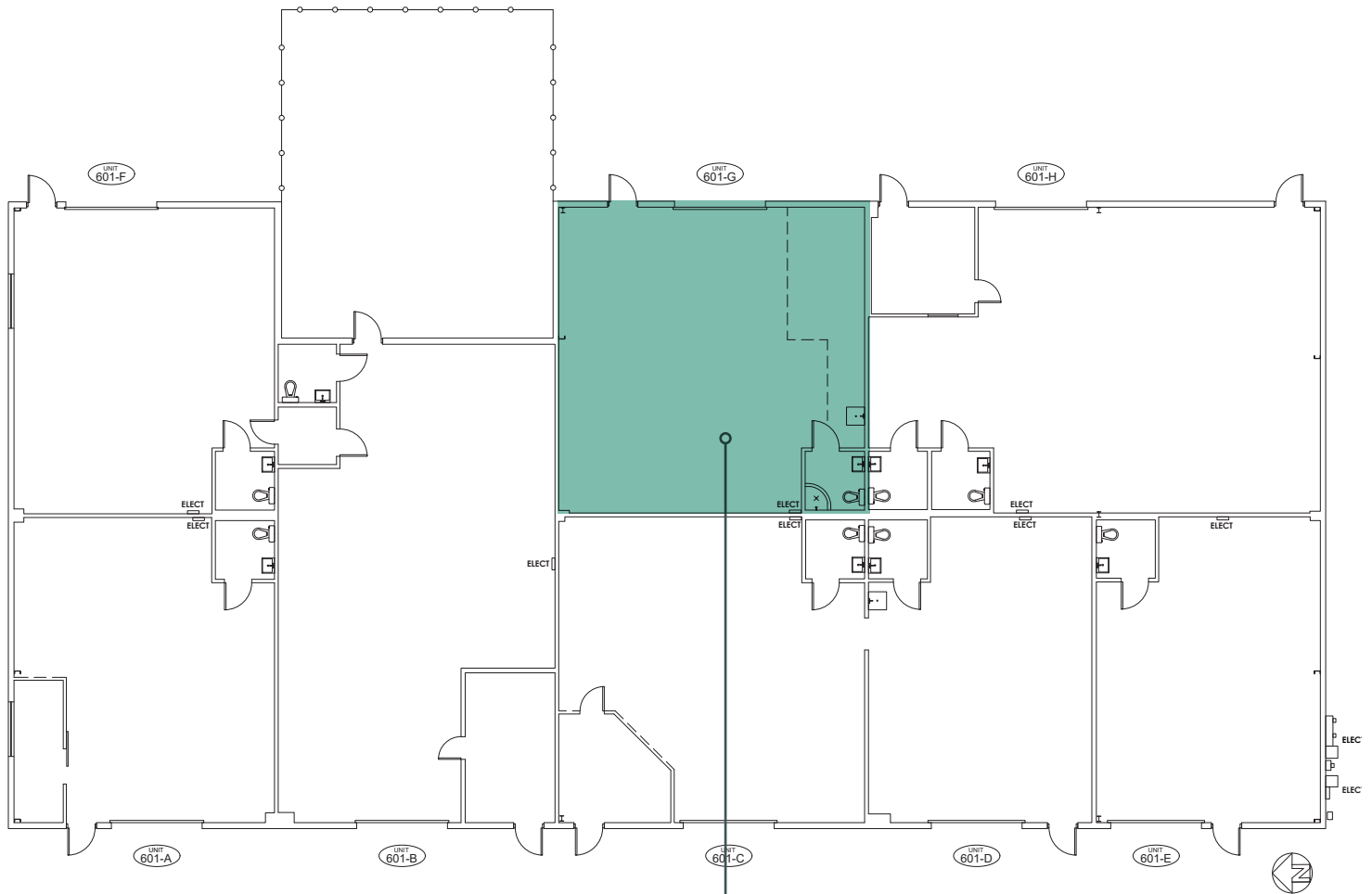

Suite G

- + 1,184 SF Total
- + 0 SF Office
- + One 10' x 10' Grade Level Door
- + \$1,603.33 NNN per month (All-in Cost)

Contact Us

Alex Eastwood
850 356 8231

Cameron Thomas
407 404 5078

Jose Rivera (Español)
407 404 5067

CBRE

207 Old Daytona Road

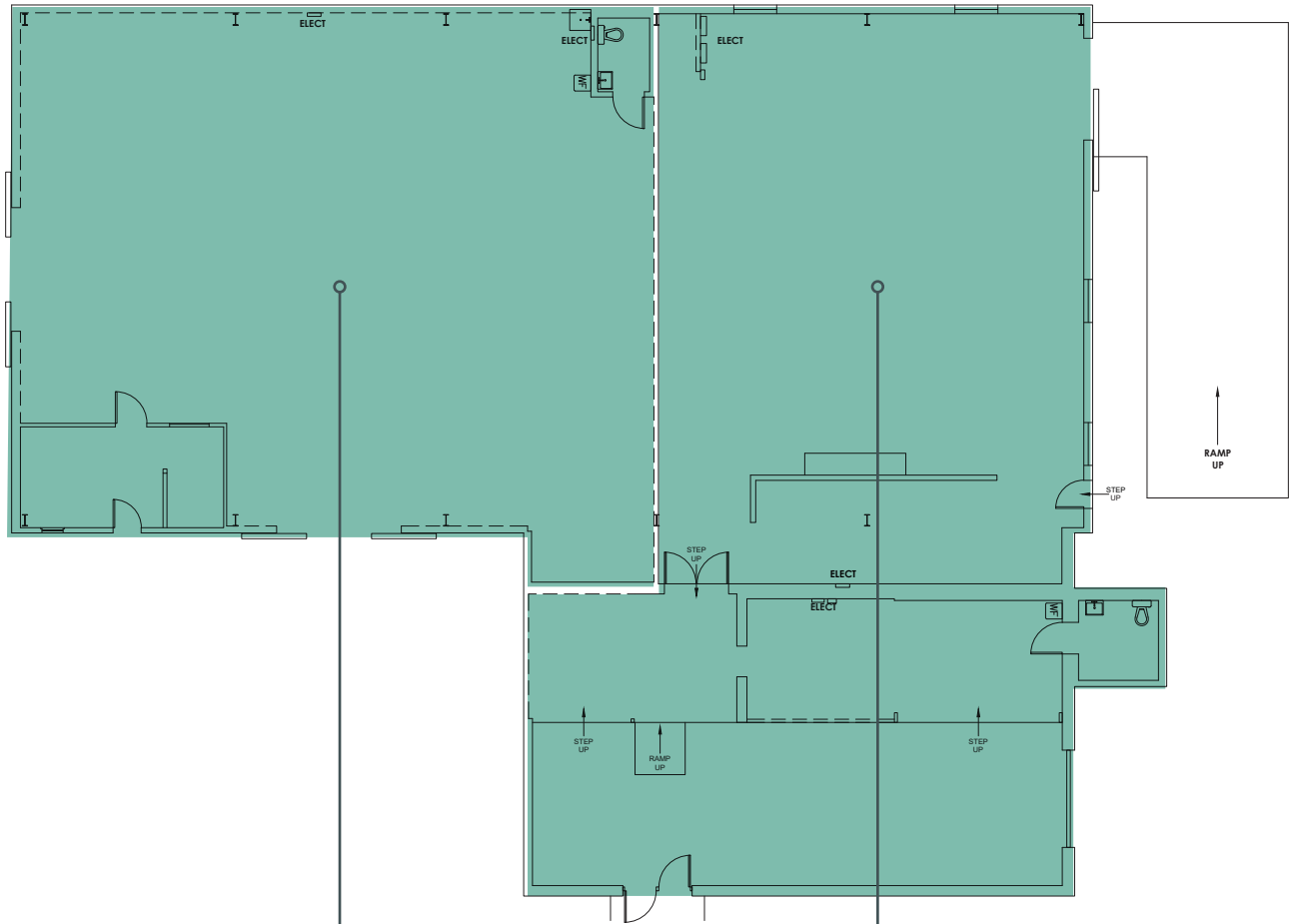

Suite 1

- + 3,136 SF Total
- + 150 SF Office
- + One 12' x 14' Grade Level Door
- + \$4,050.67 per month

Suite 2

- + 3,901 SF Total
- + 0 SF Office (Will BTS)
- + One 12' x 14' Grade Level Door
- + \$5,038.79 per month

Suites 1 & 2

- + 7,037 SF Total
- + 150 SF Office (Will BTS)
- + Two 12' x 14' Grade Level Doors
- + \$9,089.46 per month

Contact Us

Alex Eastwood
850 356 8231

Cameron Thomas
407 404 5078

Jose Rivera (Español)
407 404 5067



1629 Parade Circle

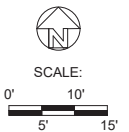
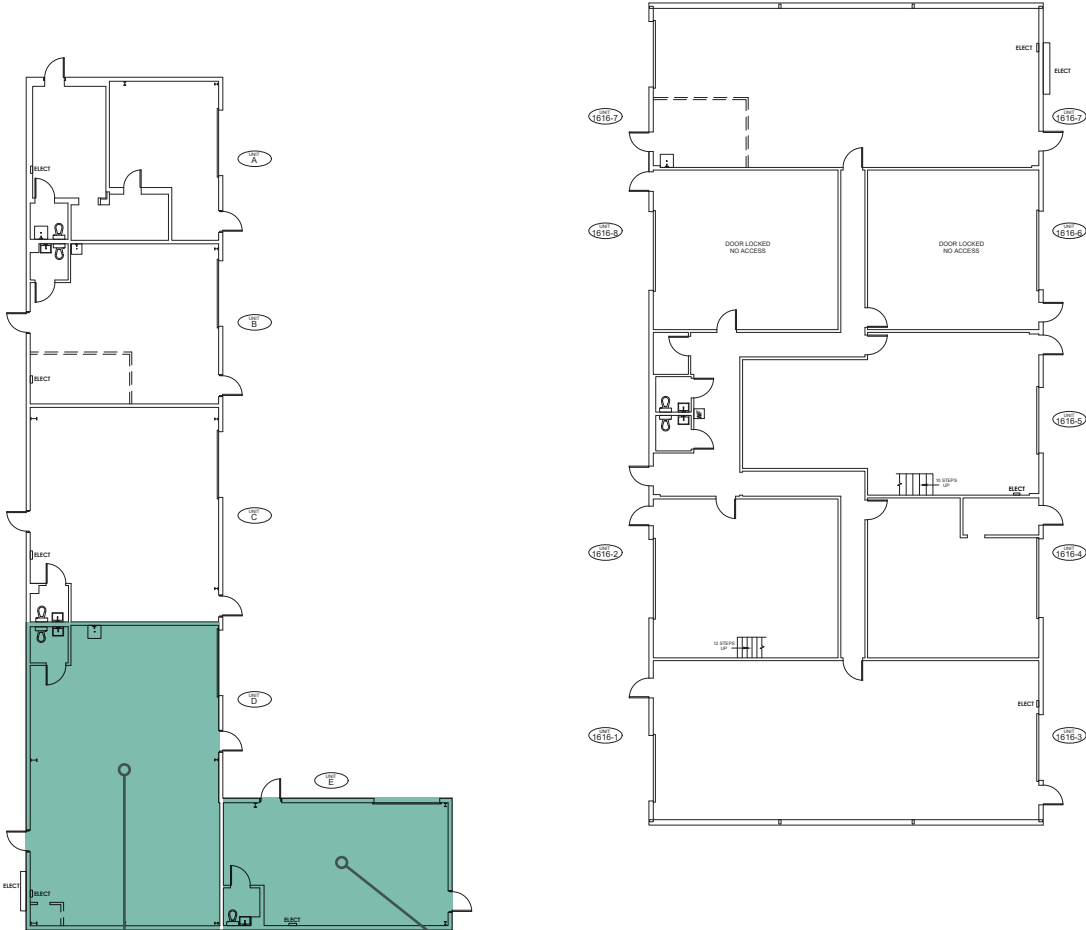

Suite D

- + 1,398 SF Total
- + 0 SF Office
- + One 10' x 10' Grade Level Door
- + \$1,398.00 per month

Suite E

- + 707 SF Total
- + 0 SF Office
- + One 10' x 10' Grade Level Door
- + \$736.46 per month

Suites D & E

- + 2,105 SF Total
- + 0 SF Office
- + Two 10' x 10' Grade Level Doors
- + \$2,280.42 per month

Contact Us

Alex Eastwood
850 356 8231

Cameron Thomas
407 404 5078

Jose Rivera (Español)
407 404 5067



IOS Yards

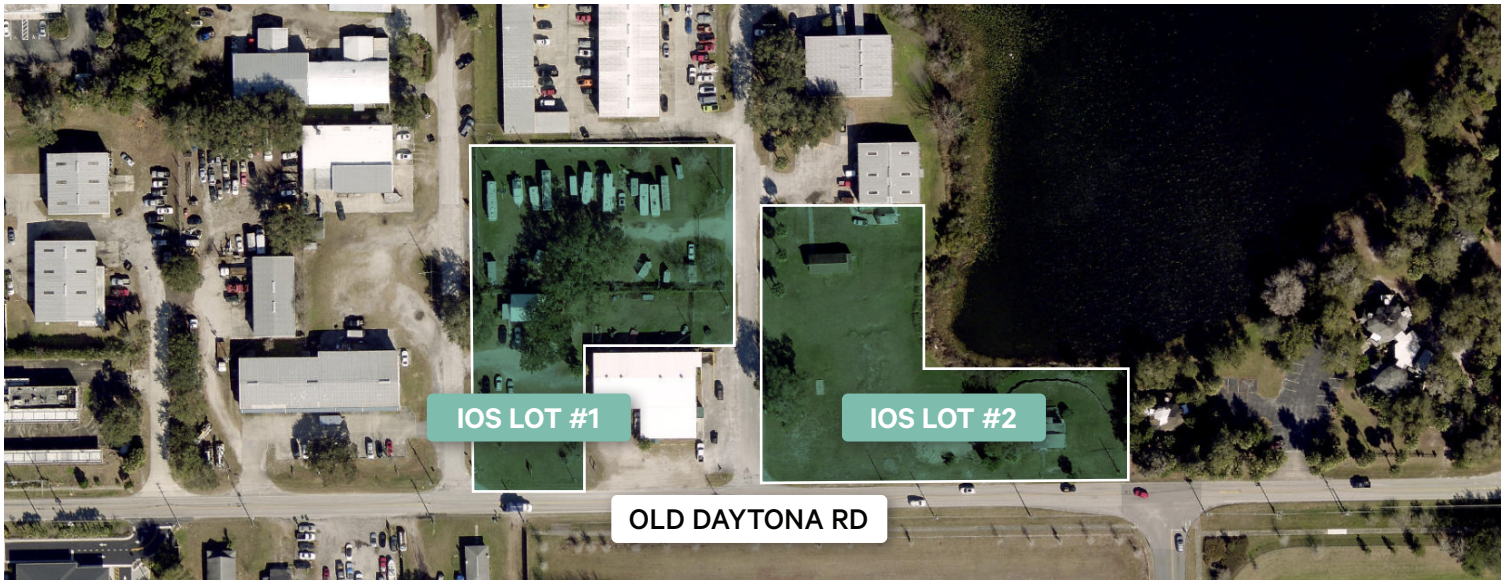
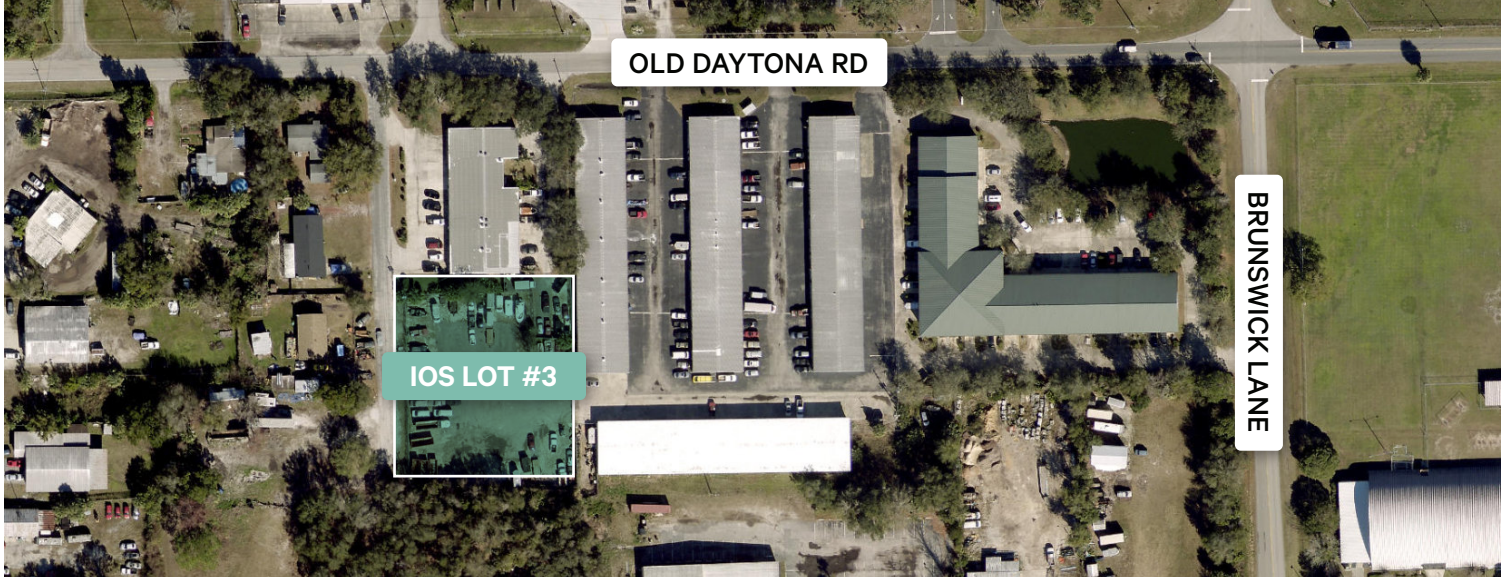

LOT	SIZE	LEASE RATE	DESCRIPTION
#1	1.6 Acres	\$4,800/Month	Able to combine with 207 Old Daytona Road 3,136 – 7,037 SF
#2	1.5 Acres	\$4,500/Month	Able to combine with 1611 Lake Dr – 3,628 SF
#3	0.9 Acres	\$3,000/Month/Acre	Fully fenced/secured and lit

Contact Us

Alex Eastwood
850 356 8231

Cameron Thomas
407 404 5078

Jose Rivera (Español)
407 404 5067

