

GULFPORT RETAIL/OFFICE FOR SALE

1401 49th St S, Gulfport, FL 33707



Sale Price:
\$575,000

Frank Bozikovich
Retail/Land Specialist
Frank@cprteam.com
(727) 501-2844

Highlights



1,965 SF Retail/Office corner property



Former second generation restaurant



Existing grease trap



Great visibility and signage



Traffic Count: 19,100 AADT



No median on 49th street



Drive up 14 parking spaces

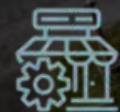

Great for professional office or retail

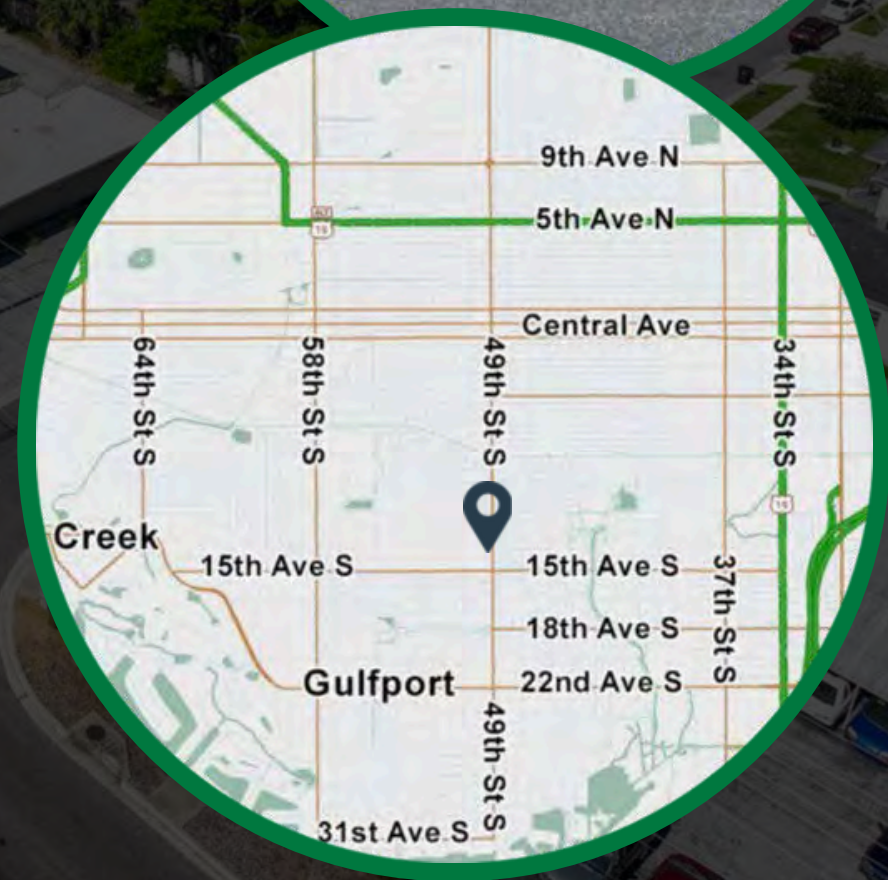

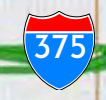
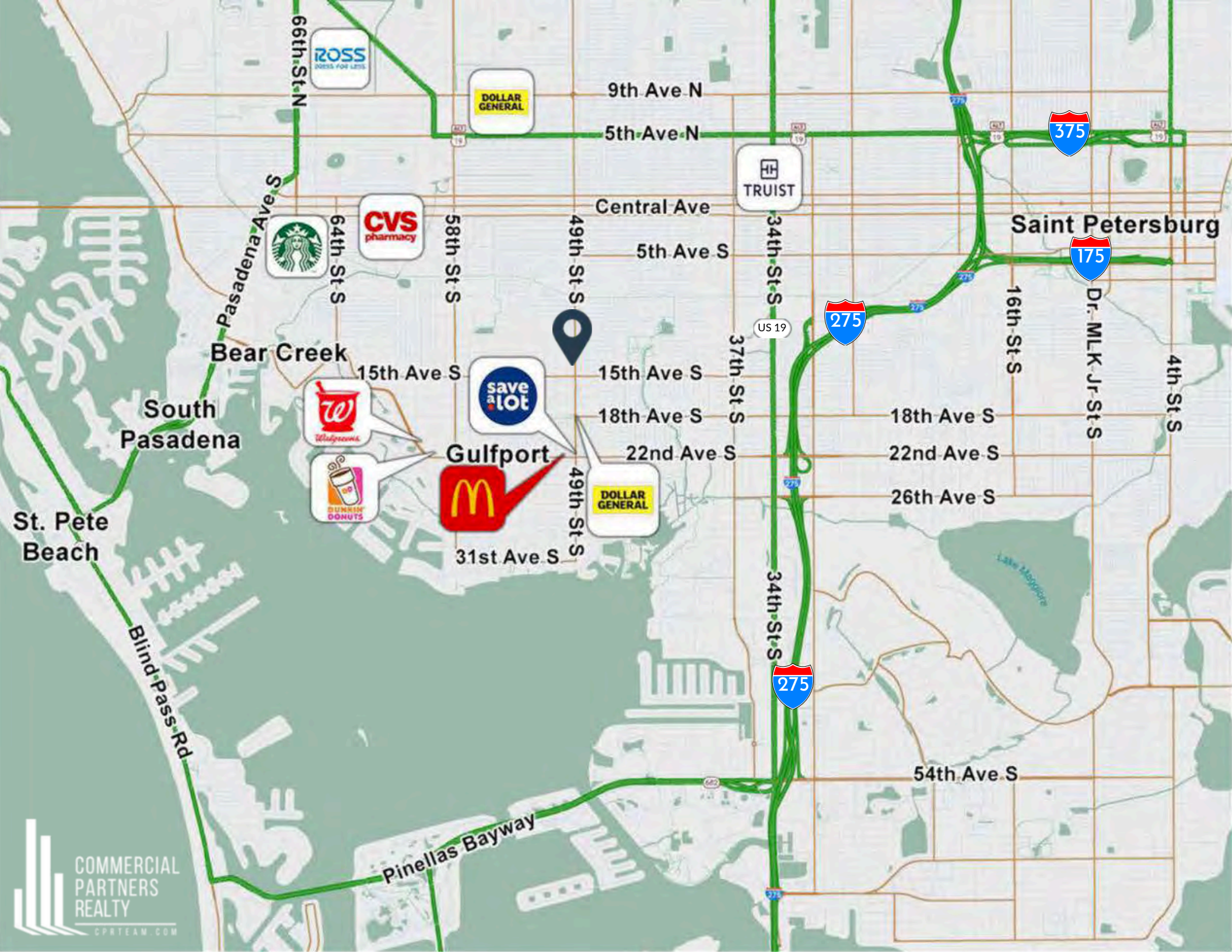

US 19

I-275

I-275



Floor Plan

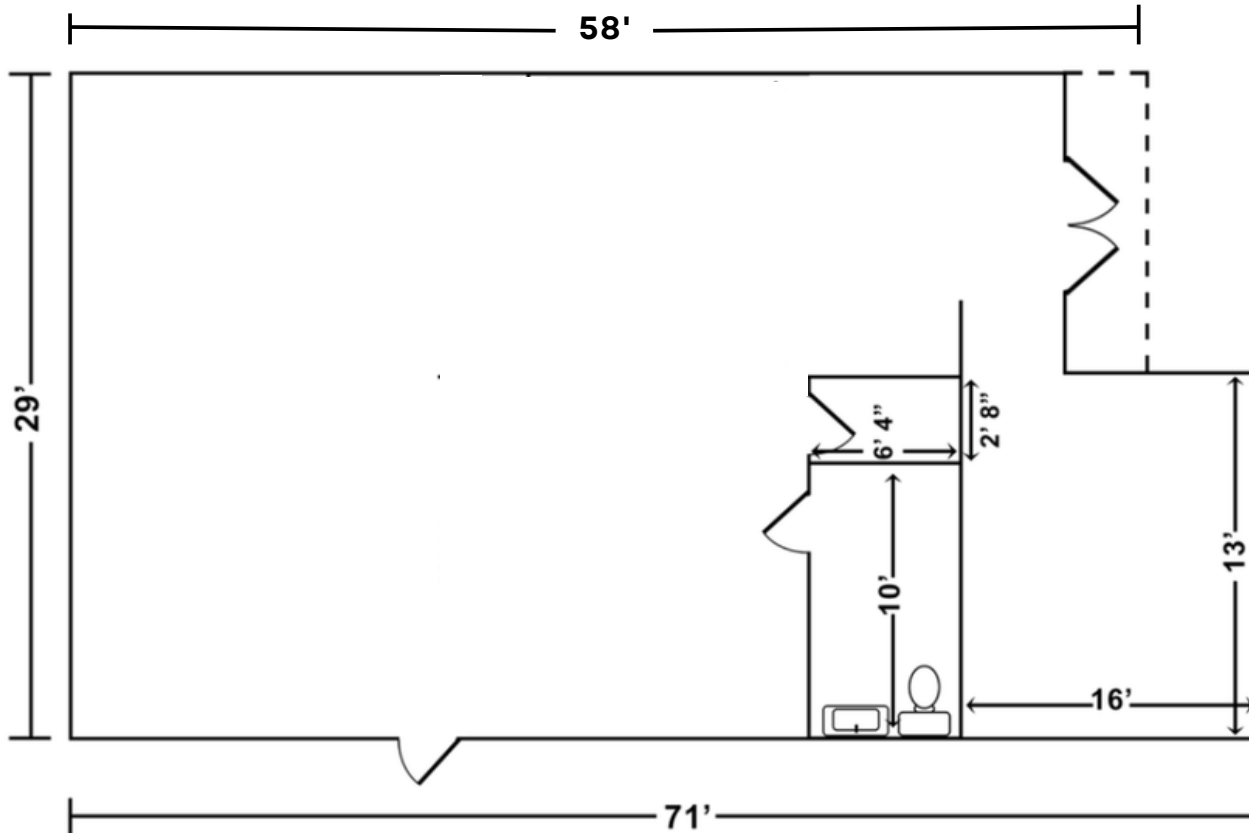

Property Description

1,965 SF of versatile open floor space in this rare retail/Office end cap unit is perfect for your unique concept. Ideal for a beauty parlor, medical office, or retail store, the unit features large picture windows, a grade level double door in the rear, and convenient parking both in front on 49th St and to the side on 14th Ave S. Additionally, it's just 3 miles from I-275, providing easy access for customers and clients.

Listing Agent



Frank is the Retail and Land Specialist for CPR in the Greater Tampa Bay market. Frank guides clients through site location analysis, land assemblage, investment sales and commercial lease negotiations. Throughout his experience, He has worked with many of the nation's 100 largest retailers, the franchise industry, developers, and investors both nationally and locally.

Frank Bozikovich
Retail/Land Specialist
Frank@cprteam.com
(727) 501-2844



www.cprteam.com



[727-822-4715](tel:727-822-4715)



[Commercial Partners Realty](#)