

# INDUSTRIAL SPACE FOR SALE

701 Collins Rd.  
Elkhart, IN



82,452 SF Total Space

10 Acres

For Sale: \$3,995,000



## Property Highlights

- **Total SF: 82,452**
  - 71,468 SF (4,860 SF Office) Main Building
  - 5,984 SF Out Building
  - 5,000 SF Out Building
- **Main Building:**
  - 1,200 Amps 480 V 3 Phase
  - 70' clear span bay running 530' with crane
  - 19 - 14' Grade Level Doors
- **12,000 SF Covered Outdoor Storage (Not included in total SF)**
- **10 Acres Paved and Fenced**
- **Zoned M-1: Light Manufacturing**
- **Taxes 2025, Payable 2026: \$66,874.60**



**Ryan White, CCIM**  
Managing Broker  
574.315.9615  
RWhite@PinnProp.Com

**Pinnacle Properties**  
418 S. Main Street  
Elkhart, IN 46514



Information furnished regarding property for sale, rental or financing is from sources deemed reliable. But no warranty or representation is made as to the accuracy thereof and same is submitted subject to errors, omissions, change of price, rental or other conditions, prior sale, leased, financing or withdrawal without notice. No liability of any kind is to be imposed on the broker herein.



# LOCATION

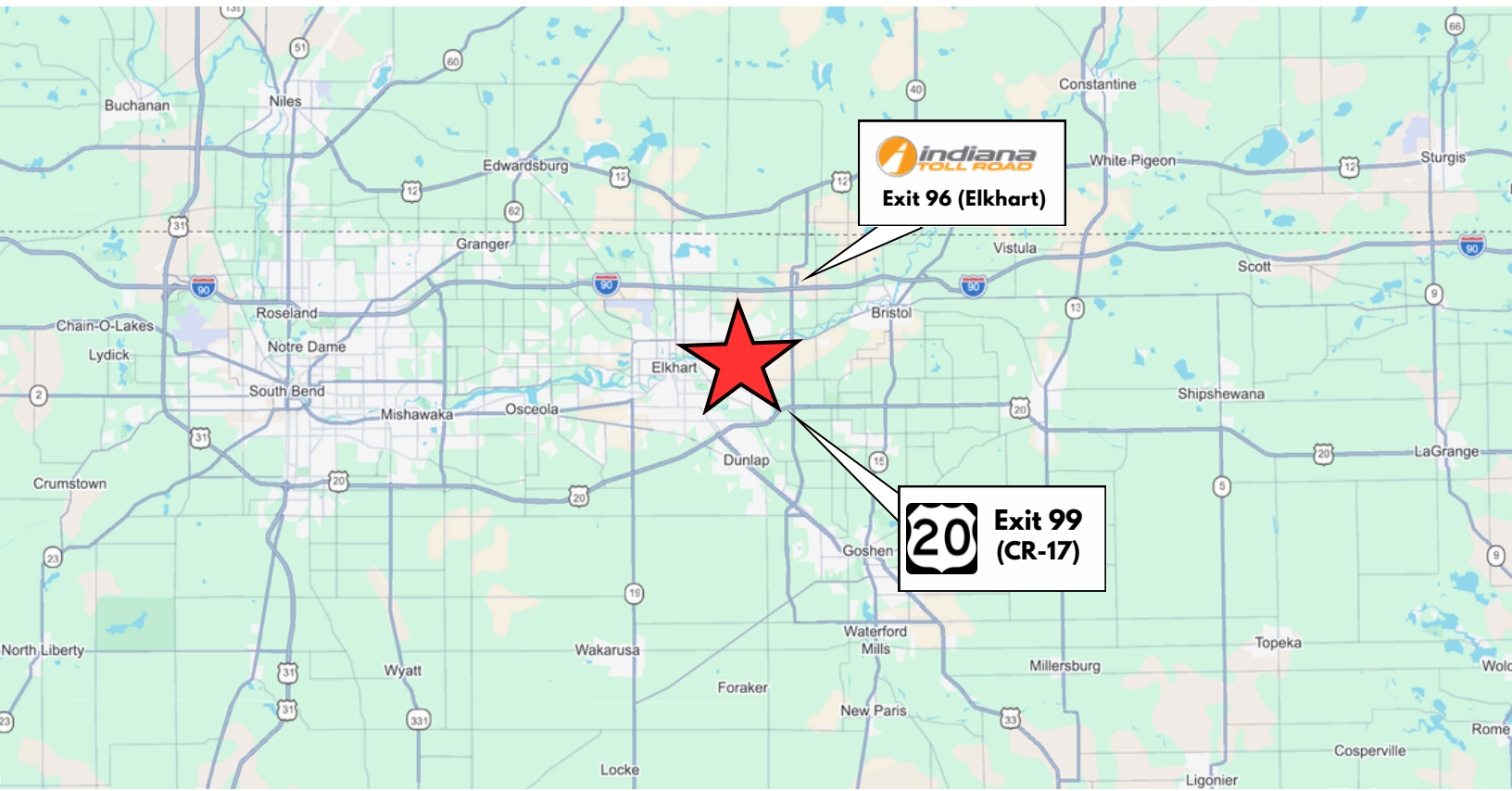



FLOOR PLAN

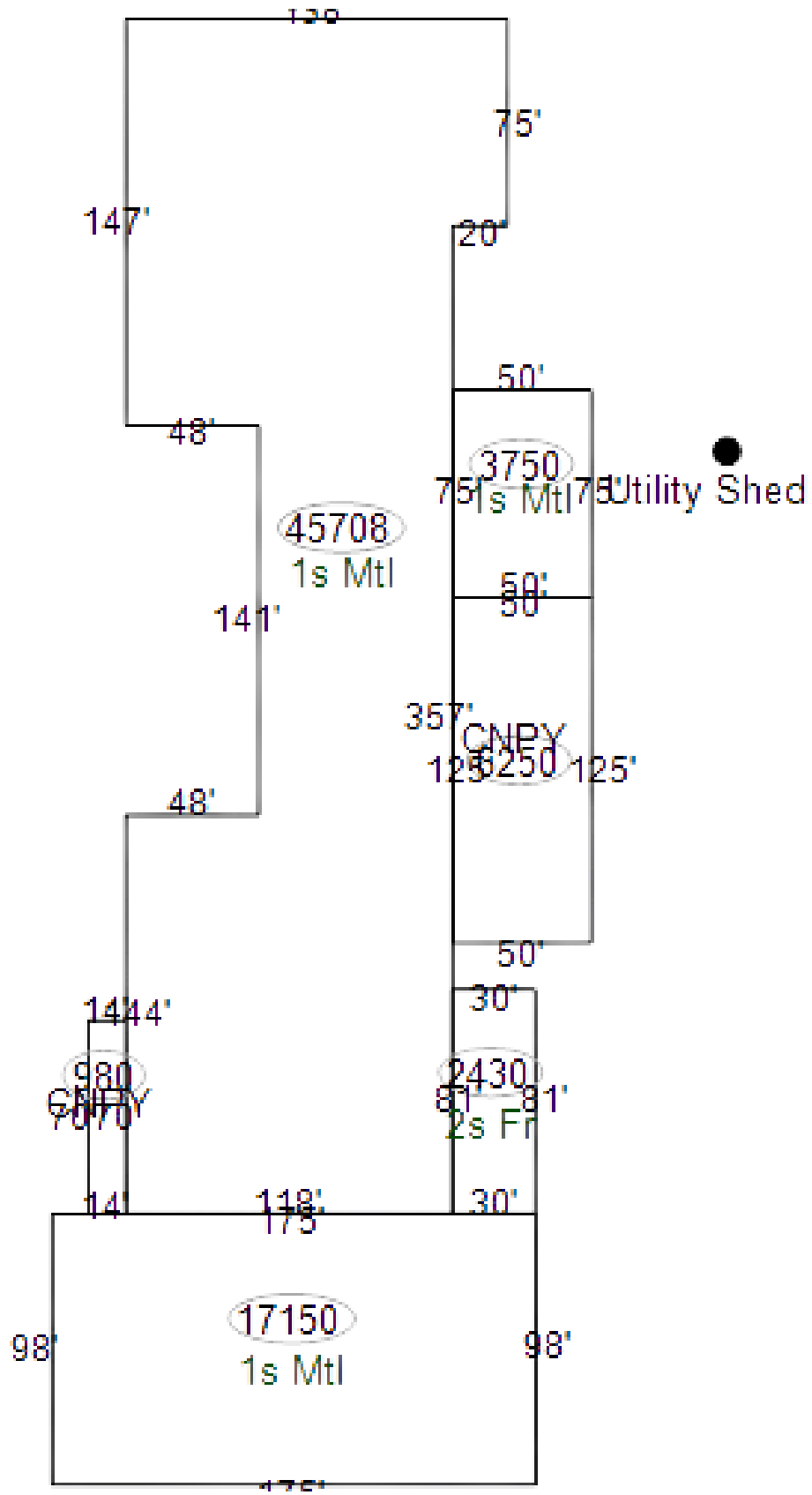



PHOTOS

