

Electrical Information:

Breaker Panel 1:

Service Type: 120/208

Panel Type: Type 1

Panel Number: Not Listed

Manufacturer: Murray Electrical Products

Amps: 200

Location: Stockroom

Exterior Disconnect Information:

Amps: 150

Panel Type: Not Listed

Panel Number: Not Listed

Manufacturer: Not Listed

Location: Side of Unit

Notes: No Label on Exterior Disconnect

Ceiling Information

Height from Floor to Ceiling:

Front: 10' 11" Back: 10' 9"

Floor to Bottom of Deck:

Front: 16' 11" Back: 16' 9"

Floor to Bottom of Joist:

Front: N/A Back: 14' 8"

Notes: Insulation Layer Above Ceiling Tiles

Fire Information:

Riser Location: No Riser in Unit

Sprinkler Heads Present: Yes

Number of Sprinkler Heads: 7

Fire Alarm Control Panel Present: No

Brand: N/A

Model: N/A

Water Heater Information:

Gallons: Tankless

Water Line (in): 3/8"

Manufacturer: Eemax

Model: SP3012

Serial: 848555

Location: Unisex Restroom

Backflow Information:

Number: N/A

Size: N/A

Location:

Notes: No Backflow Preventer Present

HVAC Information:

Unit 1:

Manufacturer: AMERICAN STANDARD

Model: Not Listed

Serial: 852100444L

Tonnage: N/A

Year: 2008

Notes: Label is Faded

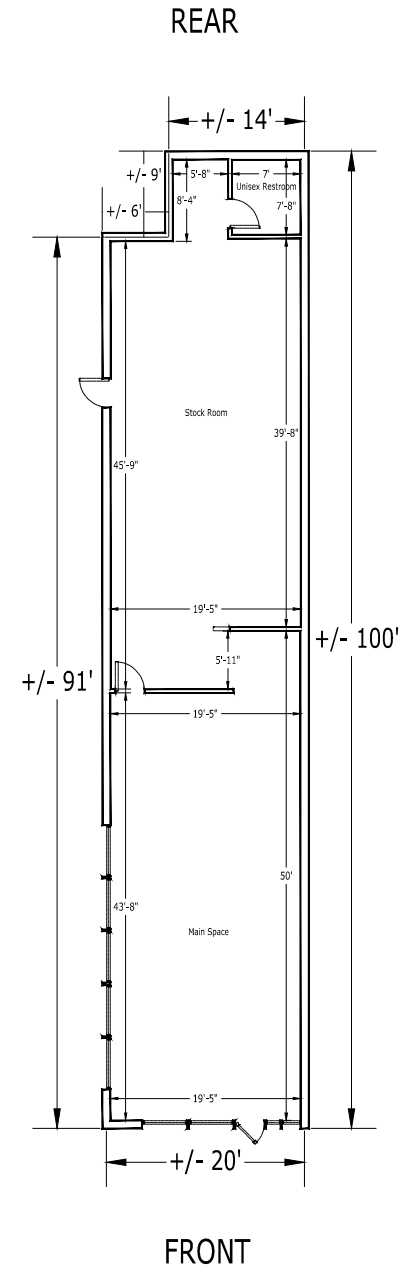

1 MAIN FLOOR

Park North

Unit T05C
834 Northwest Loop #10
Suite 101
San Antonio, TX 78216



Sterling Organization
340 Boyd Parkway Way
Suite 316
Ft. Worth, TX 76109

Unit T05C
+/- 1,946 SF

Square footage shown was measured on field and differs to BOMA standard

Width
+/- 20'
Depth
+/- 100'

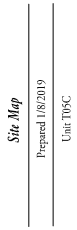
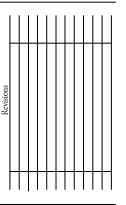

Siz Map
Prepared 1/8/2019
Unit T05C

Plans produced by:
ID Plans

400 N. Tampa St, Suite 2210
Tampa, FL 33603
Phone: (888) 871-2145
IDPlans.com



Site Map is for general use and does not constitute a contract. ID Plans does not guarantee the existence or validity of provided information. Measurements are not intended to be comprehensive and are subject to change without notice. No responsibility is assumed for omissions, errors, or misstatements or changes to be made to the drawings. Each set of drawings is the property of ID Plans and contains the right and responsibility to verify, change, or alter the provided information at any time for any reason.

SPACE PROFILE
FOR

Park North

Unit # T05C
1,946 Square Feet



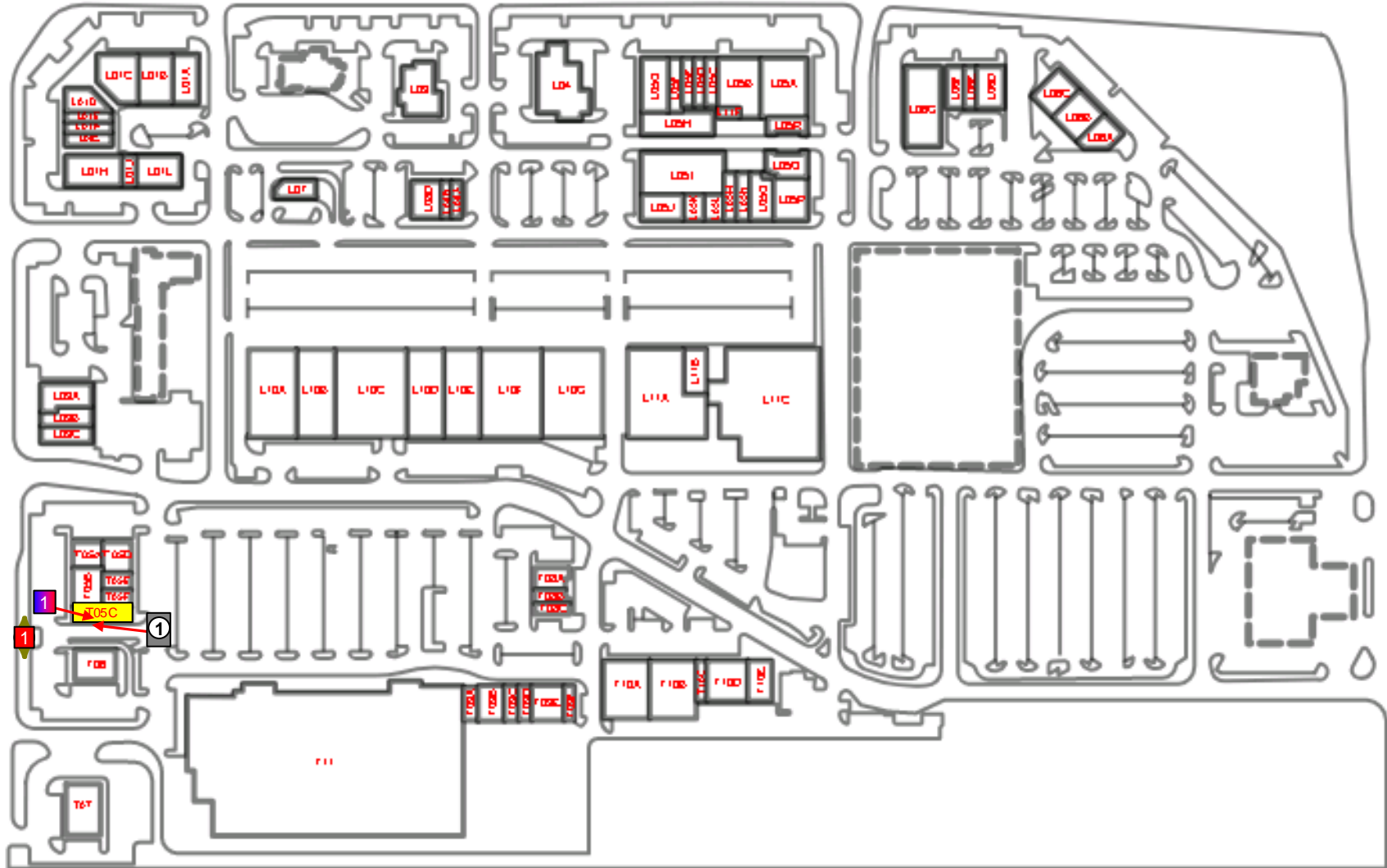

Reference #

Meter #

Electric



6144939

Water
(House Meter)



7364537

HVAC Units & Information

Unit #	Space #	Manufacturer	Model #	Tonnage	Serial #	Year
1	T05C	AMERICAN STANDARD	UNREADABLE	N/A	852100444L	2008

Plans produced by:

















































ID Plans

1/9/2019

(813) 657-2545



Legend

	Breaker Panel		Fire Extinguisher		Maintenance Sink		Window
	Circular Column		Fire Alarm Pulldown		Ceiling Fan w/Light		Fire Sprinkler
	Appliance Outlet		Glass Door		Rectangular Column		Pocket Door
	Fire Alarm		Handicap Handrail		Refrigerator		Track Lighting
	Drinking Fountain		Roof Hatch		Roll-Up Door		2-Bulb Fluorescent Lighting
	Door		HVAC Unit		Sink		3-Bulb Fluorescent Lighting
	Double Hung		Recessed Light		Swing Door		4-Bulb Fluorescent Lighting
	Electrical Outlet		Staircase		Toilet		Ceiling Air Vent
	Emergency Light		Joist Girder Direction		Can Light		Air Diffuser
	Exit Light		Water Heater		Urinal		Ceiling Fan without Light
	Tankless Water Heater		Telephone Panel		Thermostat		Air Handler
	Step Down Transformer		Window Wall Opening		RJ 45		Fire Alarm Control Panel
	Disconnect						

Disclaimer: All items may not show on feature pages.

Plans produced by:

ID Plans

1/7/2019

(813) 657-2545

ID PLANS

© 2019

Detail Plan

Park North Unit # T05C

