

PARCEL NO. 531-011-01

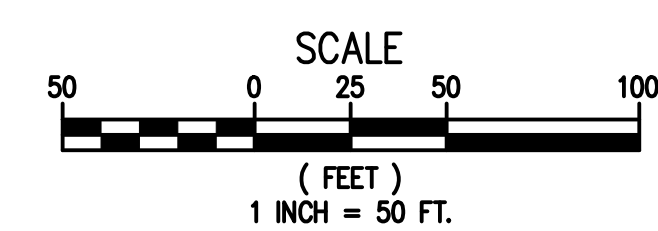
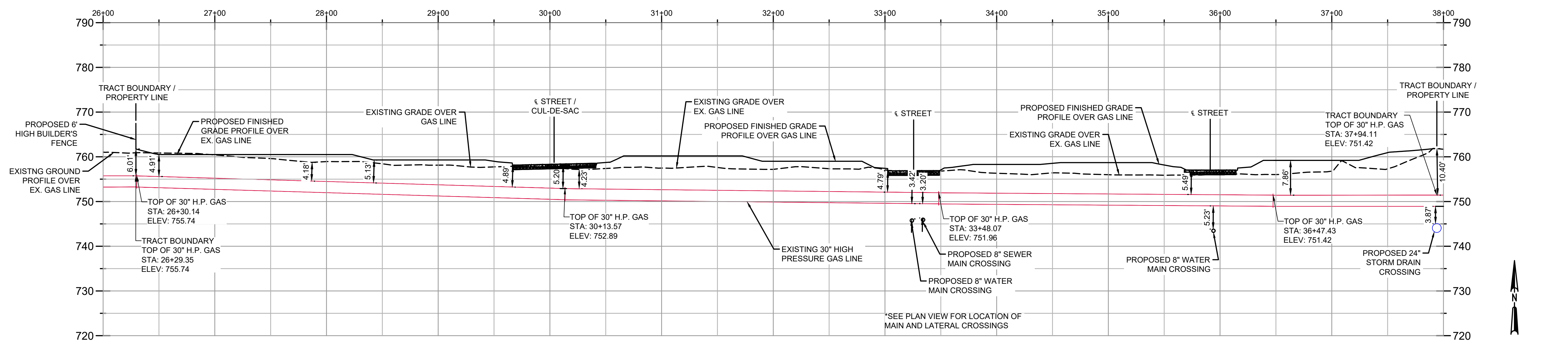
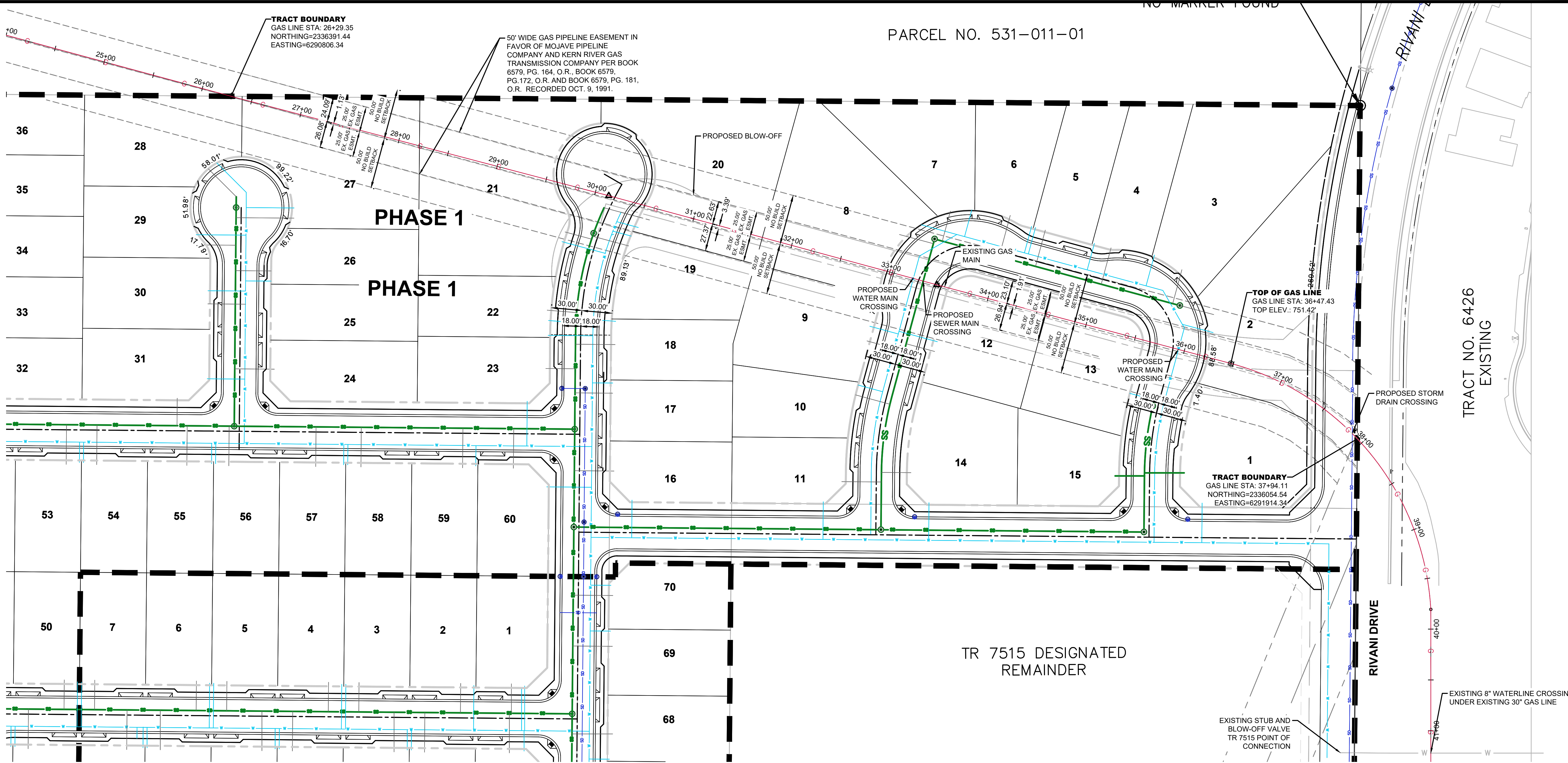

TTM 7515
MOJAVE PIPELINE
EXHIBIT

Authority
Engineering
Surveying
AES
Civil Engineering | Land Surveying | Planning

REVIEWED BY: _____
DATE: _____
REVISION: _____

APPROVED BY: NG
CHECKED BY: NG
DRAWN BY: BNR

PROJECT NO. 25-019
SHEET NO. 1 OF 4

REGISTERED PROFESSIONAL ENGINEER
N. CANDRO GALZA
C 96294
CIVIL
STATE OF CALIFORNIA

1.0

Plot Date: 3/27/2026 2:51 AM

PARCEL NO. 531-011-01

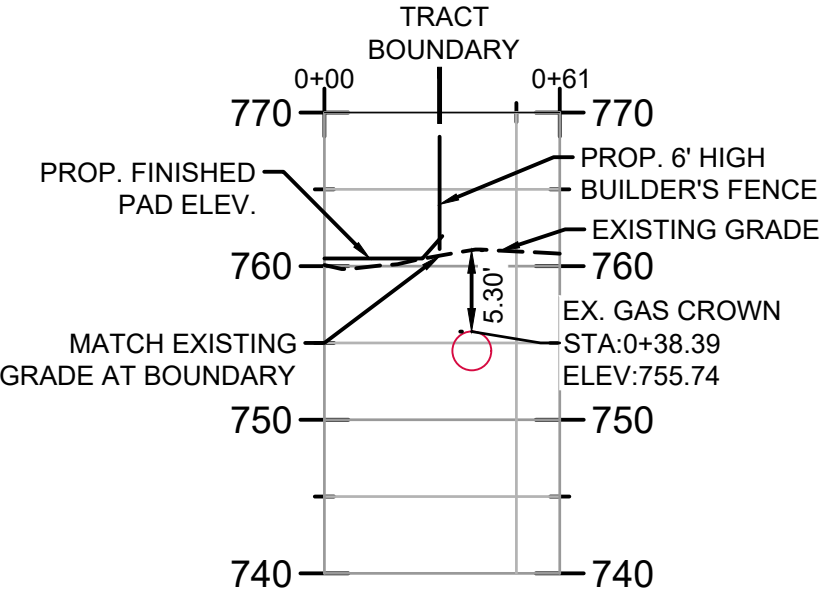
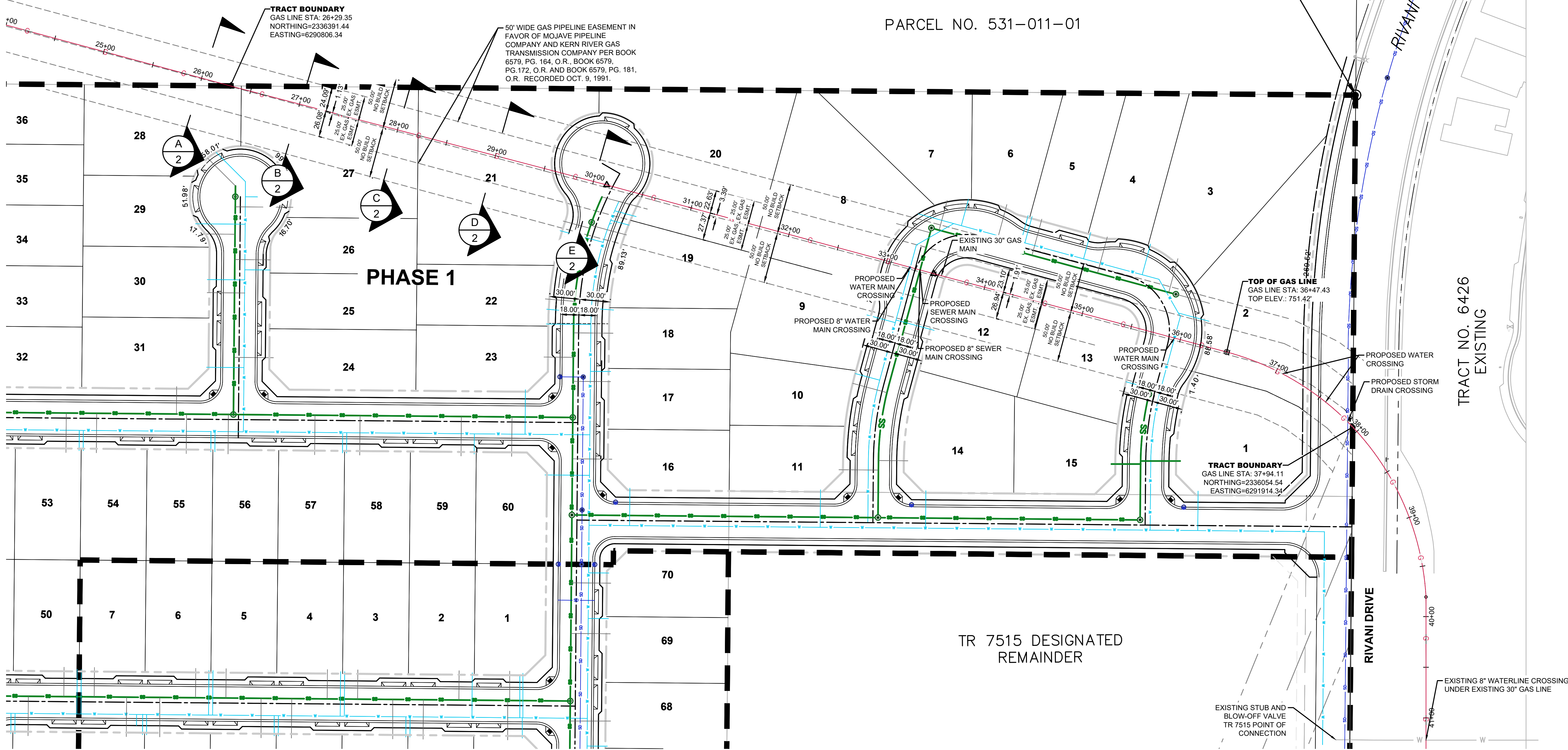

CROSS SECTION @ STA. 26+00
SCALE: N.T.S.

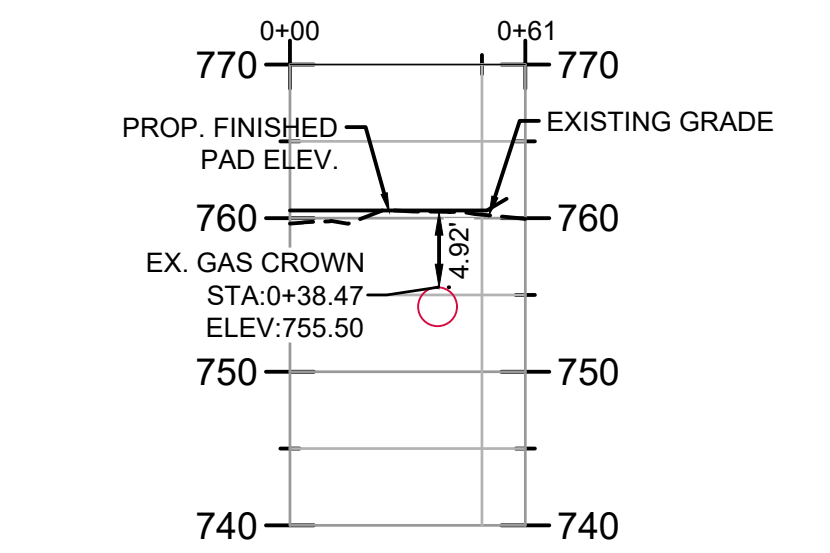

CROSS SECTION @ STA. 27+00
SCALE: N.T.S.

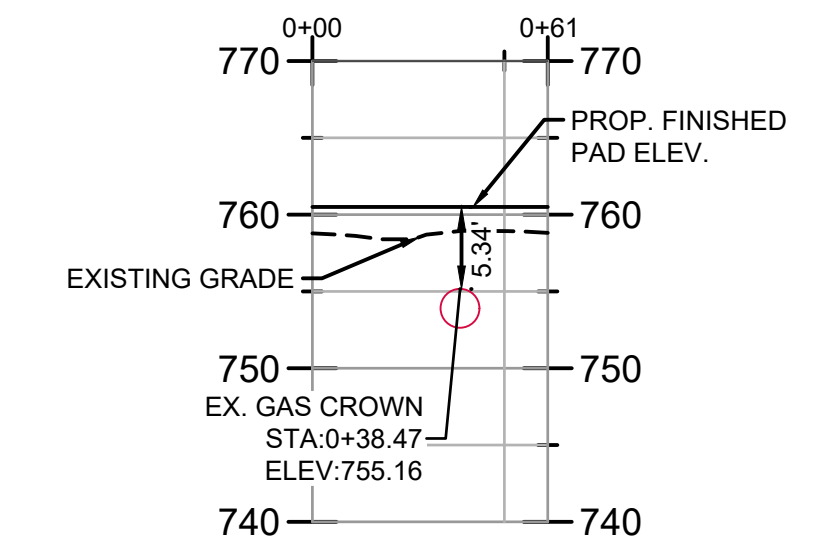

CROSS SECTION @ STA. 28+00
SCALE: N.T.S.

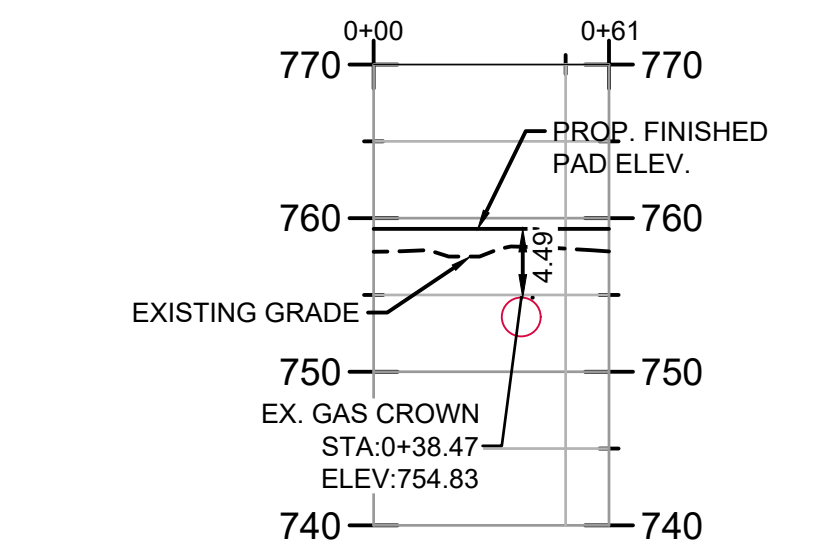

CROSS SECTION @ STA. 29+00
SCALE: N.T.S.

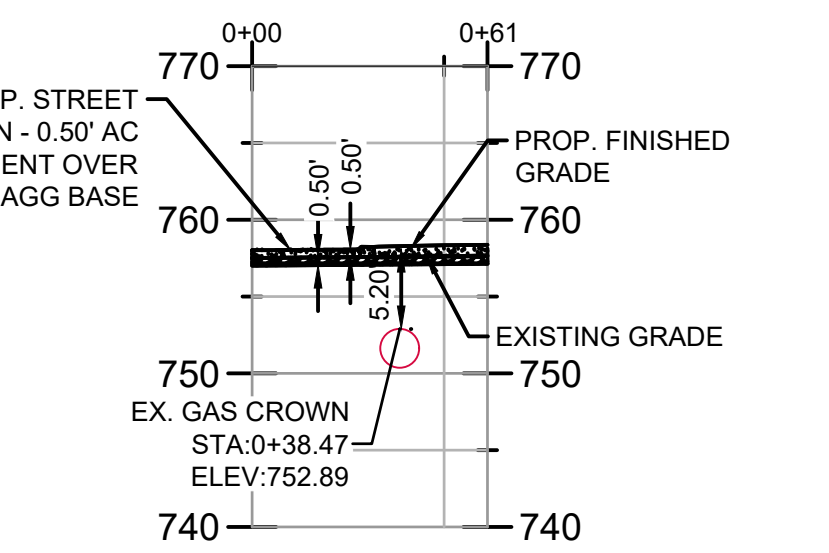

CROSS SECTION @ STA. 30+00
SCALE: N.T.S.

LEGEND	
PROPOSED FEATURES	
	PROPOSED BLOW-OFF
	PROPOSED FIRE HYDRANT
	PROPOSED WATER METER
	PROPOSED SEWER MANHOLE
	PROPOSED MONUMENT
	PROPOSED DRIVEWAY
	PROPOSED WATER MAIN
	PROPOSED WATER LATERAL
	PROPOSED STORM DRAIN
	PROPOSED SEWER MAIN
	PROPOSED SEWER SERVICE
	PROPOSED LOT LINE
	PROPOSED GAS LINE
	PROPOSED ELECTRICAL LINE

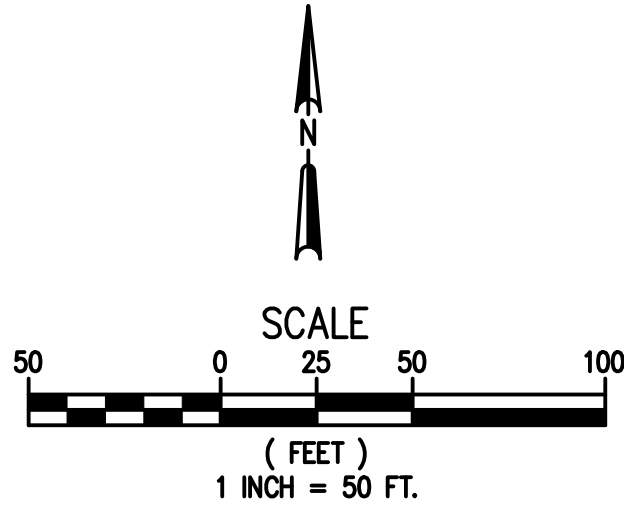

TTM 7515

MOJAVE PIPELINE EXHIBIT

AUTHORITY
 ENGINEERING
 SURVEYING
AES
 CIVIL ENGINEERING | LAND SURVEYING | PLANNING

REVIEWED BY: _____
 NO. DATE REVISION



APPROVED BY: NG
 CHECKED BY: NG
 DRAWN BY: BNR

PROJECT NO. 25-019

SHEET NO. 2 OF 4

2.0

Plot Date: 3/27/2026 2:52 AM

PARCEL NO. 531-011-01

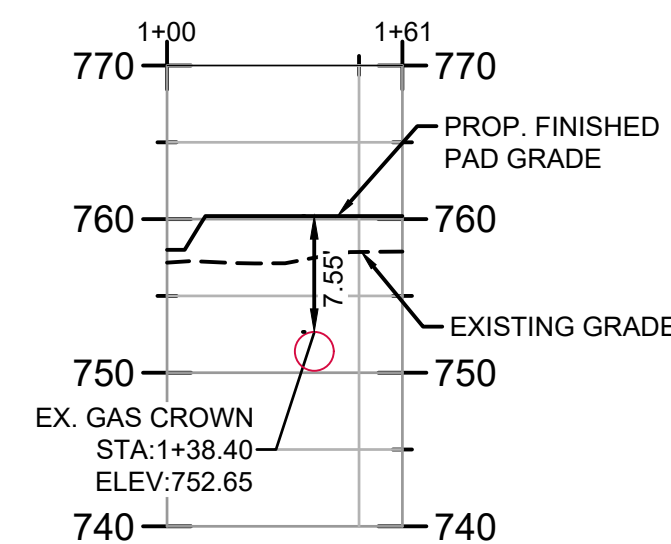
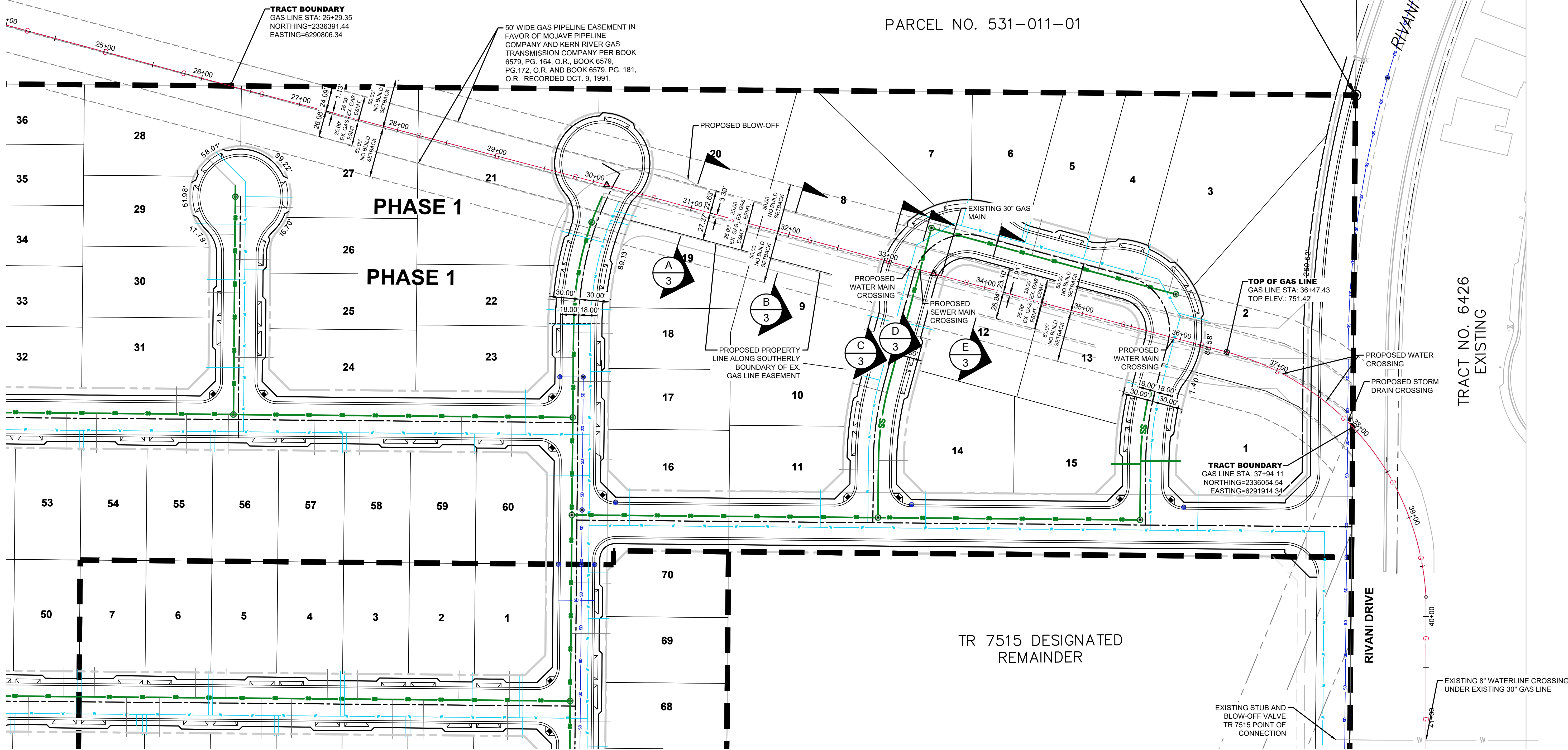

A
3

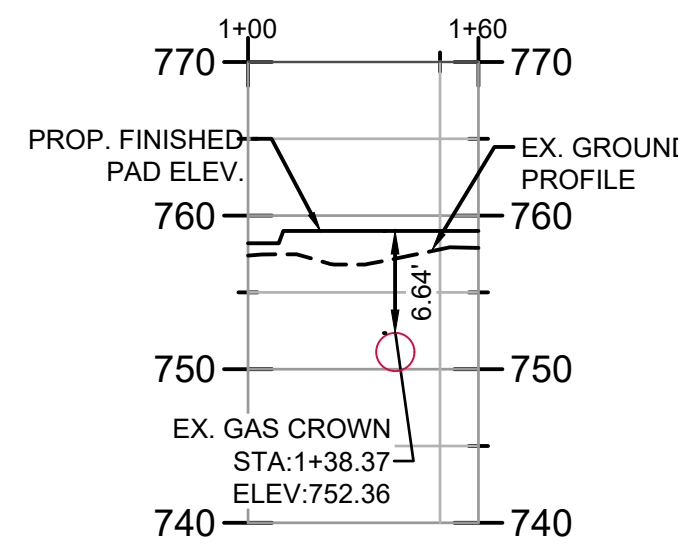

B
3

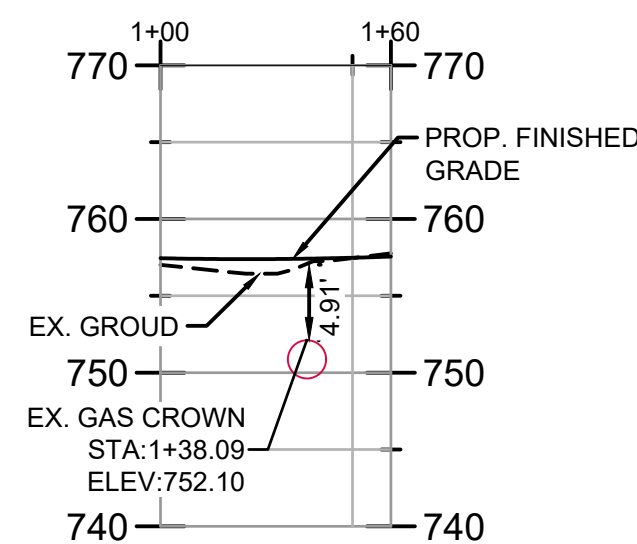

C
3

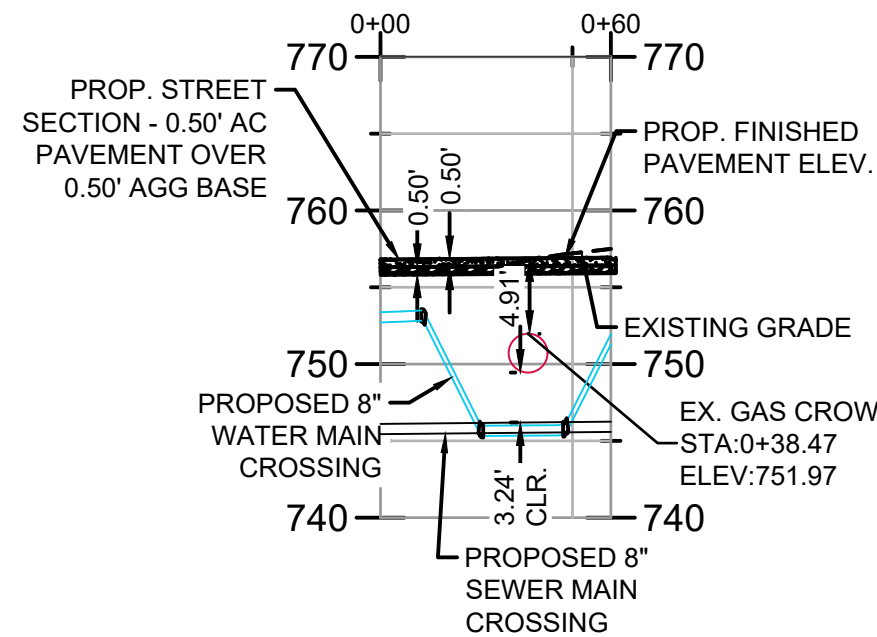

D
3

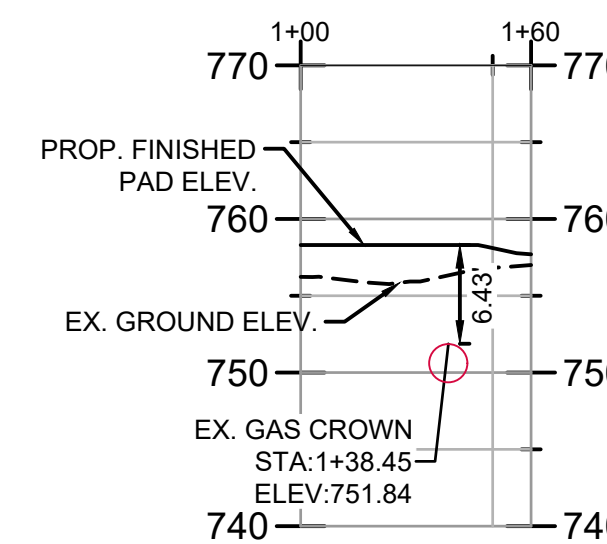

E
3

LEGEND	
PROPOSED FEATURES	
	PROPOSED BLOW-OFF
	PROPOSED FIRE HYDRANT
	PROPOSED WATER METER
	PROPOSED SEWER MANHOLE
	PROPOSED MONUMENT
	PROPOSED DRIVEWAY
	PROPOSED WATER MAIN
	PROPOSED WATER LATERAL
	PROPOSED STORM DRAIN
	PROPOSED SEWER MAIN
	PROPOSED SEWER SERVICE
	PROPOSED LOT LINE
	PROPOSED GAS LINE
	PROPOSED ELECTRICAL LINE

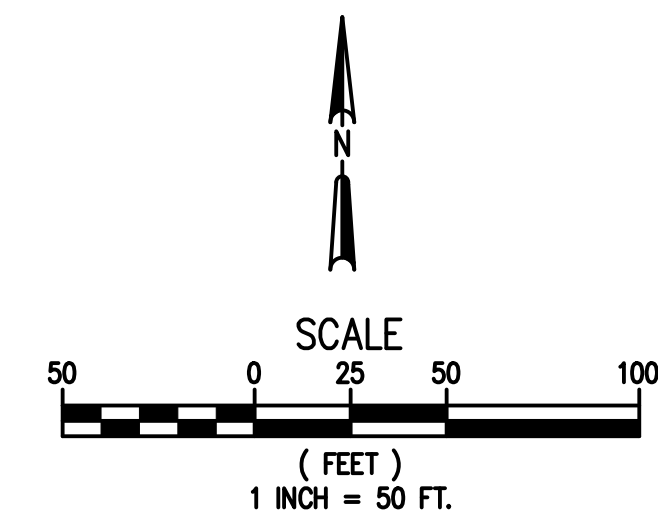

TTM 7515

MOJAVE PIPELINE
EXHIBIT

AES
AUTHORITY
ENGINEERING
SURVEYING
CIVIL ENGINEERING | LAND SURVEYING | PLANNING

REVIEWED BY: []
DATE: []
REVISION: []



APPROVED BY: NG
CHECKED BY: NG
DRAWN BY: BNR

PROJECT NO. 25-019

SHEET NO. 3 OF 4

3.0

Plot Date: 3/27/2026 2:55 AM

PARCEL NO. 531-011-01

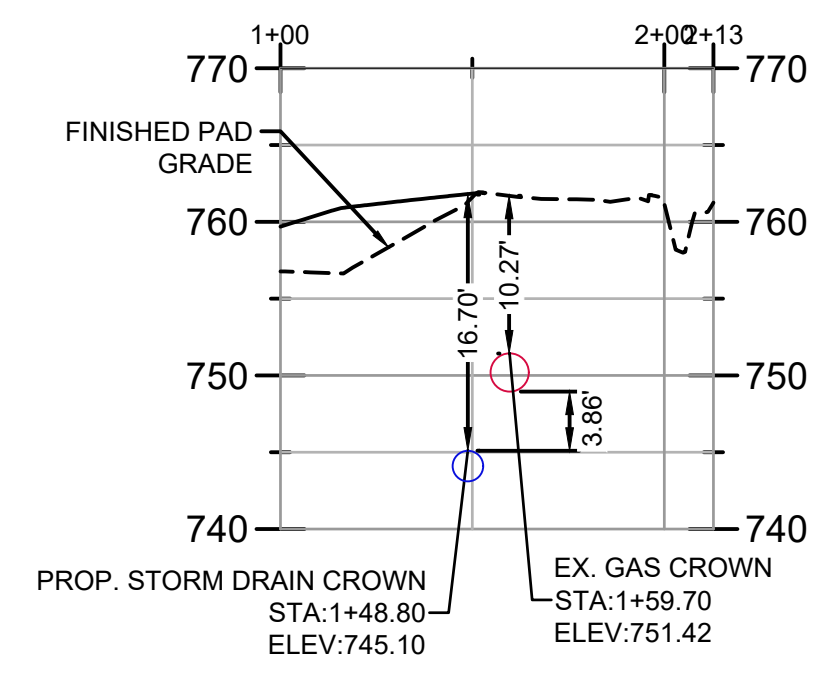
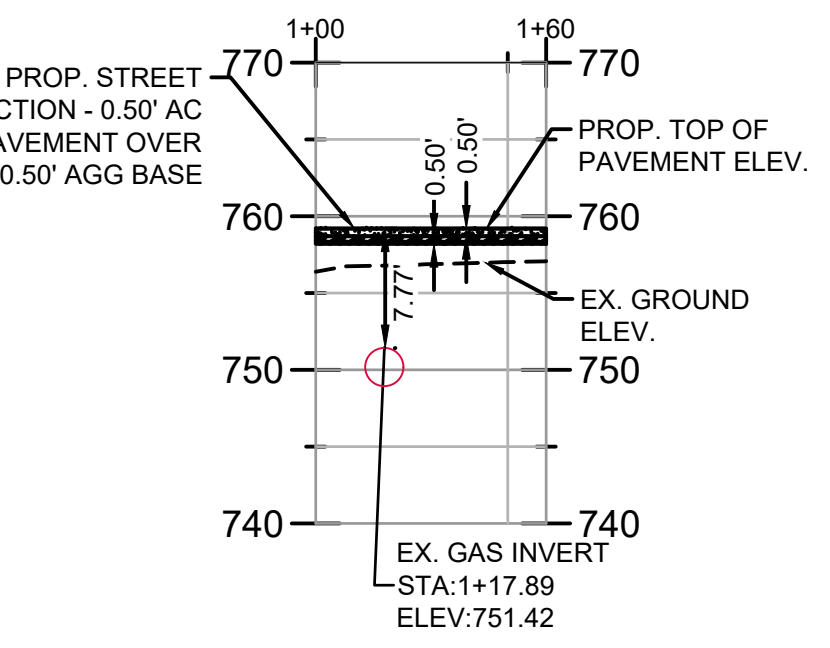
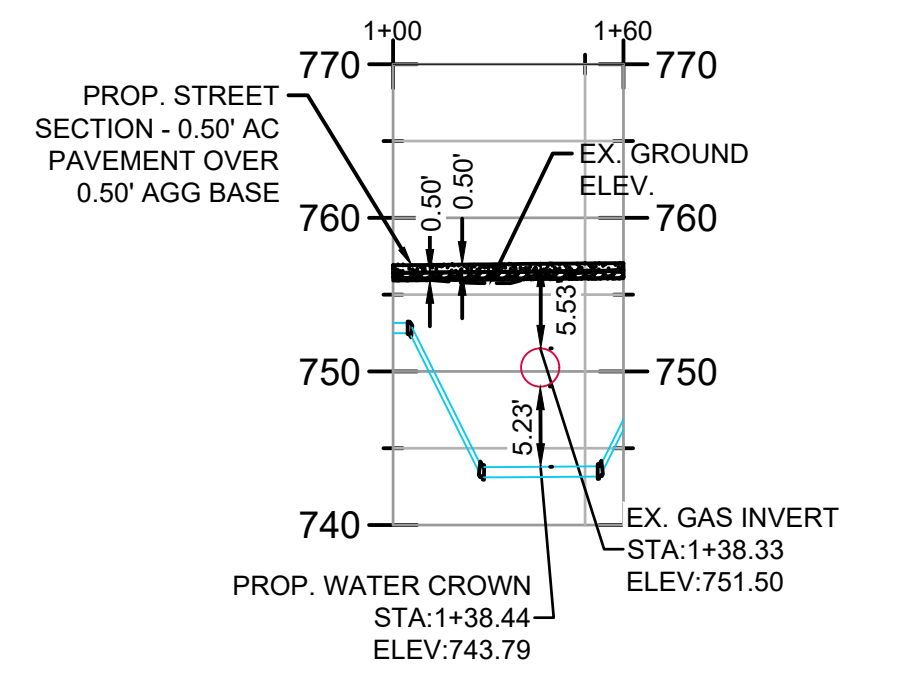
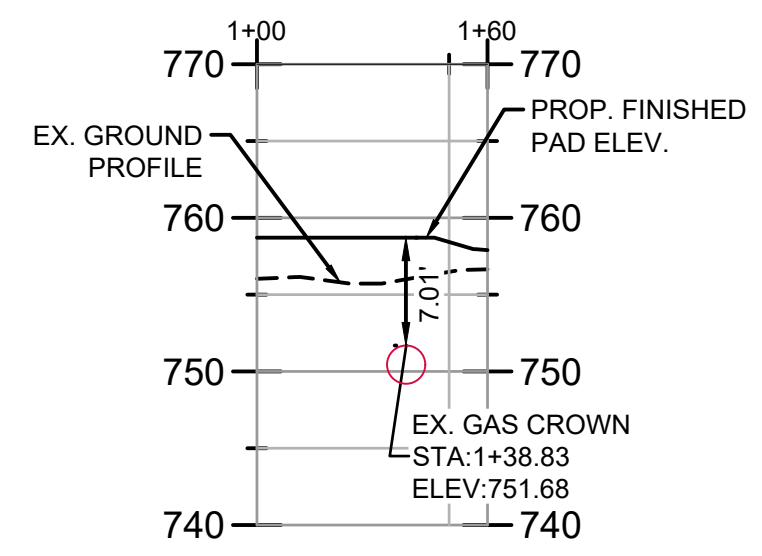
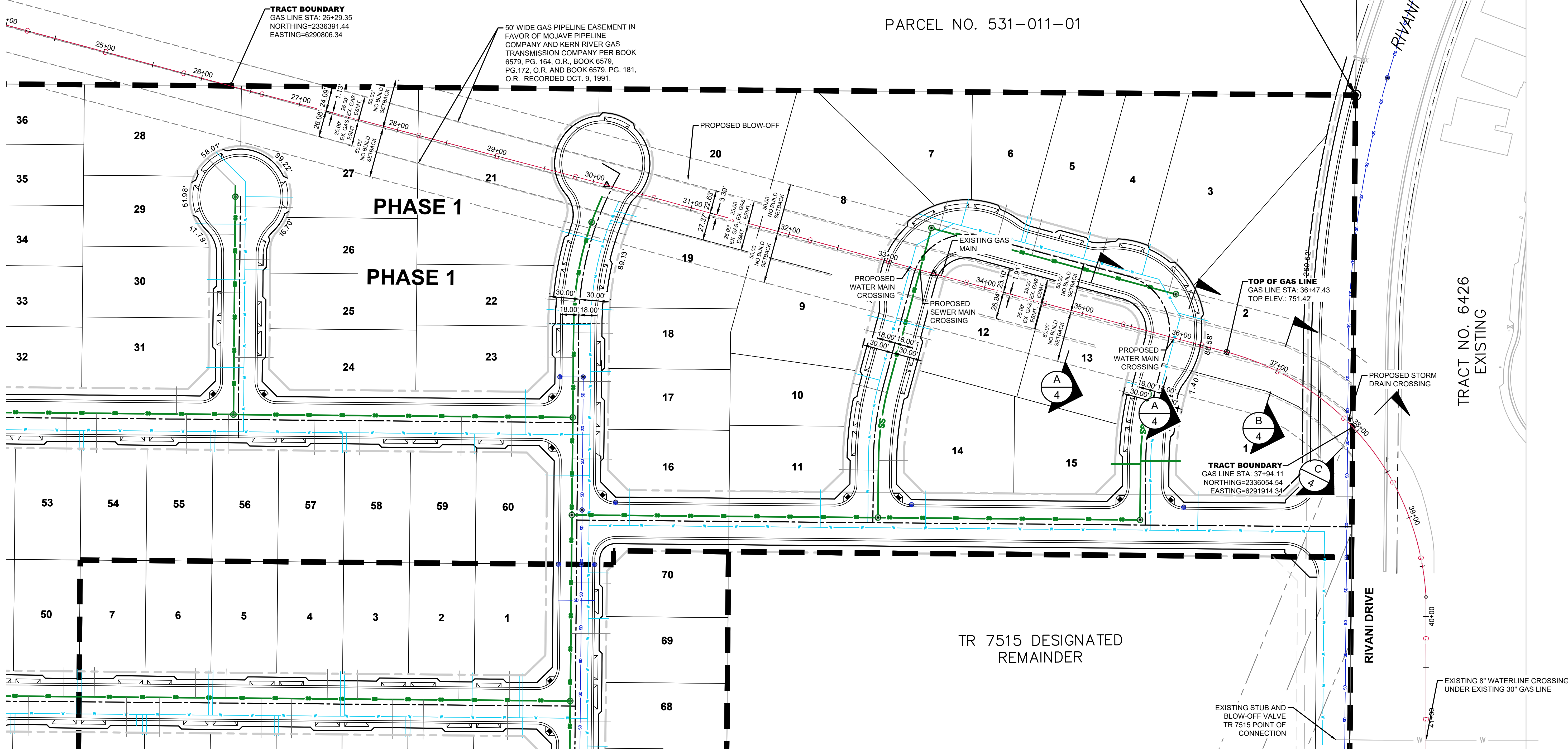

LEGEND	
PROPOSED FEATURES	
	PROPOSED BLOW-OFF
	PROPOSED FIRE HYDRANT
	PROPOSED WATER METER
	PROPOSED SEWER MANHOLE
	PROPOSED MONUMENT
	PROPOSED DRIVEWAY
	PROPOSED WATER MAIN
	PROPOSED WATER LATERAL
	PROPOSED STORM DRAIN
	PROPOSED SEWER MAIN
	PROPOSED SEWER SERVICE
	PROPOSED LOT LINE
	PROPOSED GAS LINE
	PROPOSED ELECTRICAL LINE

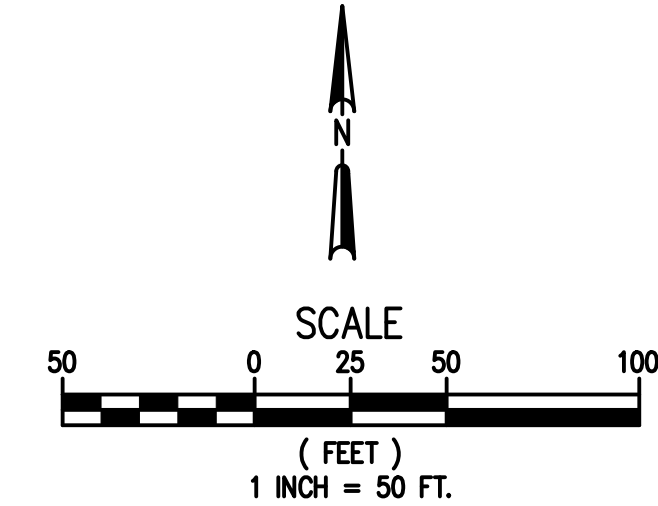

TTM 7515

MOJAVE PIPELINE EXHIBIT

AUTHORITY
 ENGINEERING
 SURVEYING
AES
 CIVIL ENGINEERING | LAND SURVEYING | PLANNING

REVIEWED BY: _____
 NOT DATE: _____
 REVISION: _____



APPROVED BY: NG
 CHECKED BY: NG
 DRAWN BY: BNR

PROJECT NO. 25-019

SHEET NO. 4 OF 4

4.0

Plot Date: 3/27/2026 2:55 AM