



## 601 South 3rd St. West

Missoula, MT 59801

### Property Features

- Approximately 1,200 sf. available.
- \$40.00 psf/yr. plus gas, water & electric.
- 3% annual increase.
- NNN = \$8.05
- 3 to 5 year lease term.
- Parking shared with apartments behind the building.
- One private office, restroom, break room, and large open workspace.
- Basement storage.

### Amentities

The building offers excellent visibility on South 3rd St. West, a main thoroughfare from downtown to Reserve Street. The building is constructed of brick and block with timeless appeal. This building would be great as an office space as well as small retail space.



**Jeff L Moore**

+1 406 721 1111 • [jeff@naicrowleymoore.com](mailto:jeff@naicrowleymoore.com)

# For Lease

1,200 SF

Excellent Retail or Office Space



111 North Higgins Avenue  
Missoula, Montana 59802  
+1 406 721 1111  
naicrowleymoore.com

# For Lease

## 1,200 SF

### Excellent Retail or Office Space

#### Detail Images of the Space



# For Lease

1,200 SF

Excellent Retail or Office Space

## Floor plan

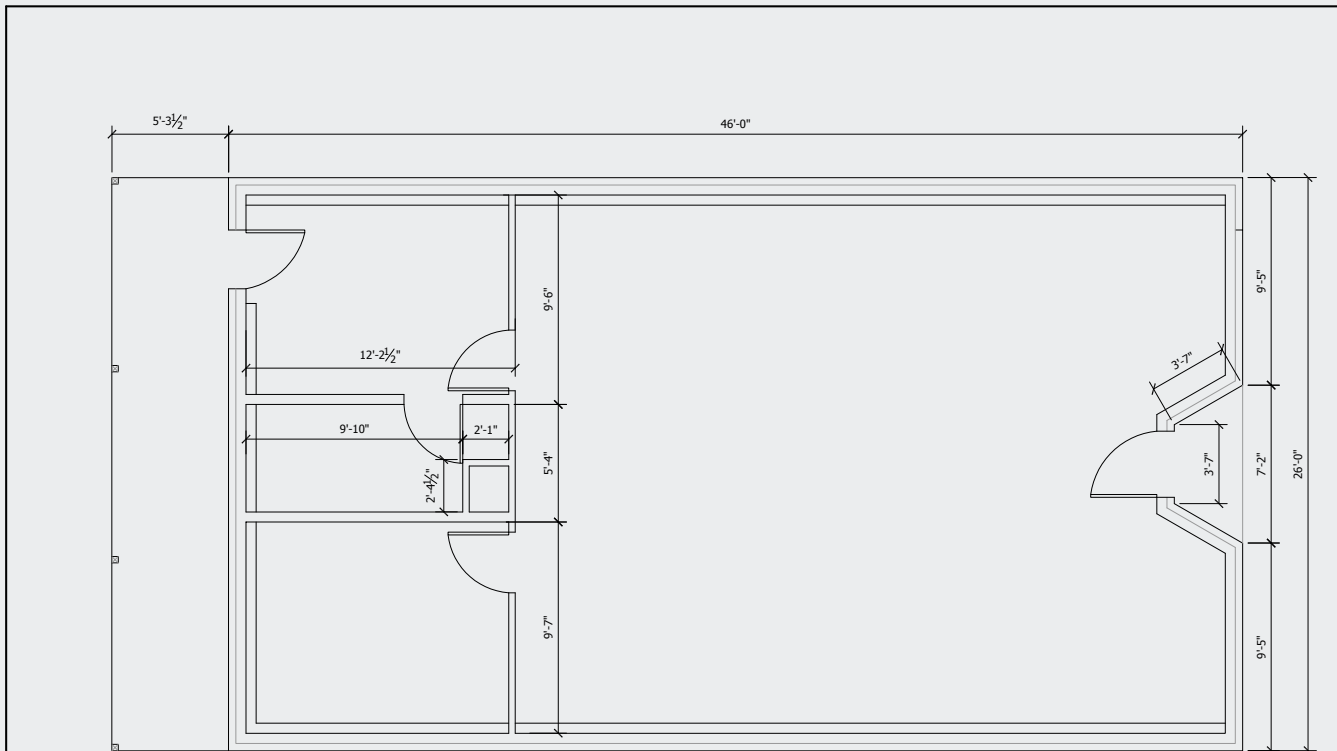

**16 FLOOR PLAN**  
A2.1 : A2.1

1/4" = 1'-0"

DRAWING: FLOOR PLAN	
PROJECT: 601 WEST 3RD ST.	
OWNER: CRAIG AND MEGAN KOSENA	
PROJECT #	00000100
DATE	02.01.10
REVISIONS	
<b>A&amp;E</b> ARCHITECTS	
ARCHITECTURE INTERIORS HISTORIC	
# 600 NORTH 237th BILLINGS, MT 59105 PH 406 248.2422 PH 406 248.2427 # 222 NORTH HIGGINS MISSOULA, MT 59802 PH 406 721.5643 PH 406 721.1887 www.aandmarch.com	
<b>A2.1</b>	