

PRIME LEASING OPPORTUNITY AVAILABLE



Bonavista Promenade Shopping Centre

755 Lake Bonavista Drive SE
Calgary, AB



CBRE

Demographics



55,472

Population Within 3 KM



\$160,375

Average Household
Income Within 3 KM



32% of population aged between
20 - 44 Years
Within 3 KM

Prime retail opportunity in a modern enclosed mall

- Modern suburban enclosed mall with ample parking.
- Anchored by Safeway with other tenants including Shoppers Drug Mart, TD, Circle K, Subway, Little Caesars and Brewsters.
- This neighborhood mall provides an excellent opportunity to foster and grow a business in an established and busy mall.
- Servicing the Communities of Lake Bonavista, Willow Park, Canyon Meadows, Queensland and Deer Run.

Space Available

Unit 131 - 962 sq. ft.

Unit 127 - 6,154 sq. ft.

Unit 169 - 937 sq. ft.

Unit 175 - 1,774 sq. ft.

BASIC RENT - Market

OP COSTS & TAXES - \$22.56 + Mgmt Fee (2026)

SIGNAGE - Fascia

POSSESSION - Unit 131 - Immediate

Unit 127 - April 1, 2026

Unit 169 - Immediate

Unit 175 - Immediate

ZONING - DC

TERM - 5 - 10 years



Leasing Plan

Main Floor



Unit 131 - Photos



Unit 127 - Photos and Floor Plan

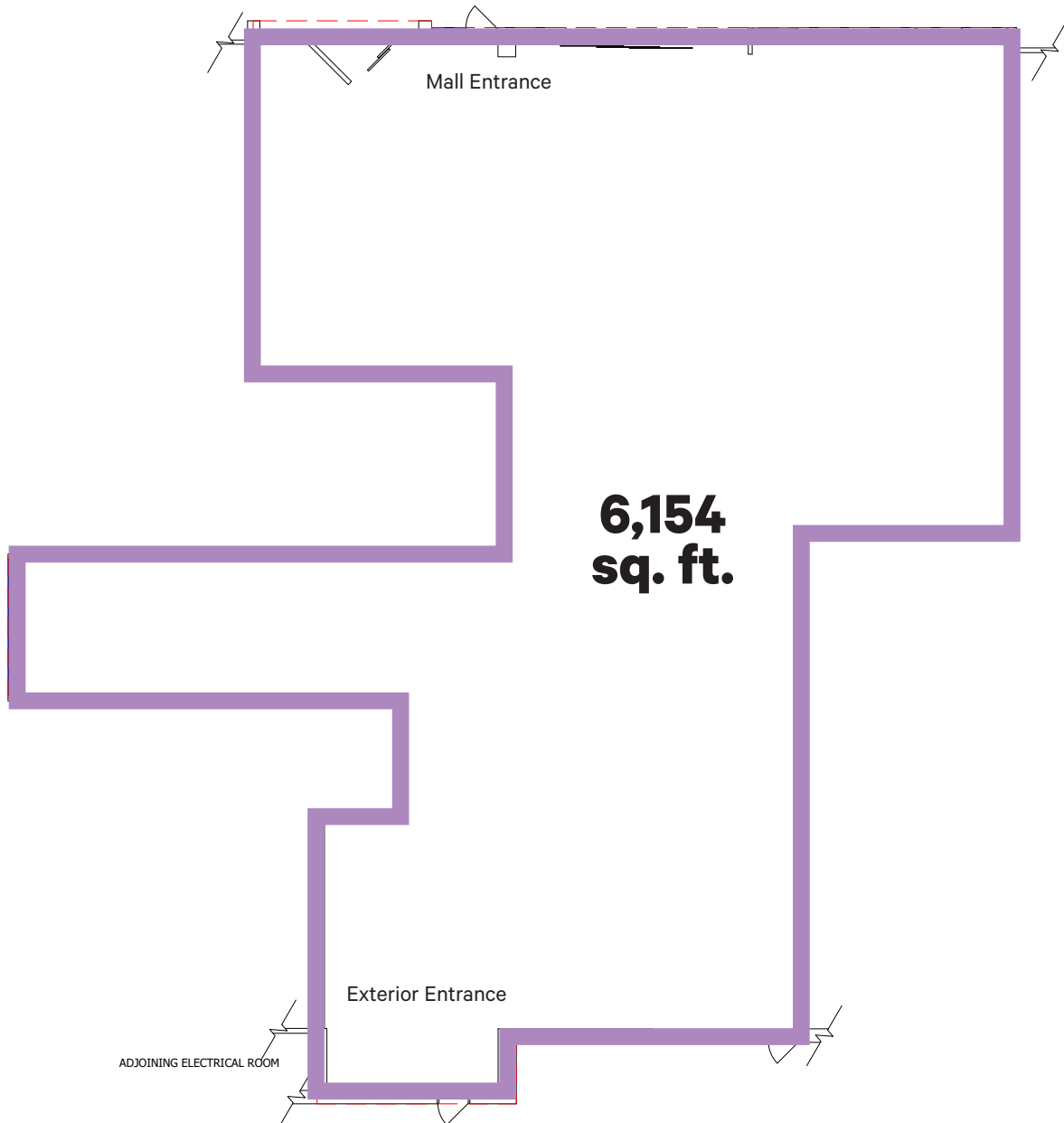

Unit 169 - Photo and Floor Plan



Unit 169 - Floor Plan

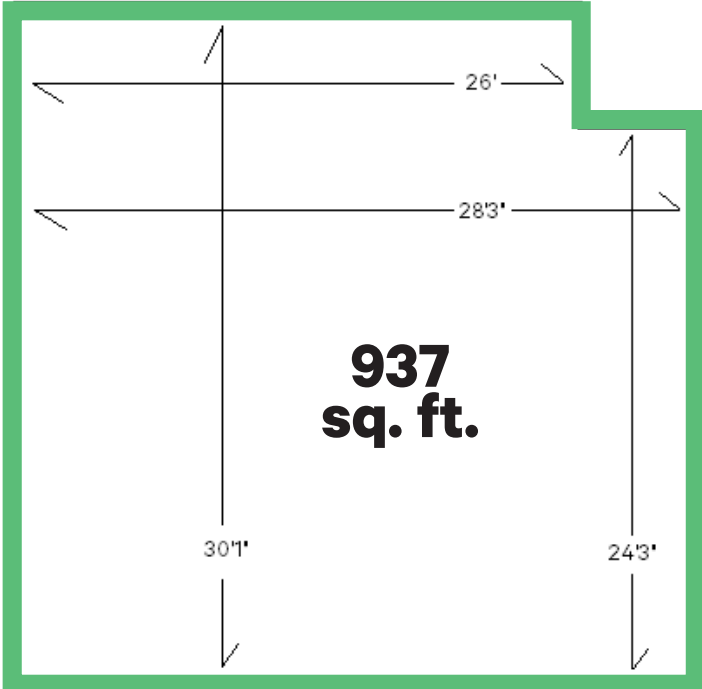

Unit 175 - Photos



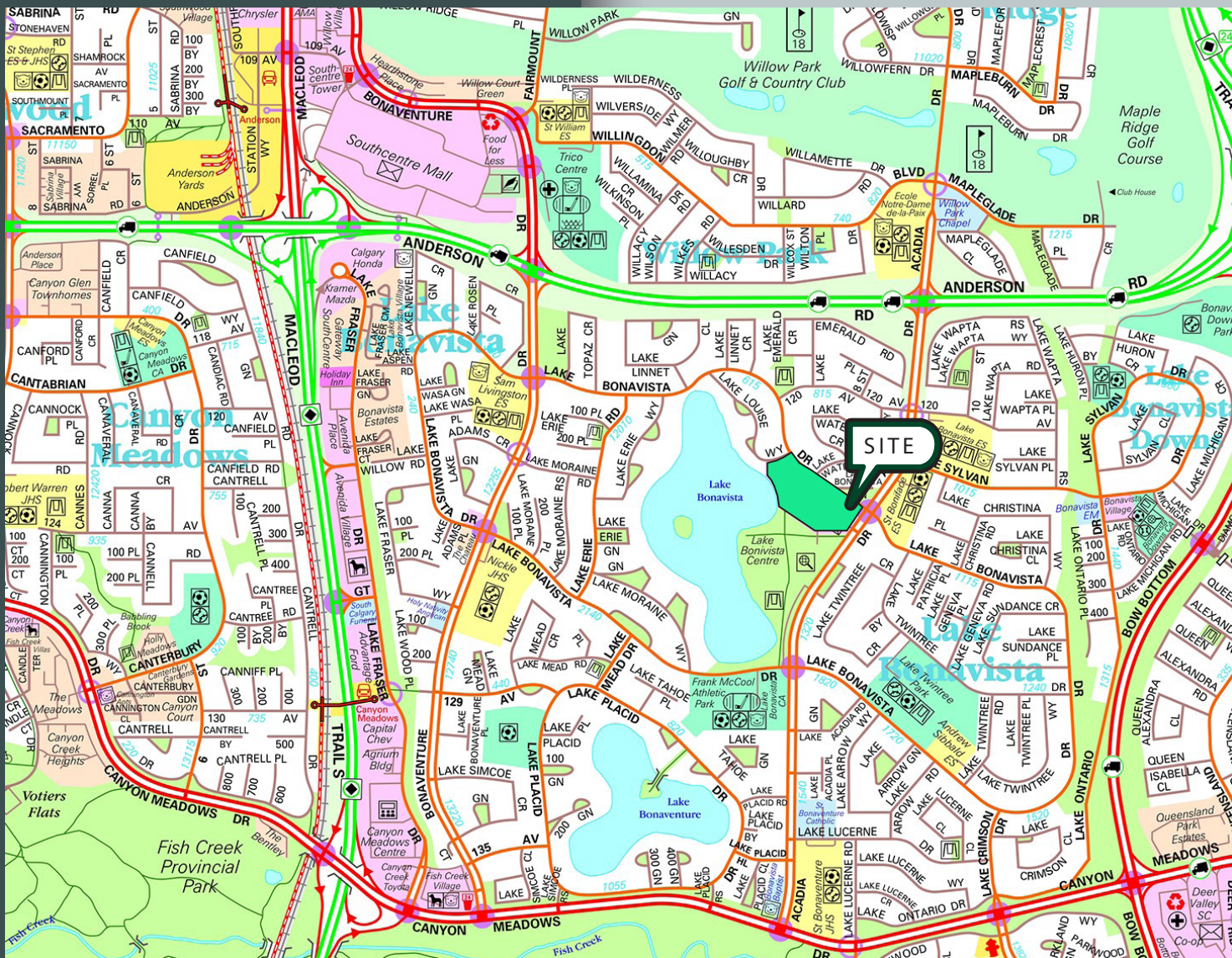

For More Information Please Contact

Alistair Corbett

Senior Vice President
403.294.5709
alistair.corbett@cbre.com

Cory Miles

Associate Vice President
403.750.0523
cory.miles@cbre.com

Mac Marcinew

Sales Associate
587.583.7197
mac.marcinew@cbre.com

Jayne Rogers

Transaction Manager
403.750.0535
jayce.rogers@cbre.com

Brandy Chorney

Marketing Specialist
403.303.3609
brandy.chorney@cbre.com

CBRE Calgary

Eighth Avenue Place

East Tower 525 8 Avenue SW Suite 3200

Calgary, Alberta T2P 1G1

This disclaimer shall apply to CBRE Limited, and to all divisions of the Corporation ("CBRE"). The information set out herein (the "Information") has not been verified by CBRE, and CBRE does not represent, warrant or guarantee the accuracy, correctness and completeness of the Information. CBRE does not accept or assume any responsibility or liability, direct or consequential, for the Information or the recipient's reliance upon the Information. The recipient of the Information should take such steps as the recipient may deem necessary to verify the Information prior to placing any reliance upon the Information. The Information may change and any property described in the Information may be withdrawn from the market at any time without notice or obligation to the recipient from CBRE. Mapping Sources: Canadian Mapping Services canadamapping@cbre.com; DMTISpatial, Environics Analytics, Microsoft Bing, Google Earth. Map© 2024 Sherlock Publishing Ltd.

