

LIVING AREA: 5281.94 sq ft • FLOORS: 1

▼ Ground Floor

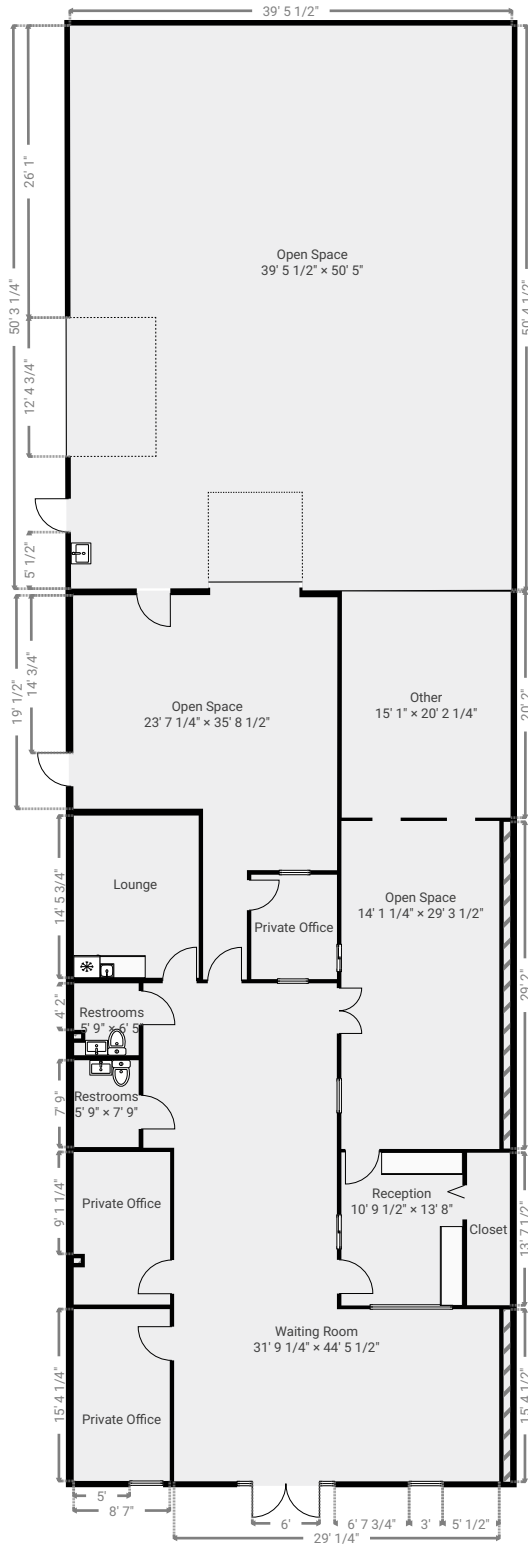

This floor plan is provided without warranty of any kind. Broken Crayon Photography, disclaims any warranty including, without limitation, satisfactory quality or accuracy of dimensions. While we do our best at being accurate, we cannot guarantee square footage calculations. While we are providing measurements and a floor plan ultimately, the real estate agent is responsible to make sure it's accurate. If you see a discrepancy, let us know immediately!

TOTAL AREA: 5255.73 sq ft • LIVING AREA: 5281.94 sq ft • FLOORS: 1

▼ **Lounge**  
Ground Floor

WIDTH: 11' 1 3/4" • LENGTH: 14' 5 3/4"  
AREA: 161.38 sq ft • PERIMETER: 51' 3"

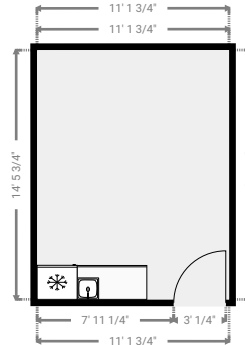
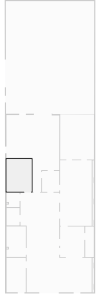

▼ **Open Space**  
Ground Floor

WIDTH: 14' 1 1/4" • LENGTH: 29' 3 1/2"  
AREA: 412.88 sq ft • PERIMETER: 86' 9 1/4"

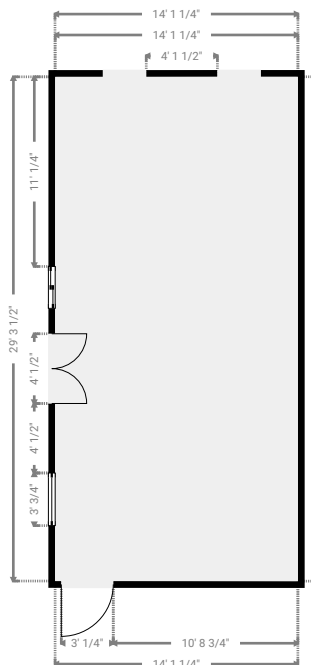
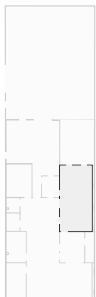

This floor plan is provided without warranty of any kind. Broken Crayon Photography, disclaims any warranty including, without limitation, satisfactory quality or accuracy of dimensions. While we do our best at being accurate, we cannot guarantee square footage calculations. While we are providing measurements and a floor plan ultimately, the real estate agent is responsible to make sure it's accurate. If you see a discrepancy, let us know immediately!

TOTAL AREA: 5255.73 sq ft • LIVING AREA: 5281.94 sq ft • FLOORS: 1

▼ **Open Space**  
Ground Floor

WIDTH: 23' 7 1/4" • LENGTH: 35' 8 1/2"  
AREA: 563.55 sq ft • PERIMETER: 118' 6"

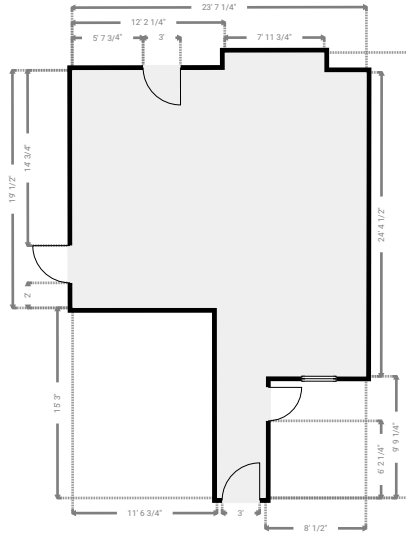
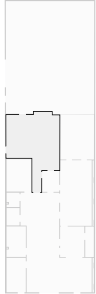

▼ **Open Space**  
Ground Floor

WIDTH: 39' 5 1/2" • LENGTH: 50' 5"  
AREA: 1974.04 sq ft • PERIMETER: 181' 6 1/4"

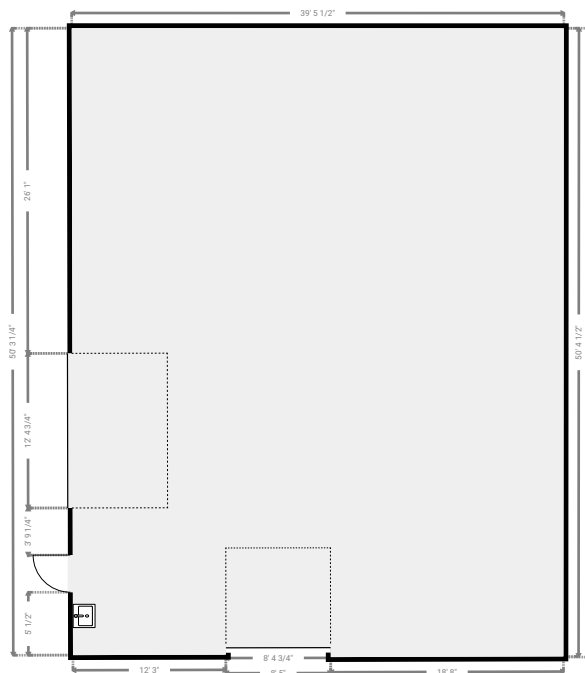

This floor plan is provided without warranty of any kind. Broken Crayon Photography, disclaims any warranty including, without limitation, satisfactory quality or accuracy of dimensions. While we do our best at being accurate, we cannot guarantee square footage calculations. While we are providing measurements and a floor plan ultimately, the real estate agent is responsible to make sure it's accurate. If you see a discrepancy, let us know immediately!

TOTAL AREA: 5255.73 sq ft • LIVING AREA: 5281.94 sq ft • FLOORS: 1

▼ Other  
Ground Floor

WIDTH: 15' 1" • LENGTH: 20' 2 1/4"  
AREA: 304.14 sq ft • PERIMETER: 70' 6"

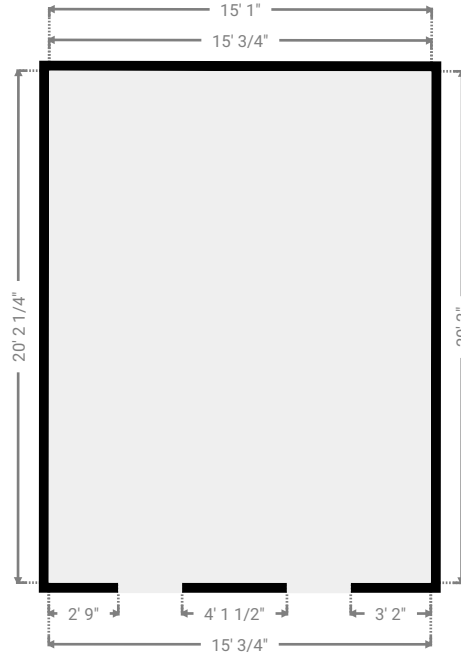

▼ Private Office  
Ground Floor

WIDTH: 8' 7" • LENGTH: 15' 4 1/4"  
AREA: 131.59 sq ft • PERIMETER: 47' 10"

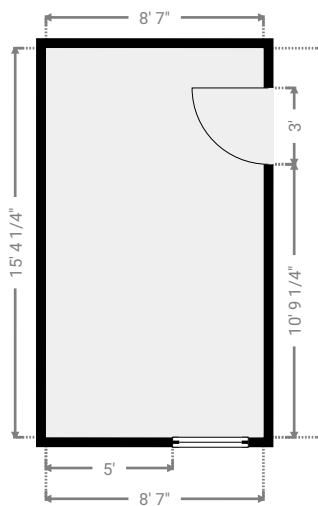

This floor plan is provided without warranty of any kind. Broken Crayon Photography, disclaims any warranty including, without limitation, satisfactory quality or accuracy of dimensions. While we do our best at being accurate, we cannot guarantee square footage calculations. While we are providing measurements and a floor plan ultimately, the real estate agent is responsible to make sure it's accurate. If you see a discrepancy, let us know immediately!

TOTAL AREA: 5255.73 sq ft • LIVING AREA: 5281.94 sq ft • FLOORS: 1

▼ **Private Office**  
Ground Floor

WIDTH: 8' 7 1/4" • LENGTH: 13' 7 1/2"  
AREA: 116.04 sq ft • PERIMETER: 46' 5 1/4"

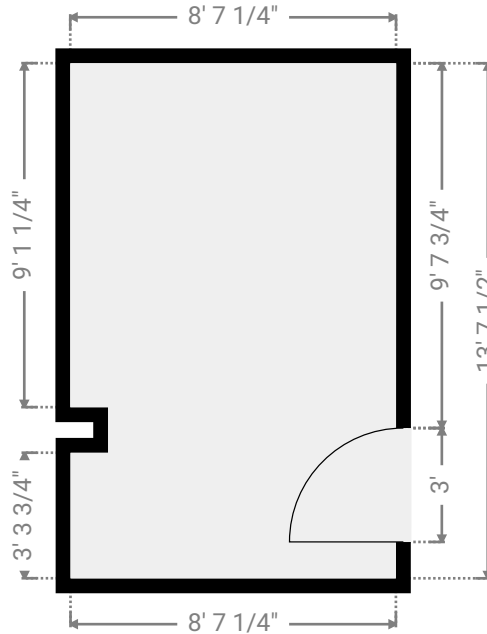

▼ **Private Office**  
Ground Floor

WIDTH: 7' 7 3/4" • LENGTH: 9' 3 3/4"  
AREA: 71.26 sq ft • PERIMETER: 33' 11 1/4"

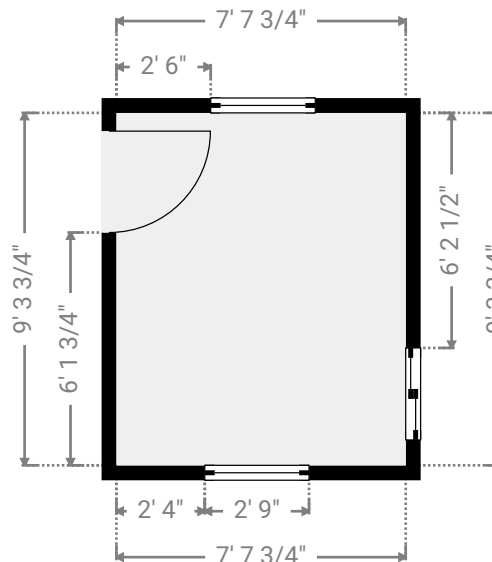

This floor plan is provided without warranty of any kind. Broken Crayon Photography, disclaims any warranty including, without limitation, satisfactory quality or accuracy of dimensions. While we do our best at being accurate, we cannot guarantee square footage calculations. While we are providing measurements and a floor plan ultimately, the real estate agent is responsible to make sure it's accurate. If you see a discrepancy, let us know immediately!

TOTAL AREA: 5255.73 sq ft • LIVING AREA: 5281.94 sq ft • FLOORS: 1

▼ **Reception**  
Ground Floor

WIDTH: 10' 9 1/2" • LENGTH: 13' 8"  
AREA: 147.54 sq ft • PERIMETER: 48' 11"

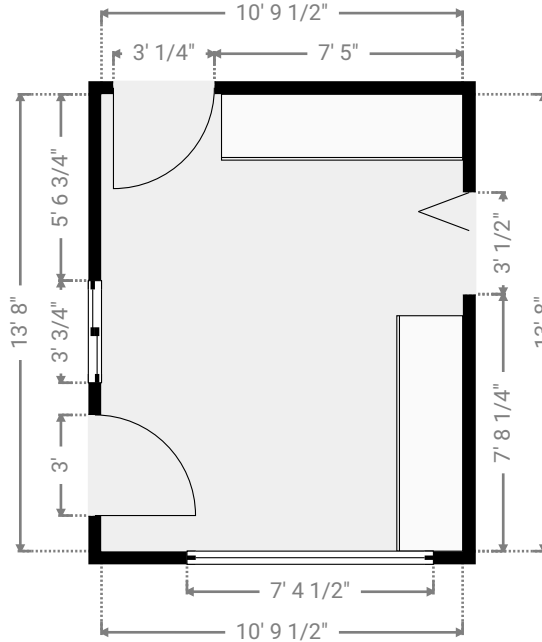

▼ **Closet**  
Ground Floor

WIDTH: 3' 9 3/4" • LENGTH: 13' 7 1/2"  
AREA: 51.97 sq ft • PERIMETER: 34' 10 1/2"

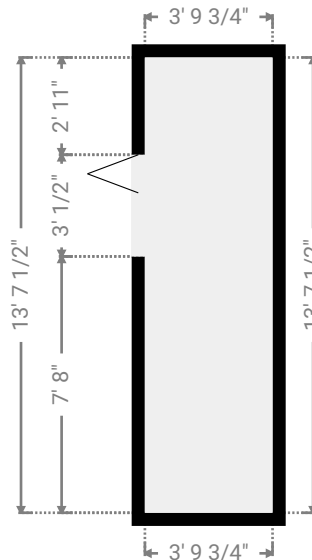

This floor plan is provided without warranty of any kind. Broken Crayon Photography, disclaims any warranty including, without limitation, satisfactory quality or accuracy of dimensions. While we do our best at being accurate, we cannot guarantee square footage calculations. While we are providing measurements and a floor plan ultimately, the real estate agent is responsible to make sure it's accurate. If you see a discrepancy, let us know immediately!

TOTAL AREA: 5255.73 sq ft • LIVING AREA: 5281.94 sq ft • FLOORS: 1

▼ Restrooms  
Ground Floor

WIDTH: 5' 9" • LENGTH: 7' 9"  
AREA: 44.60 sq ft • PERIMETER: 27' 1/4"

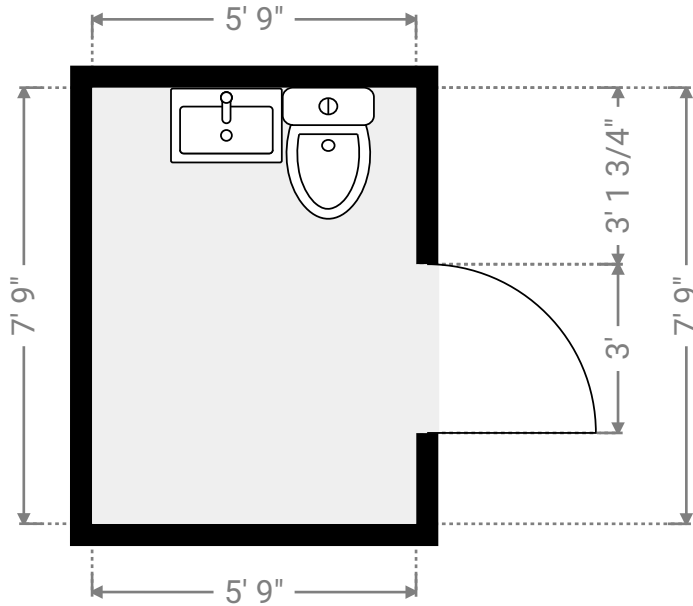

▼ Restrooms  
Ground Floor

WIDTH: 5' 9" • LENGTH: 6' 5"  
AREA: 35.80 sq ft • PERIMETER: 26' 4 1/4"

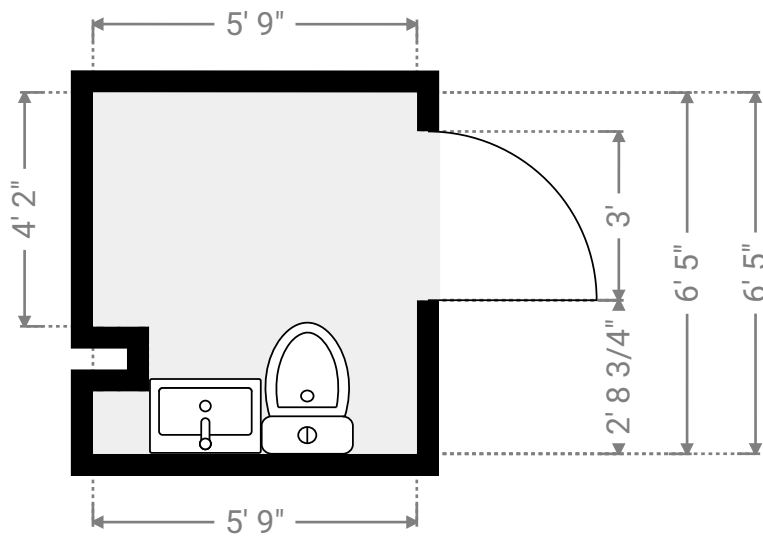

This floor plan is provided without warranty of any kind. Broken Crayon Photography, disclaims any warranty including, without limitation, satisfactory quality or accuracy of dimensions. While we do our best at being accurate, we cannot guarantee square footage calculations. While we are providing measurements and a floor plan ultimately, the real estate agent is responsible to make sure it's accurate. If you see a discrepancy, let us know immediately!

TOTAL AREA: 5255.73 sq ft • LIVING AREA: 5281.94 sq ft • FLOORS: 1

▼ **Waiting Room**  
Ground Floor

WIDTH: 31' 9 1/4" • LENGTH: 44' 5 1/2"  
AREA: 909.17 sq ft • PERIMETER: 152' 5 3/4"

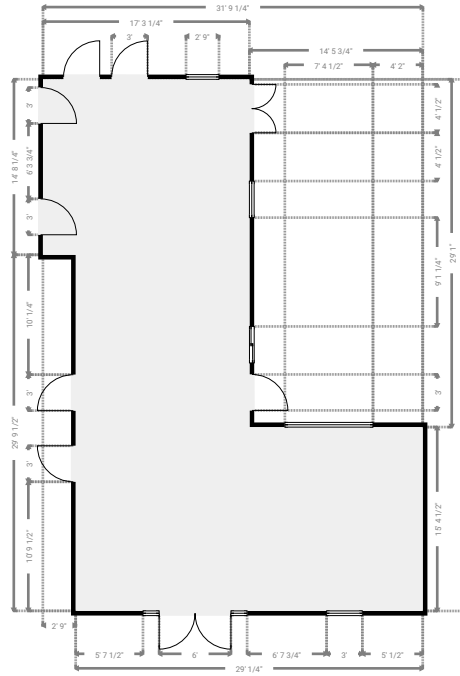

This floor plan is provided without warranty of any kind. Broken Crayon Photography, disclaims any warranty including, without limitation, satisfactory quality or accuracy of dimensions. While we do our best at being accurate, we cannot guarantee square footage calculations. While we are providing measurements and a floor plan ultimately, the real estate agent is responsible to make sure it's accurate. If you see a discrepancy, let us know immediately!