

# For lease

5760 9 Street SE  
Calgary, AB



## Second floor office unit in south inner city

- Quick access to Blackfoot Trail, Glenmore Trail, and Deerfoot Trail via 58 Avenue SE
- Close proximity to amenities in the Deerfoot Meadows retail area
- Exterior signage opportunity on signage monument
- Main floor lounge available



## Main Floor Lounge

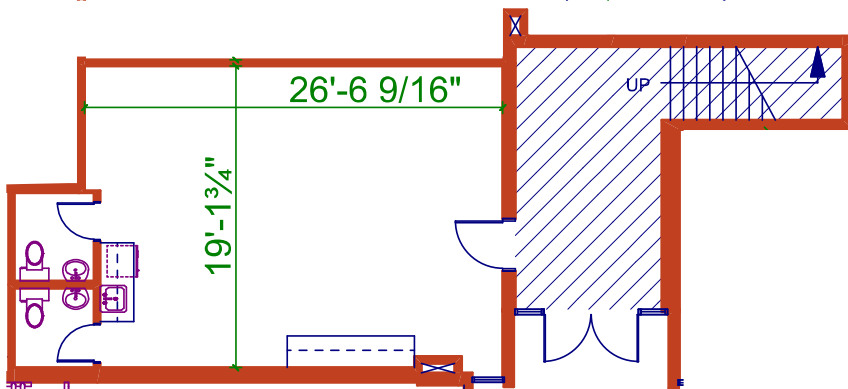

# Suite 109

## 8,303 sf

- Reception area
- In-Suite washrooms with showers
- Lounge area at entrance of the building
- 2 offices
- Large workstation area
- Kitchen

## Suite Details

<b>Availability</b>	Immediate
<b>Rental Rate</b>	Market Rates
<b>Term</b>	Flexible
<b>Operating Costs and Taxes</b>	\$5.69 p.s.f (Est 2026)
<b>Parking Information</b>	Surface parking stalls available at no cost
<b>Suite Notes</b>	Furniture is negotiable

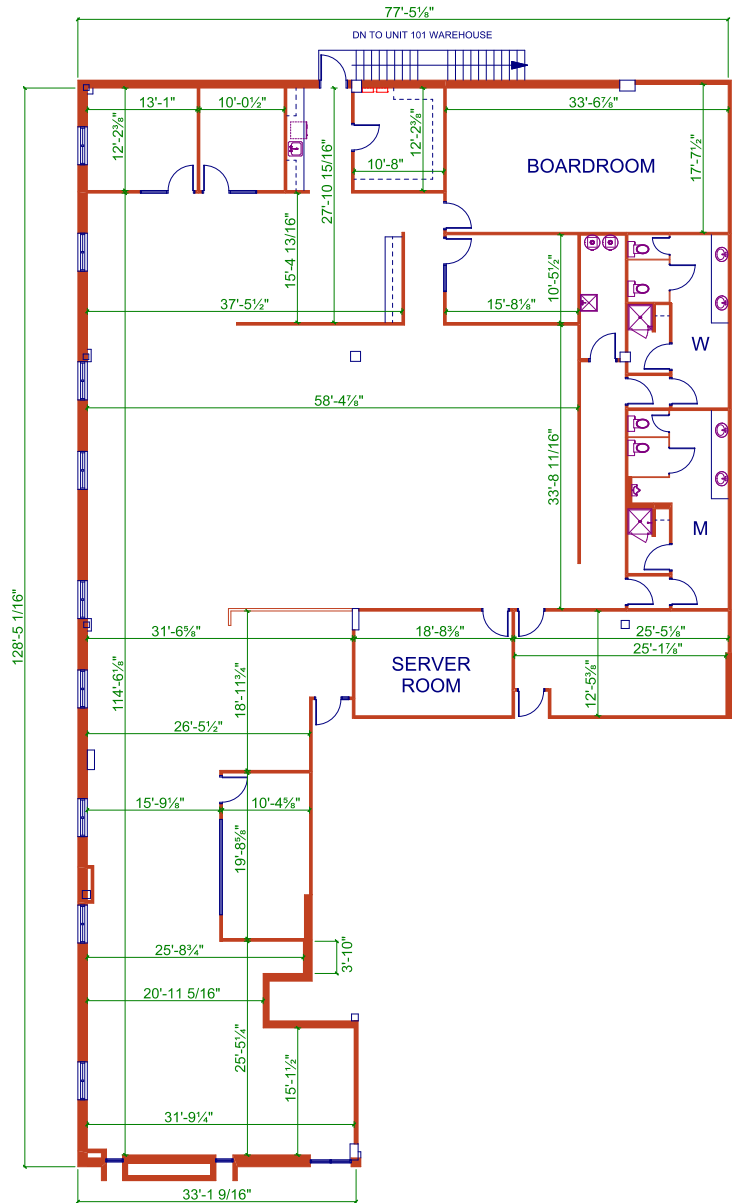



**For more information please contact**

**Kara Dusseldorp**  
Associate Vice President  
403 456 2348  
kara.dusseldorp@jll.com

**James McKenzie**  
Vice President  
403 456 8100  
james.mckenzie@jll.com