



# COMMERCIAL OFFICE CONDO FOR SALE

484 Mobil Avenue Camarillo CA 93010



## **BUENGER**

**COMMERCIAL REAL ESTATE, INC.**

**Prime Location: Corner of Pickwick Drive & Mobil Avenue**

*Owner / User or Investment*

3600 South Harbor Blvd. Oxnard CA, 93035. Phone: (805) 985-1007 Fax: (805) 725-3122  
Info@BuengerInc.com www.BuengerInc.com  
CalDRE License: 1378022

## BUILDING OVERVIEW

- Center: Buena Venture Plaza
- Address: 484 Mobil Avenue Camarillo CA 93010
- Type: Office Condos
- Jurisdiction: City of Camarillo
- Building Square footage: 25,680
- Number of Buildings: 3
- Year Built: 1979
- Zoning: Commercial Planned Development
- Parking: Common



## AVAILABLE CONDO FOR SALE

Address	Suite	SQ Feet	APN	Price	Per Foot	Lease	Current
484 MOBIL AVE	7	500	165-0-440-075	\$187,500	\$375	Month to Month	Office



# BUENGER

COMMERCIAL REAL ESTATE, INC.

3600 South Harbor Blvd. Oxnard CA, 93035. Phone: (805) 985-1007 Fax: (805) 725-3122  
Info@BuengerInc.com www.BuengerInc.com  
CalDRE License: 1378022

## **OFFICE CONDO**

Current Build out: Office

500 Square Feet

Lease: Month to Month

**For Sale at \$187,500**

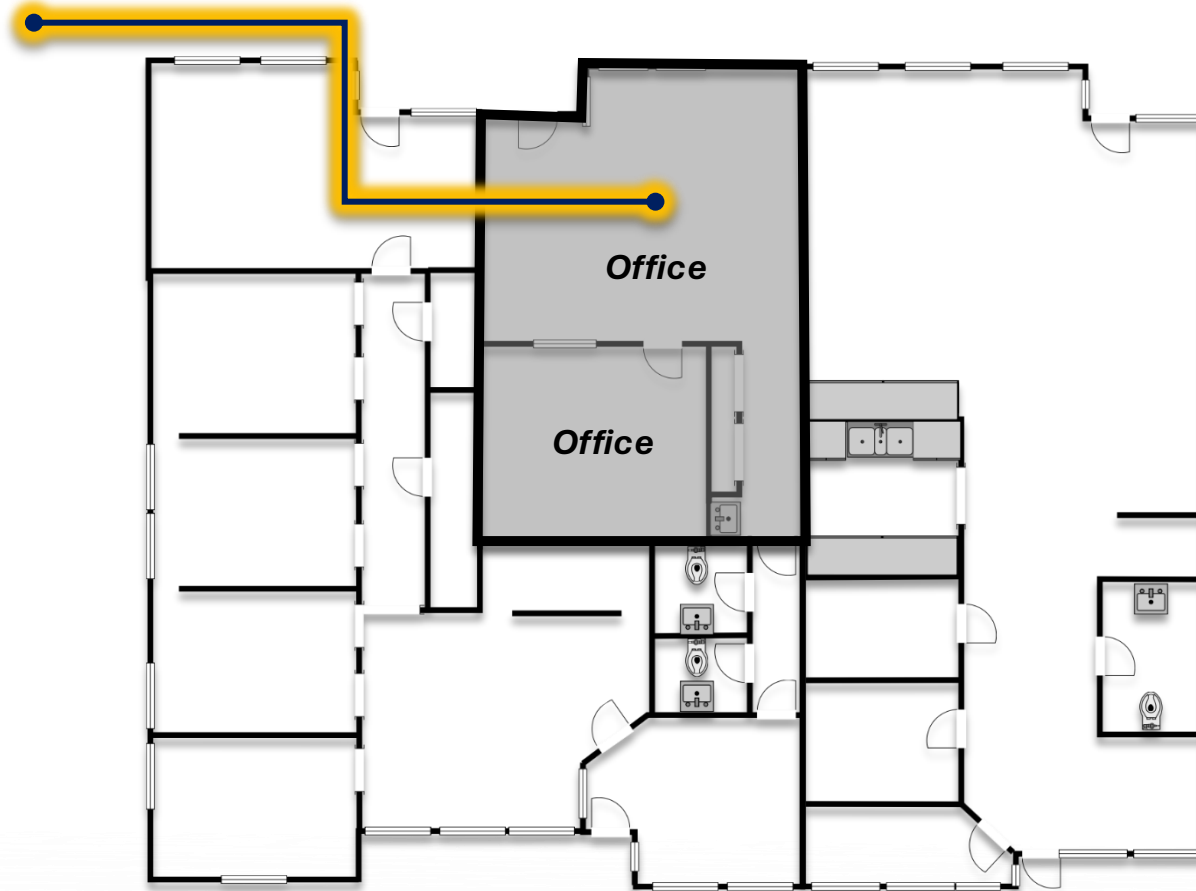

# **BUENGER**

**COMMERCIAL REAL ESTATE, INC.**

3600 South Harbor Blvd. Oxnard CA, 93035. Phone: (805) 985-1007 Fax: (805) 725-3122

Info@BuengerInc.com www.BuengerInc.com

CalDRE License: 1378022

## OFFICE CONDO

Suite: 7

Current Build out: Office

500 Square Feet

Lease: Month to Month

Restroom: Common

For Sale at \$187,500



Address	Suite	SQ Feet	APN	Price	Per Foot	Current	Property Taxes	HOA Fees Yearly	Monthly Rent	Yearly Rents
484 MOBIL AVE	7	500	165-0-440-075	\$187,500	\$375	Visiting Angels	\$2,149.36	\$2,160.00	\$1,238.00	\$14,856.00



# BUENGER

COMMERCIAL REAL ESTATE, INC.

3600 South Harbor Blvd. Oxnard CA, 93035. Phone: (805) 985-1007 Fax: (805) 725-3122  
Info@BuengerInc.com www.BuengerInc.com  
CalDRE License: 1378022

**OFFICE CONDO**

Current Build out: Office

500 Square Feet

Lease: Month to Month

For Sale at \$187,500

PICKWICK DRIVE

MOBIL AVENUE



**BUENGER**

COMMERCIAL REAL ESTATE, INC.

3600 South Harbor Blvd. Oxnard CA, 93035. Phone: (805) 985-1007 Fax: (805) 725-3122

Info@BuengerInc.com www.BuengerInc.com

CalDRE License: 1378022

PORTION SECTION 28, 1.2N., R.21W.

**OFFICE CONDO**  
 Current Build out: Office  
 500 Square Feet



PICKWICK DRIVE

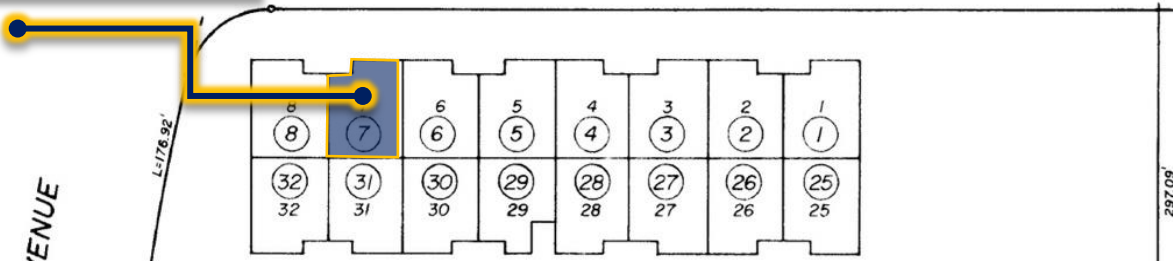

AVENUE

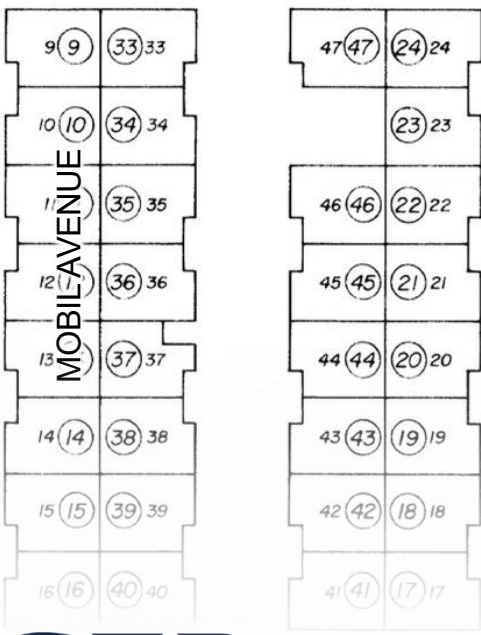

LOT 48 COMMON AREA

07

14



**BUENGER**  
 COMMERCIAL REAL ESTATE, INC.

3600 South Harbor Blvd. Oxnard CA, 93035. Phone: (805) 985-1007 Fax: (805) 725-3122  
 Info@BuengerInc.com www.BuengerInc.com  
 CalDRE License: 1378022

# City of Camarillo

PONDEROSA DRIVE

Lombardo's  
GOURMET DELI & MEATS

El Encanto  
RESTAURANT

Do it Best

Country Harvest  
FRESH LOCAL GROWNS

little Caesars

The Medicine Shoppe  
PHARMACY

NAPA

UNITED STATES  
POSTAL SERVICE

Auto Zone

OUTLAWS  
Grill & Saloon  
CAMARILLO, CA

DOLLAR TREE

MOBIL AVENUE



BANK OF AMERICA

ARCO CHASE



VENTURA COUNTY  
CREDIT UNION

usbank

CITIZENS  
BUSINESS BANK  
A Financial Services Company

484 Mobile Ave

harley's

TOPPERS  
PIZZA PLACE

Smart & Final FedEx

TUTORIFICI

goodwill

Wendy's

Chevron

HECTOR'S

DUNKIN'  
DONUTS

FITNESS 19

presto pasta

Budget

WaBa grill

Habit  
BURGER & GRILL

Rosa Madera

BAJA FRESH

PICKWICK DRIVE

ARNIEL ROAD

BURGER KING

EAST DAILY DRIVE

101 FREEWAY



# BUENGER

COMMERCIAL REAL ESTATE, INC.

3600 South Harbor Blvd. Oxnard CA, 93035. Phone: (805) 985-1007 Fax: (805) 725-3122  
Info@BuengerInc.com www.BuengerInc.com  
CalDRE License: 1378022

## Camarillo



# City of Camarillo

Camarillo is a city in Ventura County known for its rich agricultural roots, mild coastal climate, and strong sense of community. Throughout the year, Camarillo hosts community events that celebrate its culture and close-knit atmosphere. The Camarillo Fiesta and Street Fair, held annually, features live entertainment, local vendors, and family-friendly activities that draw residents and visitors alike. The city is also known for the Camarillo Premium Outlets, a major shopping destination that hosts special sales events throughout the year, contributing to the local economy and tourism. Together, Camarillo's rich history and vibrant events reflect a community that honors its past while continuing to grow and modernize.



# BUENGER

COMMERCIAL REAL ESTATE, INC.

3600 South Harbor Blvd. Oxnard CA, 93035. Phone: (805) 985-1007 Fax: (805) 725-3122  
Info@BuengerInc.com www.BuengerInc.com  
CalDRE License: 1378022



# BUENGER

COMMERCIAL REAL ESTATE, INC.

*Broker Disclaimers -- This offering memorandum is confidential and has been prepared by Buenger Commercial Real Estate, Inc. (Broker) solely for the use of prospective purchasers. This offering memorandum is not intended to provide all the information necessary to reach a purchase decision. Each prospective Buyer is strongly encouraged to conduct their own thorough review and due diligence. Financial Information -- While the financial, operations, property description, projections, and other information herein is deemed to be reliable, neither the Broker nor Owner guarantee, represent, or warrant its accuracy. Pro forma projections are prepared by Broker based on many assumptions and events over which the Broker and the Owner have no control and are not guaranteed. Buyers should use projections for review and are strongly urged to conduct their own study on projections. No liability is assumed for errors, omissions, misstatements of fact, prior sale, change-of-price, or withdrawal from the market without notice. Environmental -- The Seller and Broker make no representations whatsoever about any environmental conditions on the property, including but not limited to issues such as asbestos, hazardous waste, mold, mildew, petroleum leaks, or spills. Each prospective Buyer is encouraged to do their own study and analysis to determine the status of various issues. Agency -- Buenger Commercial Real Estate, Inc. is the exclusive agents of the Seller, represent the Seller only, and shall be compensated by Seller. Confidentiality -- All information contained in this offering is confidential in nature and must be held in the strictest confidence, except information which is a matter of public record. Please do not visit the property without making prior arrangements through the Broker. Please do not contact tenant or property owner, nor talk to any employees. All due diligence information and all property tours must be provided by Buenger Commercial Real Estate, Inc.*