

# I-94 DISTRIBUTION CENTER

22000 Industrial Blvd  
Rogers, MN 55374



**STACK**  
INDUSTRIAL PARTNERS

# PROPERTY OVERVIEW

## General Building Information

**Year Built**  
Built 1993 | Expansion in 1998

**Construction Type**  
Concrete Tilt-Up

**Zoning**  
GI (General Industrial)

**Building Ownership**  
Dalfen Industrial

## Building Specifications

**Total Square Footage**  
297,256 SF

**Parcel Size**  
16.17 acres

**Clear Height**  
24'

**Bay Size**  
+/- 11,000 SF

**Bay Depth**  
265'

**Column Spacing**  
42' 6" x 38' 6"

**Truck Court**  
120'

**Parking Ratio**  
77 stalls | 0.26 per 1,000 SF

**Roof Type | Age**  
Rubber Membrane | 2015

**Sprinkler System**  
ESFR

## Utilities

**Cable & Internet Provider**  
Comcast

**Power Provider**  
Xcel Energy

**Gas Provider**  
CenterPoint Energy

**Water/Sewer**  
City of Rogers

## Financials

**Lease Rate**  
Negotiable

**2026 CAM & TAX**  
\$3.93/SF

# SITE PLAN

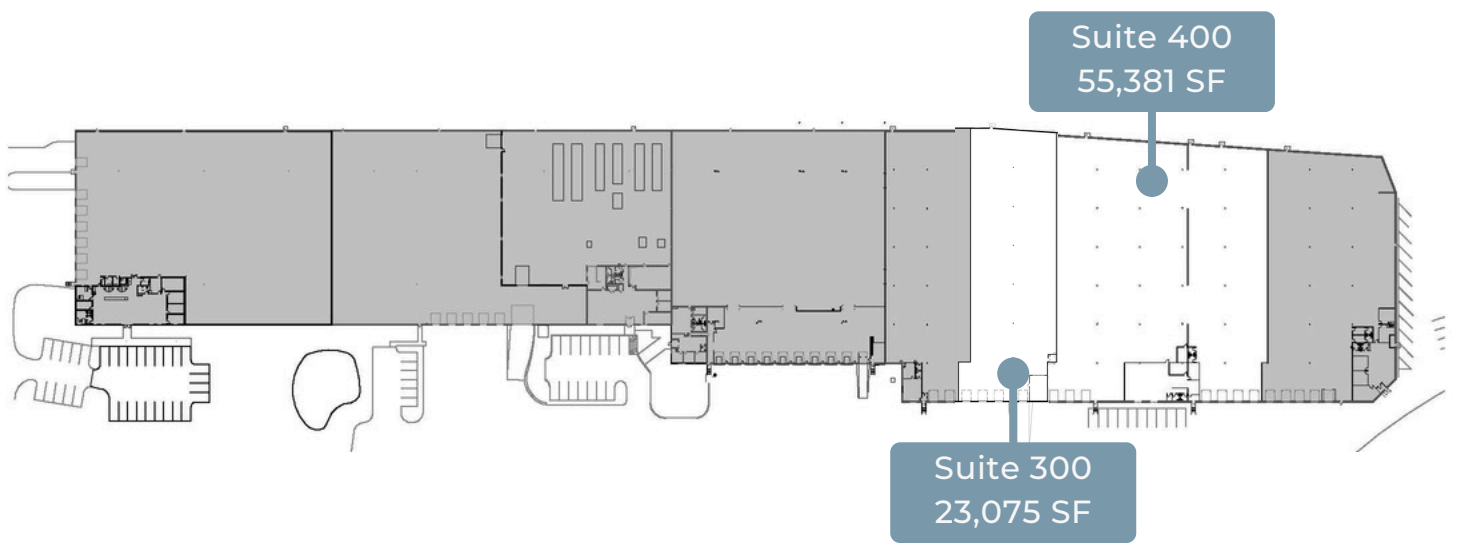

297,256 SF  
Total SF



0.26/1000 SF  
Parking Ratio



24'  
Clear Height

# AVAILABILITY SUMMARY

## Suite 300

### Date Available

60 day notice

### Total SF

23,075 SF

### Square Footage Breakdown

Office: 425 SF

Warehouse: 22,650 SF

### Power

200 amp main disconnect, 3-phase

150 amp, 120/208V panel

250 amp, 277/480V panel

### HVAC

Radiant Heater: Manuf: Roberts Gordon | Model: BH-200 | Serial: 9906-071-200-0137

Radiant Heater: Manuf: Roberts Gordon | Model: BH-200 | Serial: 9906-071-200-0134

Mini Split: Manuf: Mitsubishi | Model: MUZ-GL15NA | Serial: 5ZC00139 | Wall Mounted in Office,  
Condenser on Roof | 1 ¼ Ton (15,000 BTU)

### Loading Docks

Qty. 3 | 9' x 10'

### Drive in Doors

Qty. 1 | 9' x 10'

### Specialty Features

Freeway visibility and signage

Access to I-94 within half mile

Ability to add more power

# AVAILABILITY SUMMARY

## Suite 400

### Date Available

Today

### Total SF

55,381 SF

### Square Footage Breakdown

Office: 3,253 SF

Warehouse: 52,128 SF

### Power

200 amp main disconnect, 3-phase

150 amp, 120/208V panel

250 amp, 277/480V panel

### HVAC

Radiant Heater: Manuf: Roberts Gordon | Model: BH-200 | Serial: 9906-071-200-0136

Radiant Heater: Manuf: Roberts Gordon | Model: BH-200 | Serial: 9901-071-200-0010

RTU: Manuf: Lennox | Model: TGA09052BM1Y | Serial: 5605K12234 | Tonnage: 7.5 ton

### Loading Docks

Qty. 6 | 9' x 10'

### Drive in Doors

Qty. 1 | 9' x 10'

### Specialty Features

Freeway visibility and signage

Access to I-94 within half mile

Ability to add more loading and power

# AVAILABILITY SUMMARY

## Suites 300 & 400

### Date Available

With 60 day notice

### Total SF

78,456 SF

### Square Footage Breakdown

Office: 3,678 SF

Warehouse: 74,778 SF

### Power Suite 300

200 amp main disconnect, 3-phase

150 amp, 120/208V panel

250 amp, 277/480V panel

### Power Suite 400

200 amp main disconnect, 3-phase

150 amp, 120/208V panel

250 amp, 277/480V panel

### HVAC Suite 300

Radiant Heater: Manuf: Roberts Gordon | Model: BH-200 | Serial: 9906-071-200-0137

Radiant Heater: Manuf: Roberts Gordon | Model: BH-200 | Serial: 9906-071-200-0134

Mini Split: Manuf: Mitsubishi | Model: MUZ-GL15NA | Serial: 5ZC00139 | Wall Mounted in Office,  
Condenser on Roof | 1 ¼ Ton (15,000 BTU)

### HVAC Suite 400

Radiant Heater: Manuf: Roberts Gordon | Model: BH-200 | Serial: 9906-071-200-0136

Radiant Heater: Manuf: Roberts Gordon | Model: BH-200 | Serial: 9901-071-200-0010

RTU: Manuf: Lennox | Model: TGA09052BM1Y | Serial: 5605K12234 | Tonnage: 7.5 ton

### Loading Docks

Qty. 9 | 9' x 10'

### Drive in Doors

Qty. 2 | 9' x 10'

### Specialty Features

Freeway visibility and signage

Access to I-94 within half mile

Ability to add more loading and power

# AVAILABLE SPACE | SUITE 300

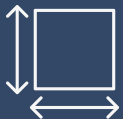
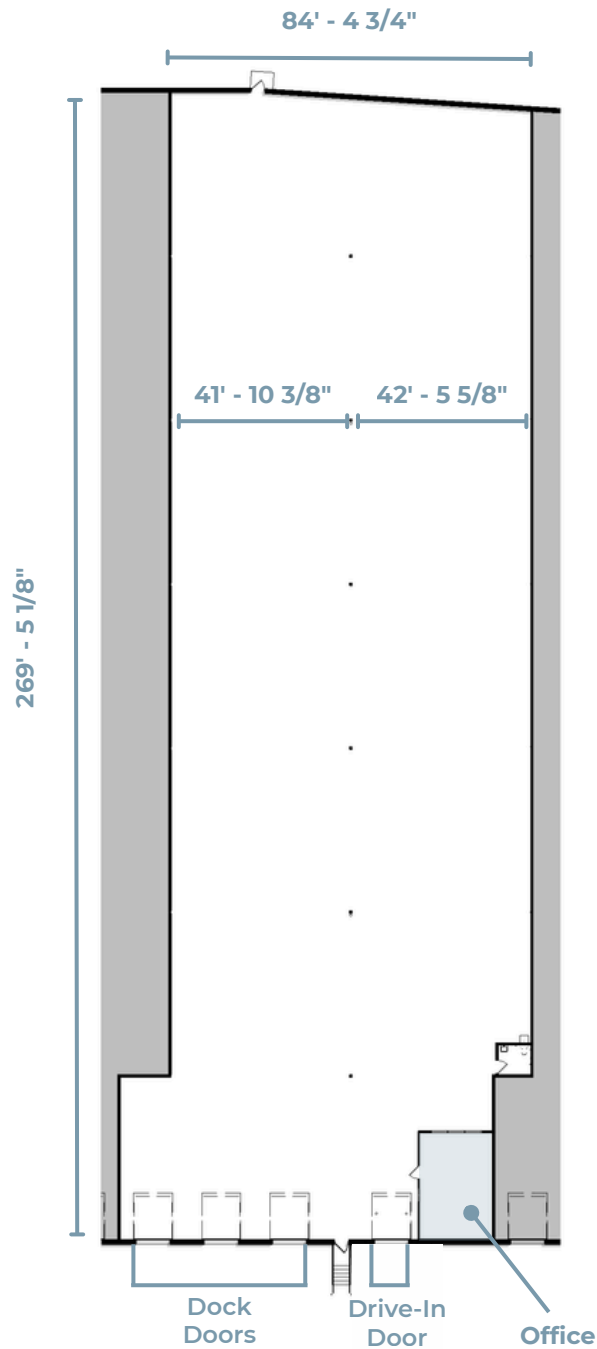

23,075 SF

Total



425 SF

Office



22,650 SF

Warehouse

# AVAILABLE SPACE | SUITE 400

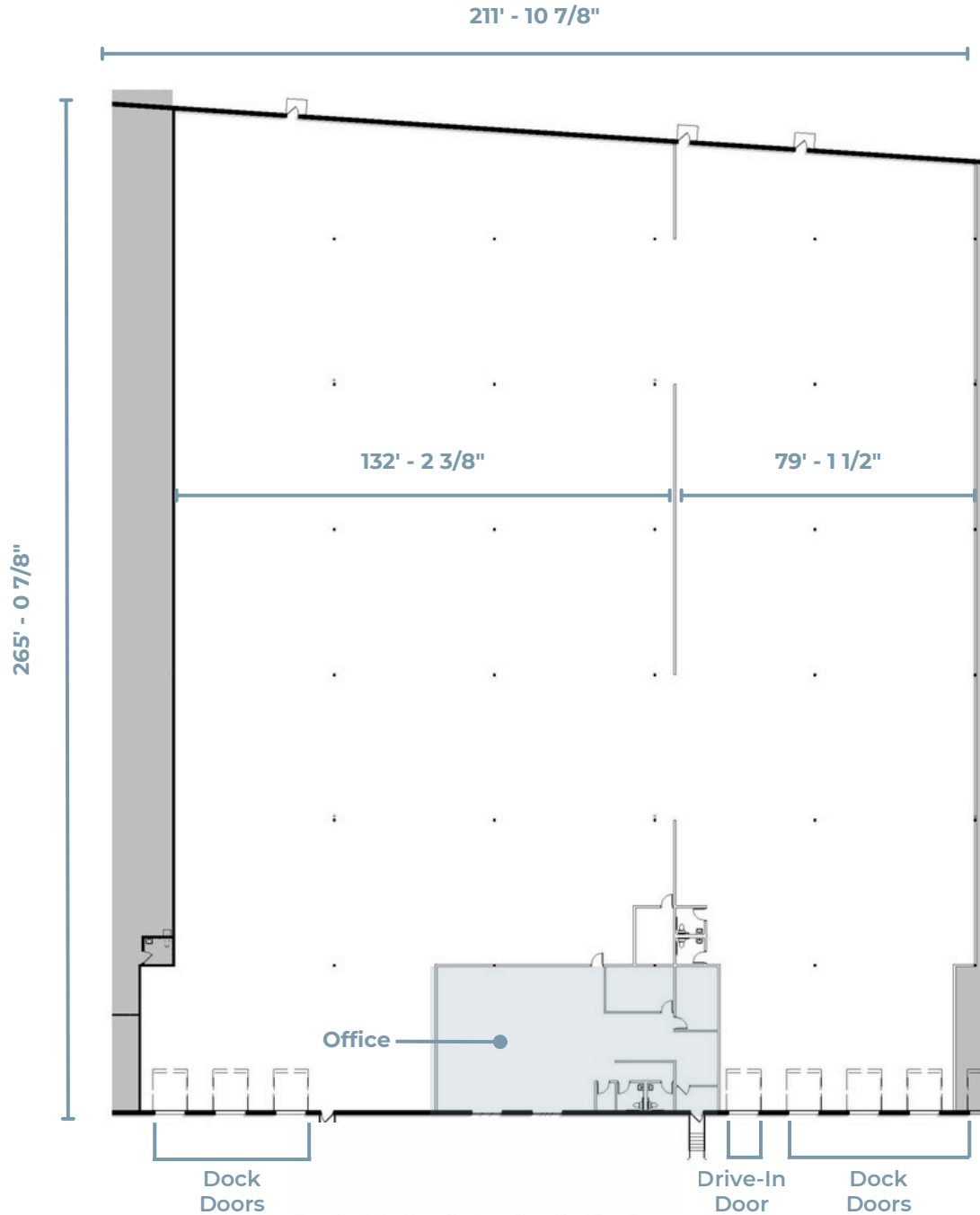

55,381 SF

Total



3,253 SF

Office



52,128 SF

Warehouse

# ALTERNATIVE PLAN | SUITE 400

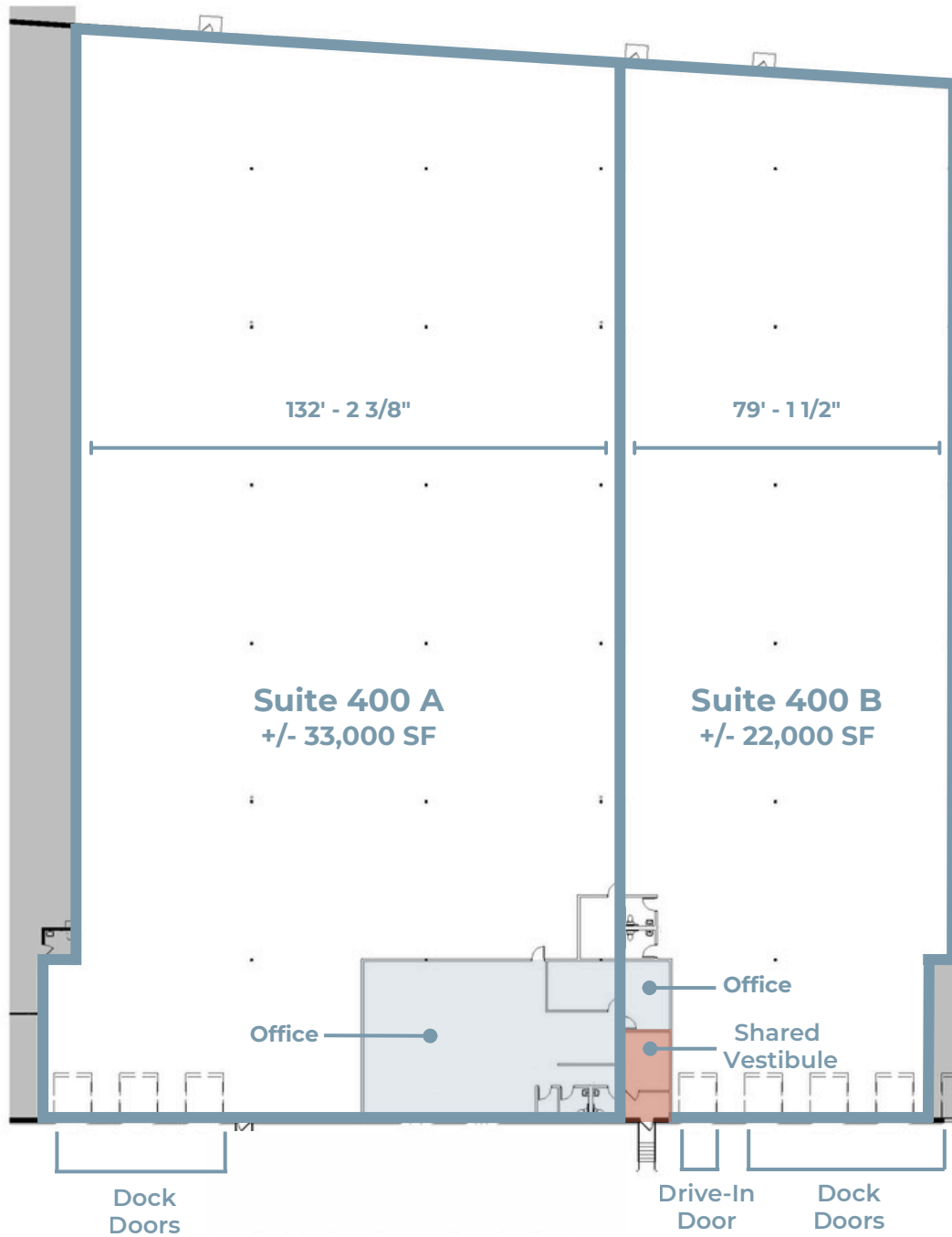

+/- 33,000 SF

Suite A



+/- 22,000 SF

Suite B

# LOCATION

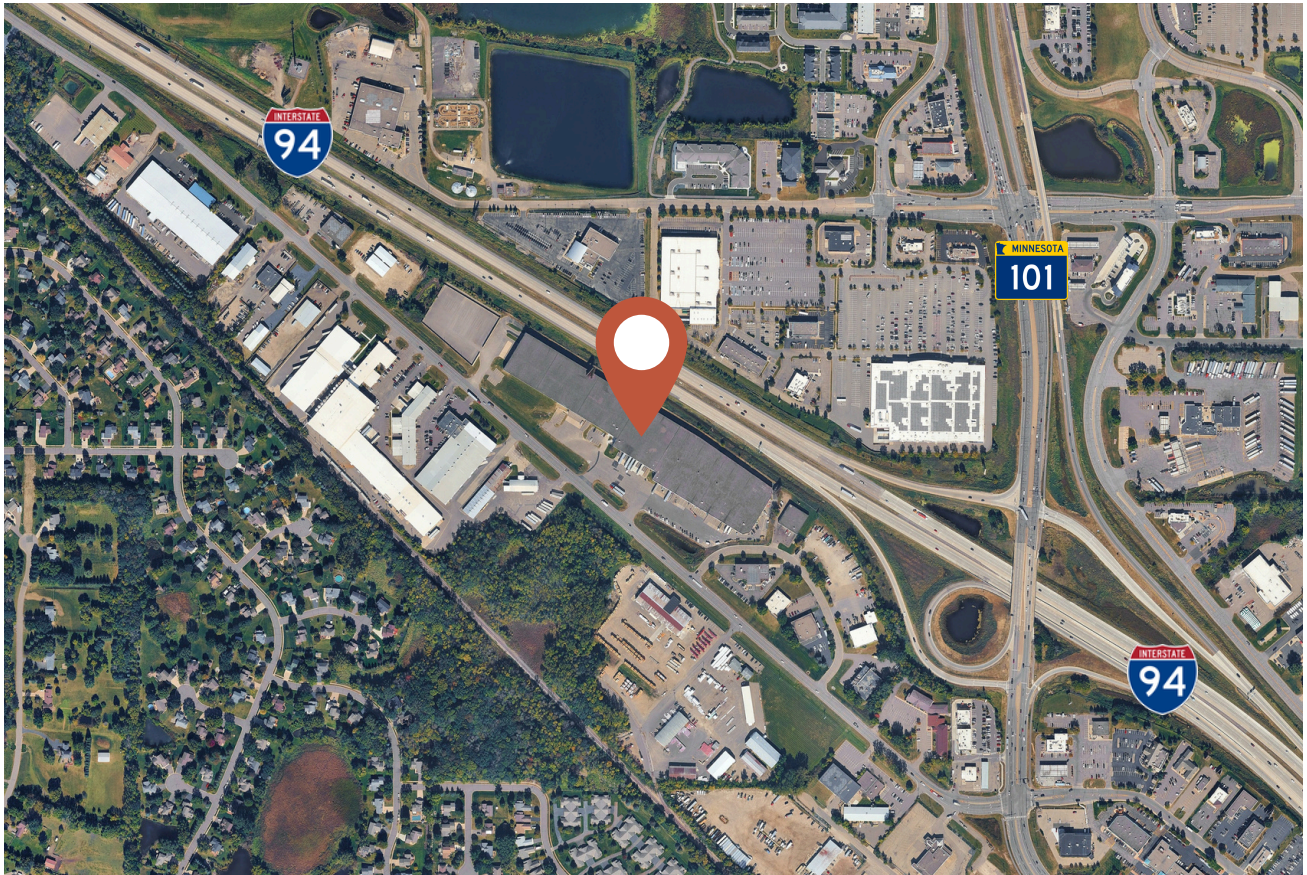

## Restaurants within 2 miles

Clive's Roadhouse  
Maynard's Restaurant of Rogers  
R Social On Main  
The Block Food + Drink  
Lindas' Cafe  
Short or Tall Eatery & Drink Hall  
Rolls and Bowls Asian Cook House  
Guadalajara Mexican Restaurant



## Retail Shops within 2 miles

Comprehensive Inventory Solutions  
MotoAlliance  
Treasures Galore on 94  
Antique Mall of Rogers  
Kohl's  
Custom Distribution  
Target  
Northern Tool + Equipment

# PHOTOS



**Nate Erickson, SIOR**

nate.erickson@stackindustrial.com

612-201-8943

**Alex Baron, SIOR**

alex.baron@stackindustrial.com

763-226-3476

[stackindustrial.com](http://stackindustrial.com) 

**STACK**  
INDUSTRIAL PARTNERS