

Oxford Companies  
734.665.6500  
oxfordcompanies.com



Integrated  
Real Estate  
Services



## Office Building For Lease

Nickels Arcade

326-330 S State St, Suite 226

Ann Arbor, MI 48104

217 SF

\$25.00 SF/yr (MG)

Available

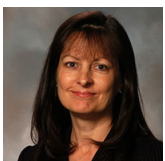

Contact Karen O'Neil for  
more information or to  
schedule a tour.

Office: 734.665.6500  
Cell: 734.323.4263  
koneil@oxfordcompanies.com

Nickels Arcade  
326-330 S State St, Suite 226  
Ann Arbor, MI 48104



Integrated  
Real Estate  
Services



## OFFERING SUMMARY

Lease Rate:	\$25.00 SF/yr (MG)
Short Term OXIO Rate:	\$600.00/mo
Available SF:	217 SF
Lot Size:	0.35 Acres
Year Built:	1917
Zoning:	D1
Submarket:	Washtenaw W of 23

## PROPERTY OVERVIEW

Nickels Arcade is one of Ann Arbor's most iconic landmarks, and offers both office and retail suites that offer tremendous differentiation in the downtown core of the city. Located downtown and directly across the street from University of Michigan's central campus, Nickels Arcade is one Ann Arbor's most beloved and frequented locations. The building's unique architecture and charm add to consistent foot traffic and tremendous visibility. Tenants at Nickels Arcade benefit from their proximity to other popular shops and restaurants and the community of businesses at this landmark property.

## PROPERTY HIGHLIGHTS

- Landmark downtown Ann Arbor structure
- Covered walkway between S. State and Maynard
- Located across from U of M campus
- Retail shops on the street level with 2 floors of office spaces above

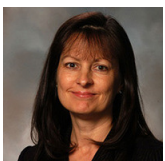

Contact Karen O'Neil for more information or to schedule a tour.

Office: 734.665.6500  
Cell: 734.323.4263  
koneil@oxfordcompanies.com

Nickels Arcade

326-330 S State St, Suite 226

Ann Arbor, MI 48104



Integrated  
Real Estate  
Services

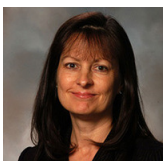
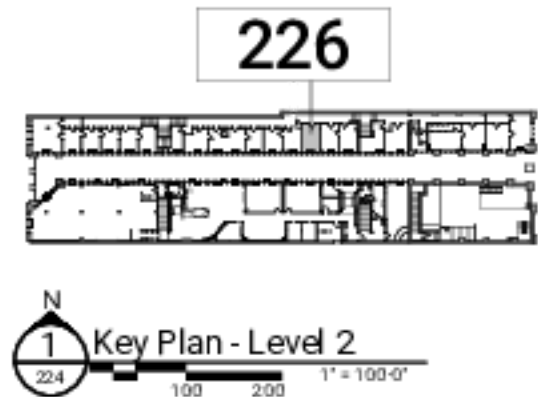
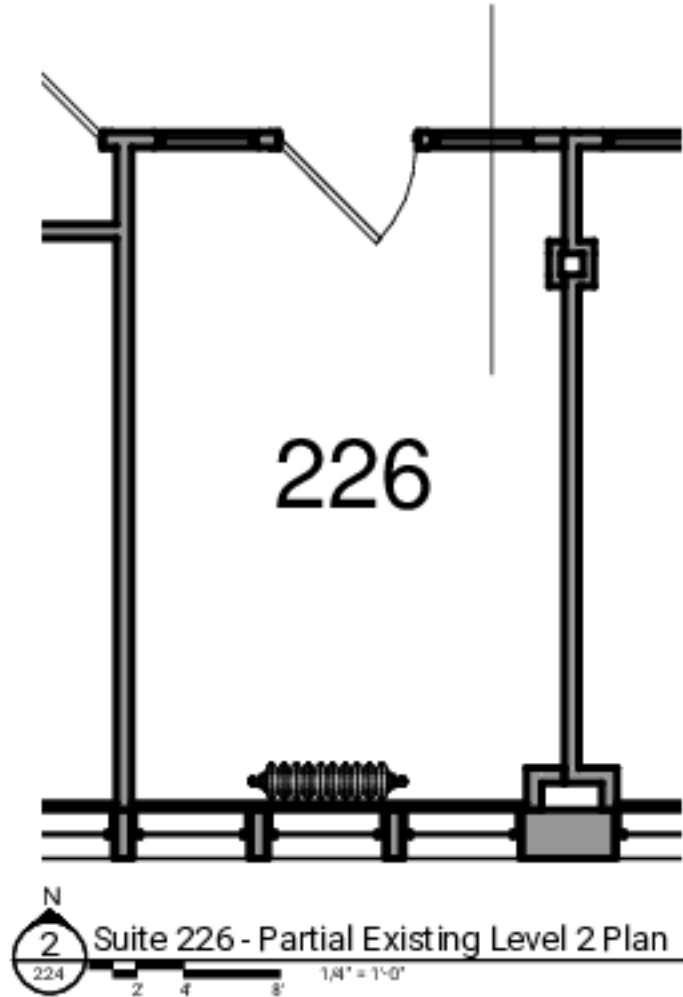

Contact Karen O'Neil for  
more information or to  
schedule a tour.

Office: 734.665.6500  
Cell: 734.323.4263  
koneil@oxfordcompanies.com

Nickels Arcade

326-330 S State St, Suite 226

Ann Arbor, MI 48104



Integrated  
Real Estate  
Services

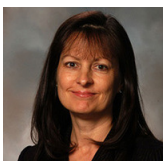
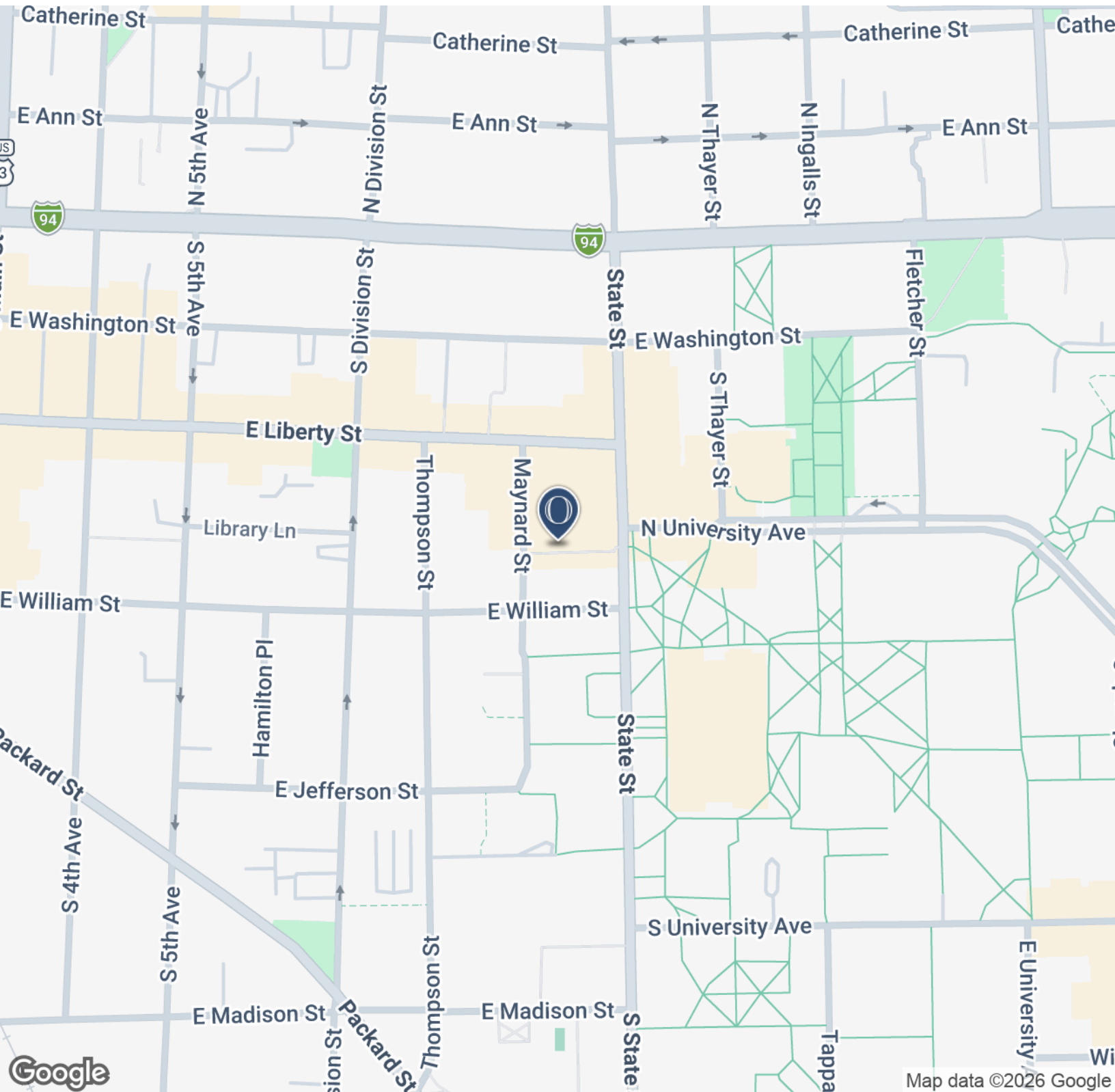

Contact Karen O'Neil for  
more information or to  
schedule a tour.

Office: 734.665.6500  
Cell: 734.323.4263  
koneil@oxfordcompanies.com

Nickels Arcade  
 326-330 S State St, Suite 226  
 Ann Arbor, MI 48104



Integrated  
 Real Estate  
 Services

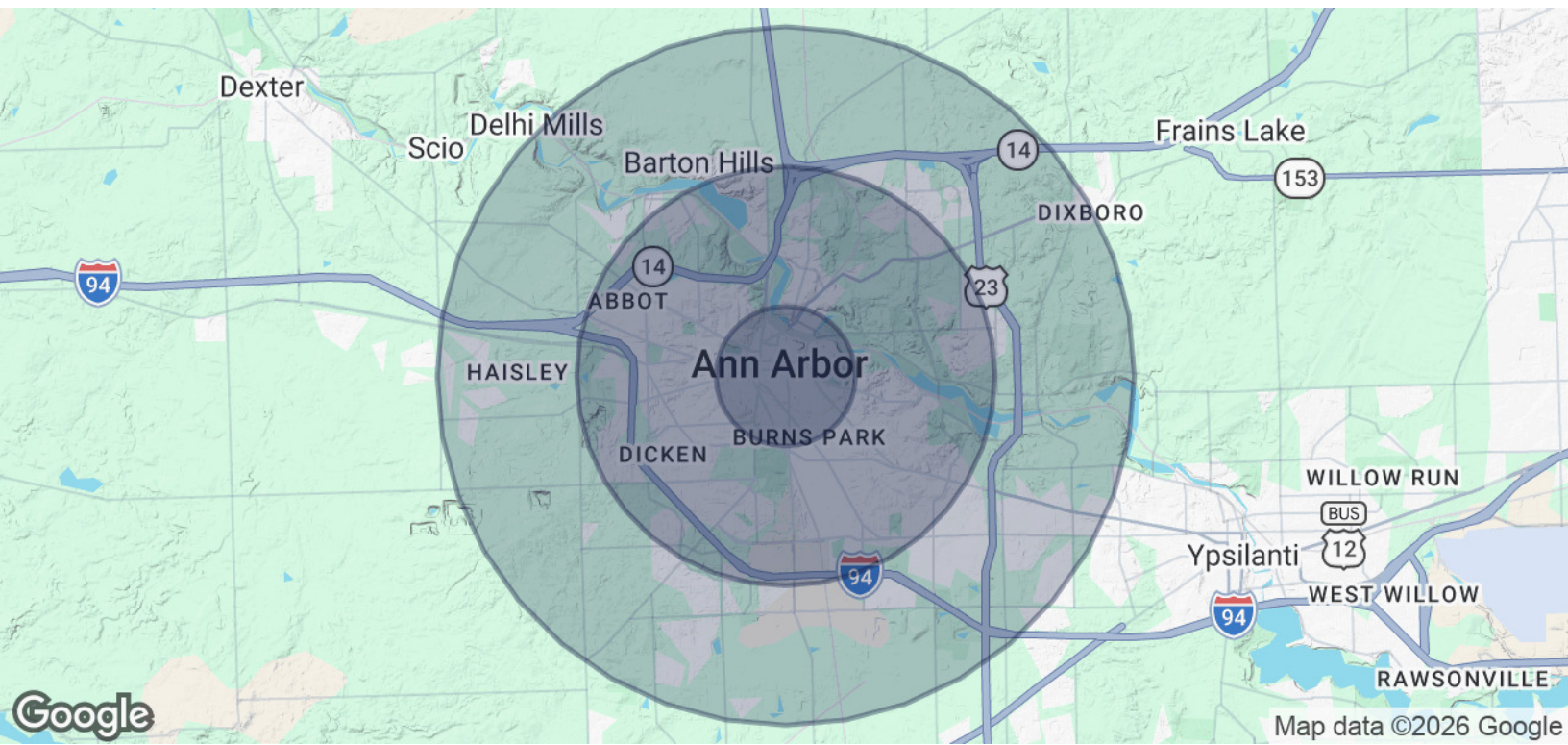

<b>POPULATION</b>	<b>1 MILE</b>	<b>3 MILES</b>	<b>5 MILES</b>
Total Population	35,450	108,651	165,717
Average Age	28	35	37
Average Age (Male)	28	35	36
Average Age (Female)	28	36	38
<b>HOUSEHOLDS &amp; INCOME</b>	<b>1 MILE</b>	<b>3 MILES</b>	<b>5 MILES</b>
Total Households	12,488	44,193	69,092
# of Persons per HH	2.8	2.5	2.4
Average HH Income	\$72,572	\$119,934	\$125,202
Average House Value	\$551,987	\$536,837	\$496,675

\* Demographic data derived from 2020 ACS - US Census

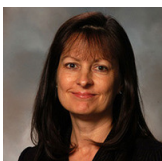

Contact Karen O'Neil for more information or to schedule a tour.

Office: 734.665.6500  
 Cell: 734.323.4263  
[koneil@oxfordcompanies.com](mailto:koneil@oxfordcompanies.com)