

Available SF 2,000 SF

Industrial For Lease

Building Size 19,100 SF

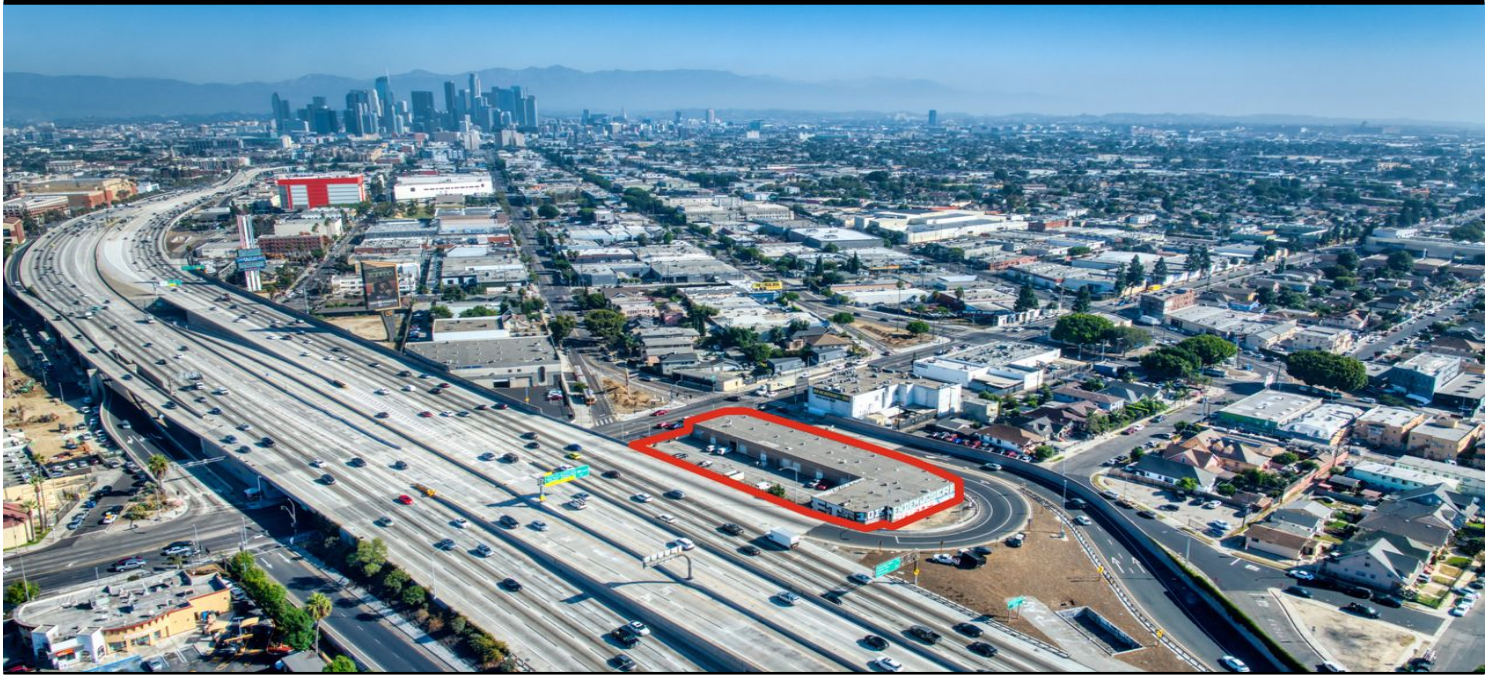

Property Name: King Industrial Center
Address: 380 W Martin Luther King Jr Blvd, Unit 2, Los Angeles, CA 90037
Cross Streets: S Hill/W Martin Luther King Jr Blvd

Modern Multi-Tenant Industrial Park
 Sprinklers - Foil - 4 Car Gated/Reserved Parking
 Separately Metered Power
 Minutes to DTLA, USC, Colosseum & BMO Stdm
 110 Fwy Adjacent

Lease Rate/Mo: \$2,900	Sprinklered: Yes	Office SF / #: 240 SF / 1
Lease Rate/SF: \$1.45	Clear Height: 14'	Restrooms: 1
Lease Type: Gross	GL Doors/Dim: 1 / 10'x11'	Office HVAC: Heat & AC
Available SF: 2,000 SF	DH Doors/Dim: 0	Finished Ofc Mezz: 0 SF
Minimum SF: 2,000 SF	A: 100 V: 120/208 O: 3 W: 4	Include In Available: No
Prop Lot Size: POL	Construction Type: Concrete	Unfinished Mezz: 0 SF
Term: 1-3 Years + Increases	Const Status/Year Blt: Existing / 1985	Include In Available: No
Sale Price: NFS	Whse HVAC:	Possession: 08/01/2026
Sale Price/SF: NFS	Parking Spaces: 4 / Ratio: 2.0:1/	Vacant: No
Taxes:	Rail Service: No	To Show: Call broker
Yard: Fenced/Paved	Specific Use: Warehouse/Office	Market/Submarket: Outlying Los Angeles
Zoning: M1-1-CPIO		APN#: 5111-003-012,5111-003-036

Listing Company: Sterling Industrial Realty, Inc
Agents: [Brad Harris 213-448-3313](mailto:Brad.Harris@sterlingprops.com)

Listing #: 44970466 **Listing Date:** 05/28/2026 **FTCF:** CB300Y175S000/A0AA

Notes: Lessee to independently verify all information herein. Contact Brad Harris 213-448-3313 bharris@sterlingprops.com to show.

King Industrial Center
380 W.
Martin Luther King Jr. Blvd.
Los Angeles, CA 90037



Contact Exclusive Agent:
Brad S. Harris
bharris@sterlingprops.com
Cell: 213-448-3313
213-483-3601
1625 W. Olympic Blvd.
Suite 735
Los Angeles, CA 90015

W. Martin Luther King Jr. Blvd.

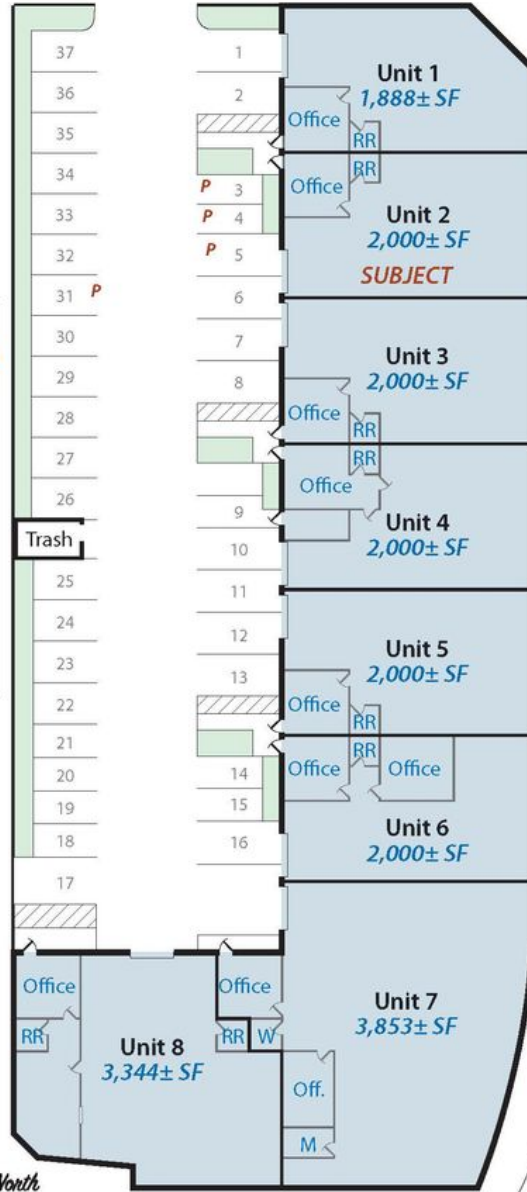

North Bound I-110 On-Ramp



The information contained herein is from sources we believe to be reliable but, we do not guarantee its accuracy. All measurements & dimensions are approximations and are not to scale. Clients are encouraged to verify their accuracy.



Brad Harris
bharris@sterlingprops.com
213-448-3313

