



BRAND NEW DOLLAR GENERAL WITH RENT BUMPS!

ACTUAL SITE

7519 E MICHIGAN AVE., JACKSON, MI 49201

30445 Northwestern Highway, Suite 275
Farmington Hills, MI 48334
248.254.3410
fortisnetlease.com

BRYAN BENDER
MANAGING DIRECTOR
D: 248.419.3810
BBENDER@FORTISNETLEASE.COM

NEW DOLLAR GENERAL WITH RENT BUMPS

7519 E MICHIGAN AVE., JACKSON, MI 49201 



DISCLOSURE :

All materials and information received or derived from Fortis Net Lease (hereinafter collectively referred to as “FNL”), its directors, officers, agents, advisors, affiliates and/or any third party sources are provided without representation or warranty by FNL its directors, officers, agents, advisors, or affiliates as to completeness, veracity, or accuracy, condition of the property, compliance or lack of compliance with applicable governmental requirements, suitability, financial performance of the property, projected financial performance of the property for any party’s intended use or any and all other matters.

Neither FNL its directors, officers, agents, advisors, or affiliates makes any representation or warranty, express or implied, as to accuracy or completeness of the any materials or information provided, derived, or received. Materials and information from any source, whether written or verbal, that may be furnished for review are not a substitute for a party’s active conduct of its own due diligence to determine these and other matters of significance to such party. FNL will not investigate or verify any such matters or conduct due diligence for a party unless otherwise agreed in writing.

ALL PARTIES SHALL CONDUCT THEIR OWN INDEPENDENT INVESTIGATION AND DUE DILIGENCE:

Any party contemplating or under contract or in escrow for a transaction is urged to verify all information and to conduct their own inspections and investigations including through appropriate third party independent professionals selected by such party.

All financial data should be verified by the party including by obtaining and reading applicable documents and reports and consulting appropriate independent professionals. FNL makes no warranties and/or representations regarding the veracity, completeness, or relevance of any financial data or assumptions. FNL does not serve as a financial advisor to any party regarding any proposed transaction. All data and assumptions regarding financial performance, including that used for financial modeling purposes, may differ from actual data or performance. Any estimates of market rents and/or projected rents that may be provided to a party do not necessarily mean that rents can be established at or increased to that level. Parties must evaluate any applicable contractual and governmental limitations as well as market conditions, vacancy factors and other issues in order to determine rents from or for the property.

Legal questions should be discussed by the party with an attorney. Tax questions should be discussed by the party with a certified public accountant or tax attorney. Title questions should be discussed by the party with a title officer or attorney. Questions regarding the condition of the property and whether the property complies with applicable governmental requirements should be discussed by the party with appropriate engineers, architects, contractors, other consultants and governmental agencies. All properties and services are marketed by FNL in compliance with all applicable fair housing and equal opportunity laws.

EXCLUSIVELY LISTED BY:

BRYAN BENDER

MANAGING DIRECTOR

D: 248.419.3810

BBENDER@FORTISNETLEASE.COM

NEW DOLLAR GENERAL WITH RENT BUMPS

7519 E MICHIGAN AVE., JACKSON, MI 49201 

INVESTMENT SUMMARY

| | |
|-------------------|--------------|
| List Price: | \$2,155,328 |
| Current NOI: | \$147,640.00 |
| Initial Cap Rate: | 6.85% |
| Land Acreage: | +/- 1.21 |
| Year Built | 2025 |
| Building Size: | 10,640 SF |
| Price PSF: | \$202.57 |
| Lease Type: | Absolute NNN |
| Lease Term: | 15 Years |
| Average CAP Rate: | 7.20% |

INVESTMENT OFFERING

Fortis Net Lease is pleased to present this 2025 BTS 10,640 SF. Dollar General Plus store located in Jackson, Michigan. The property is secured with a 15 year Absolute NNN Lease leaving zero landlord responsibilities. The lease contains 5% rental rate increases every 5 years including at each of the 5 (5 year) options to renew. The lease is corporately guaranteed by Dollar General Corporation which holds a credit rating of “BBB”, which is classified as Investment Grade. The store has completed construction and successfully opened for business in July 2025!

This Dollar General is highly visible as it is strategically positioned on the corner of Eastland Street & Michigan Avenue which sees 3,639 cars per day. This is the only dollar store serving the community! The 5 mile population from the site is 29,969 and the 1 mile average household income is \$84,775 per year, making this location ideal for a Dollar General. The Subject offering represents an ideal opportunity for a 1031 exchange buyer or a “passive” investor to attain the fee simple ownership of Dollar General. This investment will offer a new owner continued success due to the financial strength and the proven profitability of the tenant, the nation’s top dollar store. List price reflects a 6.85% cap rate based on NOI of \$147,640.



PRICE \$2,155,328



CAP RATE 6.85%



LEASE TYPE Absolute NNN



RENT INCREASES 5% Every 5 Years



TERM REMAINING 14.25 Years

INVESTMENT HIGHLIGHTS

- Brand New 15 Year Absolute NNN Lease
- **Zero Landlord Responsibilities**
- **2025 BTS Plus Size Construction | Now Open!**
- **Corner Location** | 3,639 Cars Per Day
- **5% Rental Rate Increases Every 5 Years!**
- 5 (5 Year) Options | 5% Increases At Each Option
- **1 Mile Household Income \$84,775**
- **5 Mile Population 29,969**
- **The Only Dollar Store Serving This Community!**
- Investment Grade Dollar Store With “BBB” Credit Rating
- **Dollar General Corporate Guaranty**

NEW DOLLAR GENERAL WITH RENT BUMPS

7519 E MICHIGAN AVE., JACKSON, MI 49201 

FINANCIAL SUMMARY

| INCOME | | PER SF |
|-----------------------------|---------------------|----------------|
| Rent | \$147,640.00 | \$13.88 |
| Gross Income | \$147,640.00 | \$13.88 |
| EXPENSE | | PER SF |
| Expenses | \$0 | \$0.00 |
| Gross Expenses | \$0 | \$0.00 |
| NET OPERATING INCOME | \$0.00 | \$0.00 |

PROPERTY SUMMARY

| | |
|---------------------|----------------|
| Year Built: | 2025 |
| Lot Size: | +/- 1.21 Acres |
| Building Size: | 10,640 SF |
| Traffic Count: | 7,065 VPD |
| Roof Type: | Standing Seam |
| Zoning: | Commercial |
| Construction Style: | Prototype |
| Parking Lot: | Asphalt |
| # of Parking Spaces | 45 |
| Warranties | Construction |
| HVAC | Roof Mounted |

LEASE SUMMARY

| | |
|----------------------------|--|
| Tenant: | Dollar General |
| Lease Type: | Absolute NNN |
| Primary Lease Term: | 15 Years |
| Annual Rent: | \$147,640.00 |
| Rent PSF: | \$13.88 |
| Landlord Responsibilities: | None |
| Taxes, Insurance & CAM: | Tenant Responsibility |
| Roof, Structure & Parking: | Tenant Responsibility |
| Lease Start Date: | 7/14/2025 |
| Lease Expiration Date: | 7/31/2040 |
| Lease Term Remaining: | 14.25 Years |
| Rent Bumps: | 5% Every 5 Years Including at Each Option |
| Renewal Options: | Five (5 Year) |
| Lease Guarantor: | Dollar General Corporation |
| Lease Guarantor Strength: | BBB |
| Tenant Website: | www.DollarGeneral.com |



GROSS SALES:
\$42.7 BILLION



STORE COUNT:
20,900+



GUARANTOR:
DG CORP



S&P:
BBB

NEW DOLLAR GENERAL WITH RENT BUMPS

7519 E MICHIGAN AVE., JACKSON, MI 49201 

| TENANT NAME | UNIT SIZE (SF) | LEASE START | LEASE END | ANNUAL RENT | % OF GLA | ESC DATE | RENT PER SF/YR |
|-----------------|----------------|-------------|-----------|---------------------|----------|----------|----------------|
| Dollar General | 10,640 | 7/14/2025 | 7/31/2040 | \$147,640.00 | 100.0 | - | \$13.88 |
| | | | | \$155,022.00 | | 8/1/2030 | \$14.57 |
| | | | | \$162,773.10 | | 8/1/2035 | \$15.30 |
| | | | | Option 1 | | 8/1/2040 | \$16.06 |
| | | | | Option 2 | | 8/1/2045 | \$16.87 |
| | | | | Option 3 | | 8/1/2050 | \$17.71 |
| Option 4 | 8/1/2055 | \$18.60 | | | | | |
| Option 5 | 8/1/2060 | \$19.52 | | | | | |
| Averages | 10,640 | | | \$155,145.03 | | | \$14.58 |

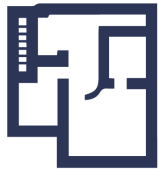

TOTAL SF
10,640



TOTAL ANNUAL RENT
\$147,640.00



OCCUPANCY RATE
100.0%



AVERAGE RENT/SF
\$14.58



NUMBER OF TENANTS
1



NEW DOLLAR GENERAL WITH RENT BUMPS

7519 E MICHIGAN AVE., JACKSON, MI 49201 

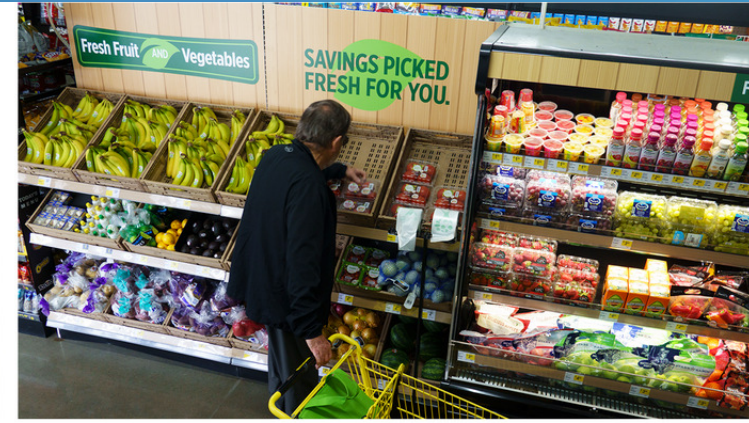

\$1.5 BILLION

2025 TOTAL NET INCOME



460 NEW STORES

OPENING IN 2026



\$42.7 BIL

2025 NET SALES



87 YEARS

IN BUSINESS



FORTUNE 500

ON LIST SINCE 2009

DOLLAR GENERAL is the largest “small box” discount retailer in the United States. Headquartered in Goodlettsville, TN, the BBB S&P rated company was established in 1939. There are more than 20,900+ stores with more than 195,000 employees, located across 48 states. Dollar General has more retail locations than any retailer in America. The Dollar General store format has typically been in rural and suburban markets, but now they are expanding into more densely populated areas. Dollar General opened 581 new stores in 2025, and planning to open an additional 460 in 2026. The Dollar General strategy is to deliver a hassle-free experience to customers, by providing a carefully edited assortment of the most popular brands in both retail and consumer products.



20,900+ STORES ACROSS 48 STATES

NEW DOLLAR GENERAL WITH RENT BUMPS

7519 E MICHIGAN AVE., JACKSON, MI 49201 

 FORTIS NET LEASE™



NEW DOLLAR GENERAL WITH RENT BUMPS

7519 E MICHIGAN AVE., JACKSON, MI 49201

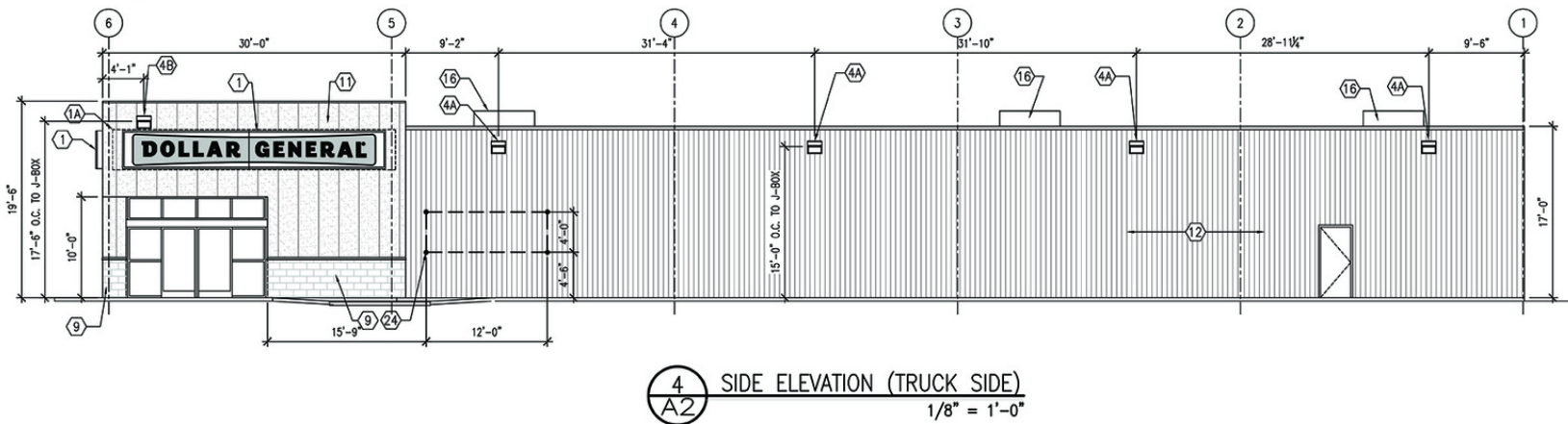
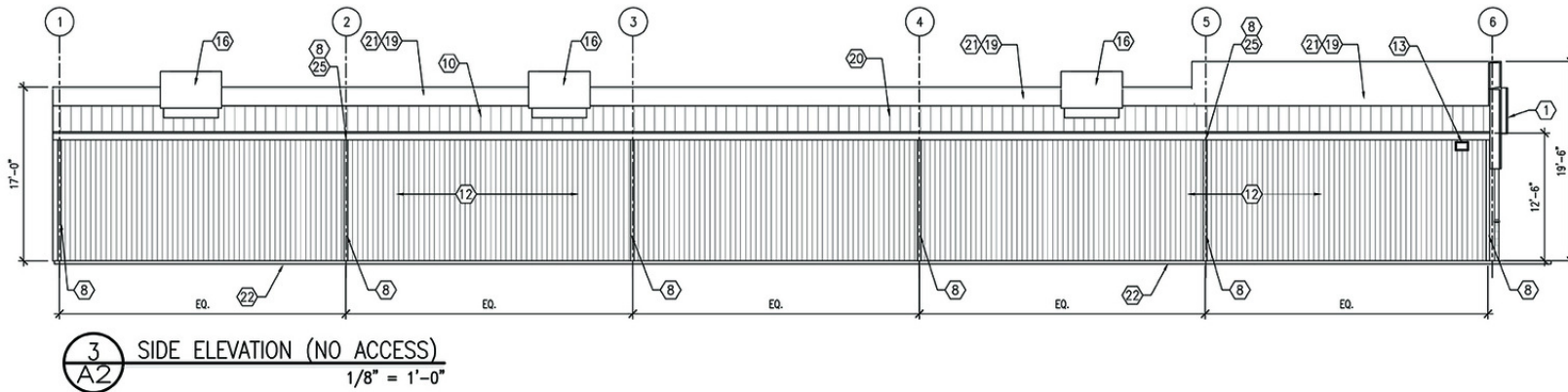
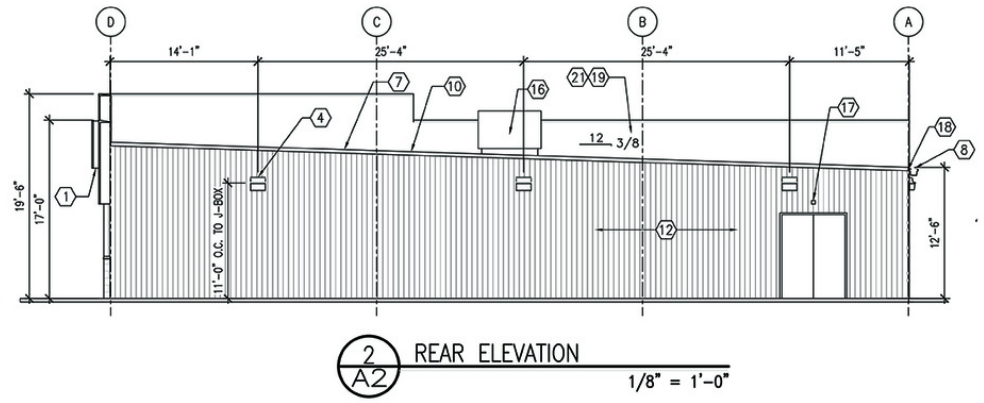
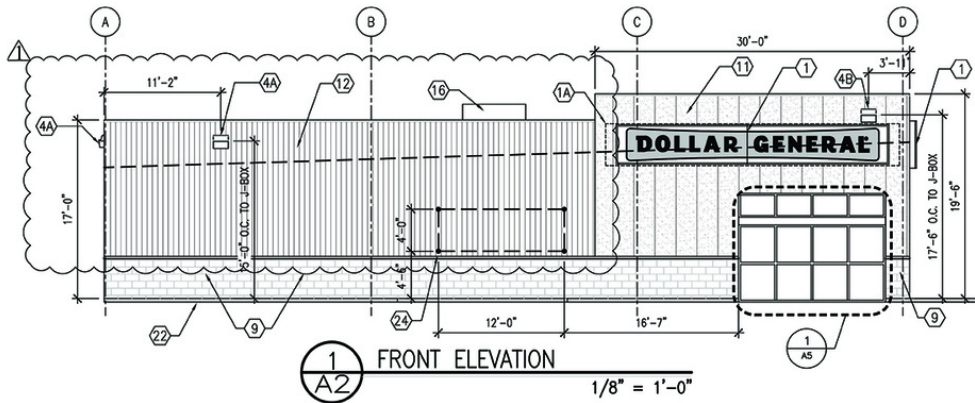

NEW DOLLAR GENERAL WITH RENT BUMPS

7519 E MICHIGAN AVE., JACKSON, MI 49201 



3,639 VPD E MICHIGAN AVE

EASTLAND ST

**DOLLAR
GENERAL**

NEW DOLLAR GENERAL WITH RENT BUMPS

7519 E MICHIGAN AVE., JACKSON, MI 49201 

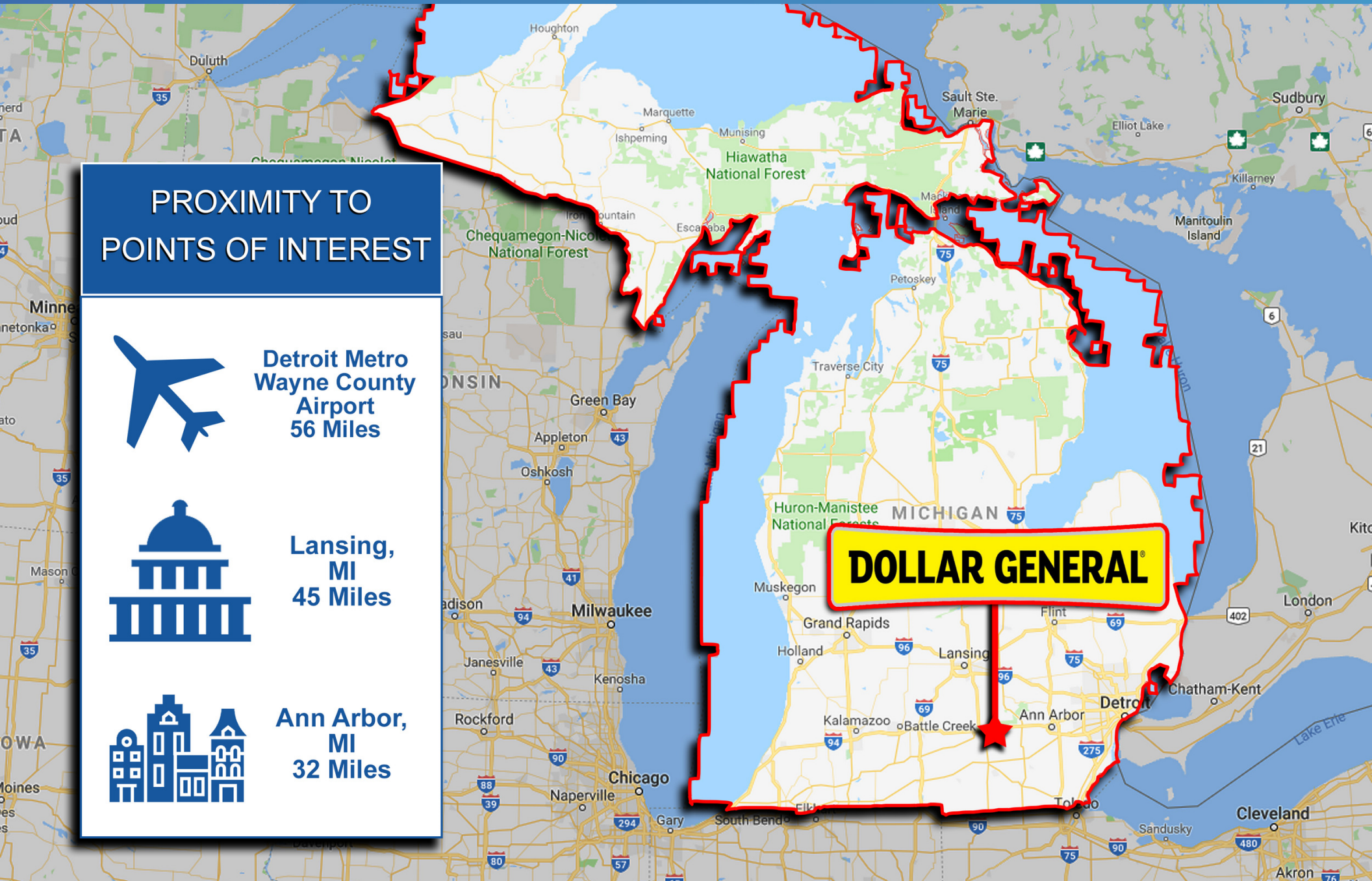

DOLLAR GENERAL®

PROXIMITY TO POINTS OF INTEREST



**Detroit Metro
Wayne County
Airport
56 Miles**



**Lansing,
MI
45 Miles**



**Ann Arbor,
MI
32 Miles**

NEW DOLLAR GENERAL WITH RENT BUMPS

7519 E MICHIGAN AVE., JACKSON, MI 49201 



NEW DOLLAR GENERAL WITH RENT BUMPS

7519 E MICHIGAN AVE., JACKSON, MI 49201

FORTIS NET LEASE™



NEW DOLLAR GENERAL WITH RENT BUMPS

7519 E MICHIGAN AVE., JACKSON, MI 49201

FORTIS NET LEASE™



NEW DOLLAR GENERAL WITH RENT BUMPS

7519 E MICHIGAN AVE., JACKSON, MI 49201

FORTIS NET LEASE™



Keicher Elementary School
Michigan Center Jr/Sr High School

DQ
Los Tres Amigos

Grande Golf Club

PAGE ONE Storage Sense
ALLEN FENCE COMPANY
Blue Water Pools OXFORDSHIRE
gerber COLLISION & GLASS
A & B CARPET CLEANING 919-413-3227
Passion

MENARDS
Rudy's
TC POWER SPORTS
BURGER KING
Kwik-JACKSON
Monster Motors.com
FUEL420

TITAN RESTORATION & RECOVERY

DEFUGGED COMPUTERS, LLC

SUBJECT PROPERTY
DOLLAR GENERAL

BEARD STATION

NEW DOLLAR GENERAL WITH RENT BUMPS

7519 E MICHIGAN AVE., JACKSON, MI 49201 



| POPULATION | 1 MILE | 3 MILES | 5 MILES |
|-----------------------|-----------|-----------|-----------|
| Total Population 2024 | 1,273 | 10,215 | 29,969 |
| Median Age | 42.7 | 43.4 | 40.6 |
| # Of Persons Per HH | 2.4 | 2.4 | 2.4 |
| HOUSEHOLDS & INCOME | 1 MILE | 3 MILES | 5 MILES |
| Total Households | 500 | 4,168 | 12,113 |
| Average HH Income | \$84,775 | \$79,411 | \$71,207 |
| Median House Value | \$158,767 | \$161,225 | \$132,893 |
| Consumer Spending | \$16.0 M | \$126.0 M | \$337.7 M |

Jackson, Michigan is a vibrant city located in south-central Michigan, about 40 miles west of Ann Arbor and 35 miles south of Lansing. Known as the birthplace of the Republican Party, Jackson is rich in historical significance and offers a mix of small-town charm and urban amenities. The downtown area features a growing arts and culture scene, with galleries, local shops, restaurants, and the historic Michigan Theatre.

Outdoor enthusiasts enjoy access to numerous parks and recreation areas, including Cascades Falls Park, which is home to a man-made waterfall and popular light shows. Jackson is also surrounded by scenic lakes and trails, making it a hub for boating, fishing, biking, and hiking.

With its blend of history, community spirit, and natural beauty, Jackson provides residents and visitors a welcoming and lively Midwestern experience.



FNL

TOTAL SALES VOLUME

\$10B+

PROPERTIES SOLD

4,500+

BROKER & BUYER REACH

400K+

STATES SOLD IN

46

Click to Meet Team Fortis

30445 Northwestern Highway, Suite 275
Farmington Hills, MI 48334
248.254.3410
fortisnetlease.com

EXCLUSIVELY LISTED BY:

BRYAN BENDER
MANAGING DIRECTOR
D: 248.419.3810
BBENDER@FORTISNETLEASE.COM