

THE PEAKE

BUILDING 9



DISCOVER THE PEAK.

PROPERTY INFORMATION

6225 N CLASSEN BLVD
Oklahoma City, OK 73118

BUILDING SIZE

± 77,039 SF

YEAR BUILT

2006

TOTAL FLOORS

7
(2 Sub / Basement)

OF OFFICES

246

LEASE RATE

\$25.00 NNN

FOR LEASE

Building 9 is built for organizations that think big. With large, efficient floor plates capable of accommodating sizeable teams, ample on-site parking, and a commanding street presence, Building 9 is ideally suited for an enterprise or regional headquarters. Its central location ensures easy access for employees, clients, and partners alike — while its adaptable layout gives your organization the room to grow, consolidate, and operate exactly the way you need to.



COMMERCIAL
OKLAHOMA

The Future of the Campus is Being Rewritten.

FLOOR PLANS

THE PEAKE

BUILDING 9

6225 N CLASSEN BLVD
Oklahoma City, OK 73118

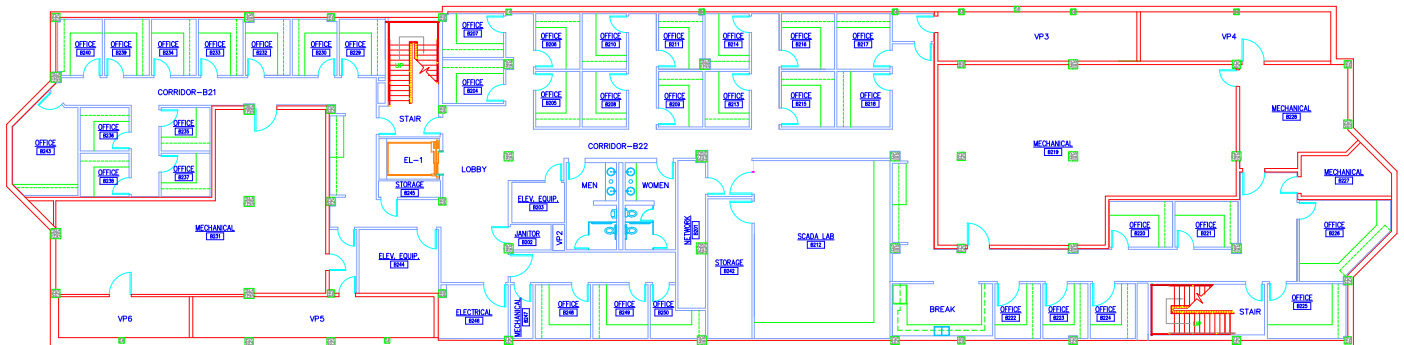

Sub-Basement I ± 7,775 SF Offices - 36

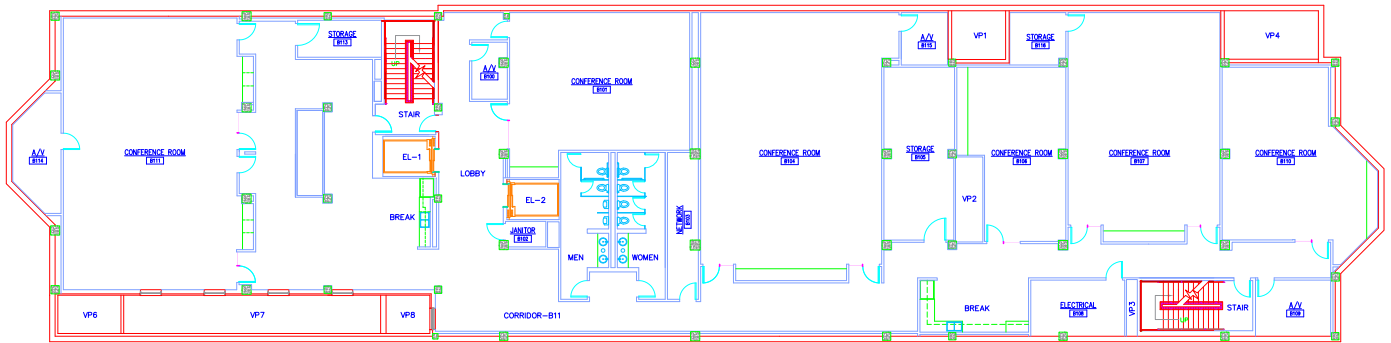

Basement I ± 12,707 SF Offices - 0

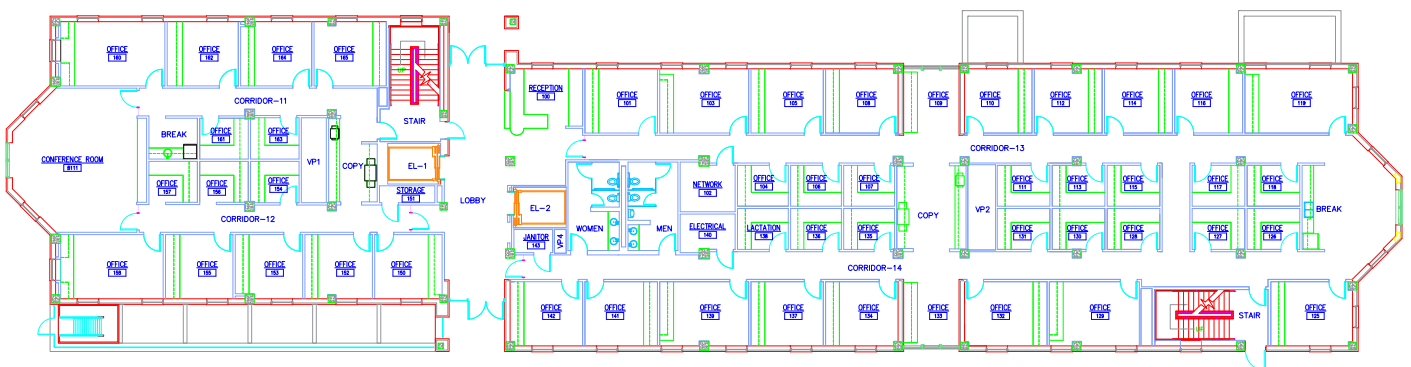

1st Floor I ± 12,580 SF Offices - 49

FLOOR PLANS

THE PEAKE

BUILDING 9

6225 N CLASSEN BLVD
Oklahoma City, OK 73118

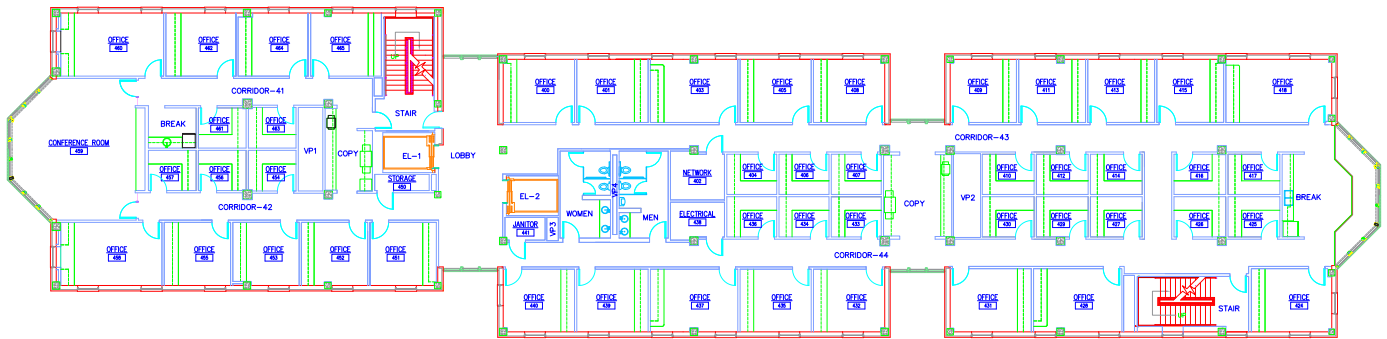

2nd Floor | ± 12,006 SF

Offices - 48

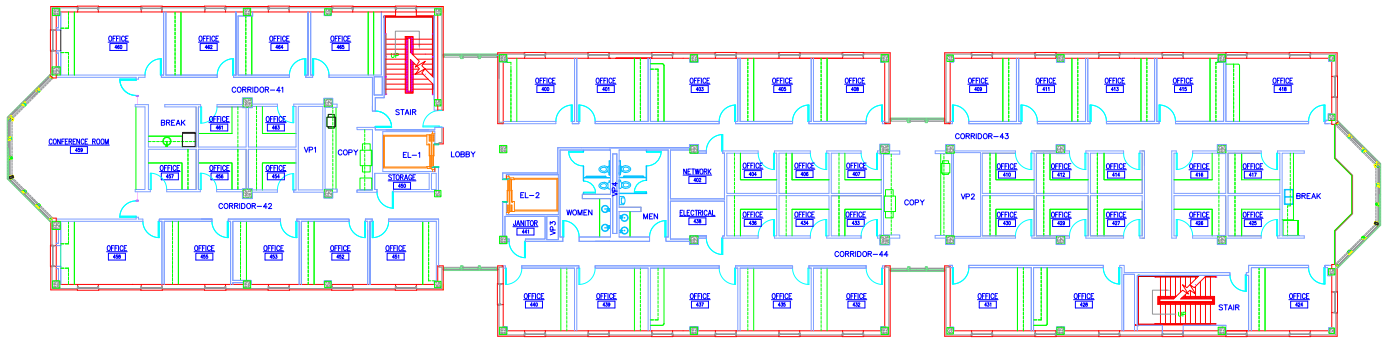

3rd Floor | ± 12,006 SF

Offices - 48

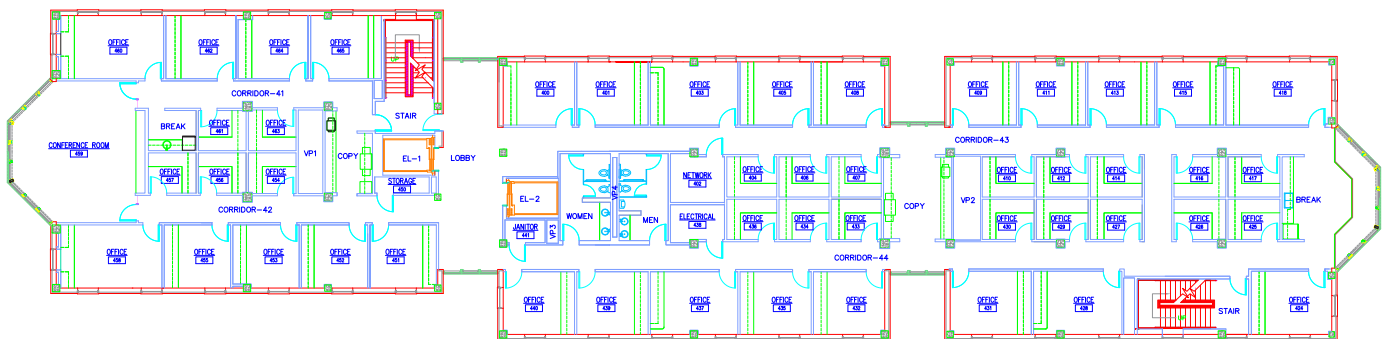

4th Floor | ± 12,006 SF

Offices - 48

FLOOR PLANS

THE PEAKE

BUILDING 9

6225 N CLASSEN BLVD
Oklahoma City, OK 73118

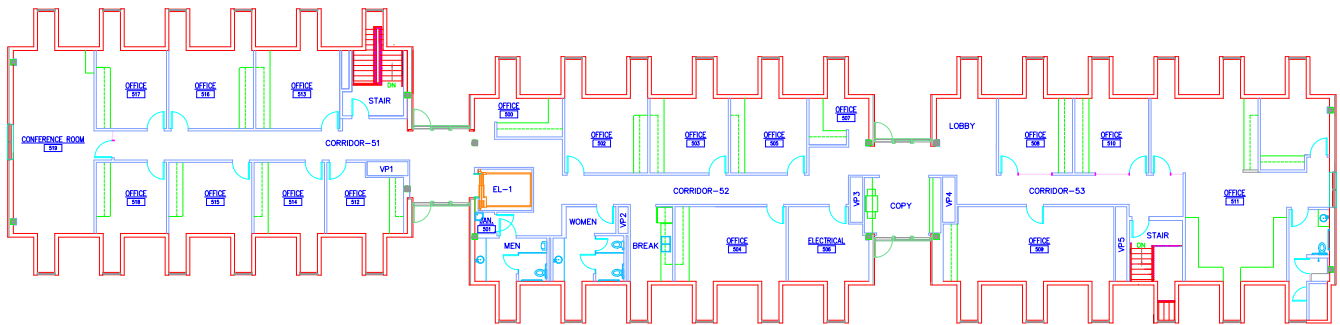

5th Floor | ± 7,959 SF

Offices - 17



BROKER CONTACT

TRAVIS MASON

+1 405 249 0655
tmason@commercialoklahoma.com

VIVIENNE VOGLER

+1 405 570 8595
vvoogler@commercialoklahoma.com



©2026 Cushman & Wakefield | Commercial Oklahoma. Independently Owned and Operated / A Member of the Cushman & Wakefield Alliance. All rights reserved. The material in this presentation has been prepared solely for information purposes, and is strictly confidential. Any disclosure, use, copying or circulation of this presentation (or the information contained within it) is strictly prohibited, unless you have obtained Cushman & Wakefield's prior written consent. The views expressed in this presentation are the views of the author and do not necessarily reflect the views of Cushman & Wakefield. Neither this presentation nor any part of it shall form the basis of, or be relied upon in connection with any offer, or act as an inducement to enter into any contract or commitment whatsoever. NO REPRESENTATION OR WARRANTY IS GIVEN, EXPRESS OR IMPLIED, AS TO THE ACCURACY OF THE INFORMATION CONTAINED WITHIN THIS PRESENTATION, AND CUSHMAN & WAKEFIELD IS UNDER NO OBLIGATION TO SUBSEQUENTLY CORRECT IT IN THE EVENT OF ERRORS.