

# 2267 W. Gowan Rd

North Las Vegas, NV 89032

## Industrial for Lease

1,279 – 1,282 SF



Yard Available

Leasing Information: 702.221.8226

**Ali Roesener, SIOR**  
NRE:S.0172338  
Senior Vice President  
(702) 765-8894  
Ali.Roesener@lpc.com

**Tony Alvarez**  
NRE:S.0200369  
Associate  
(702) 765-8880  
Tony.Alvarez@lpc.com

# Lincoln

4755 Dean Martin Drive  
Las Vegas, NV 89013

[www.lpc.com](http://www.lpc.com)

# 2267 W. Gowan Rd

North Las Vegas, NV 89032

## Industrial for Lease

1,279 – 1,282 SF

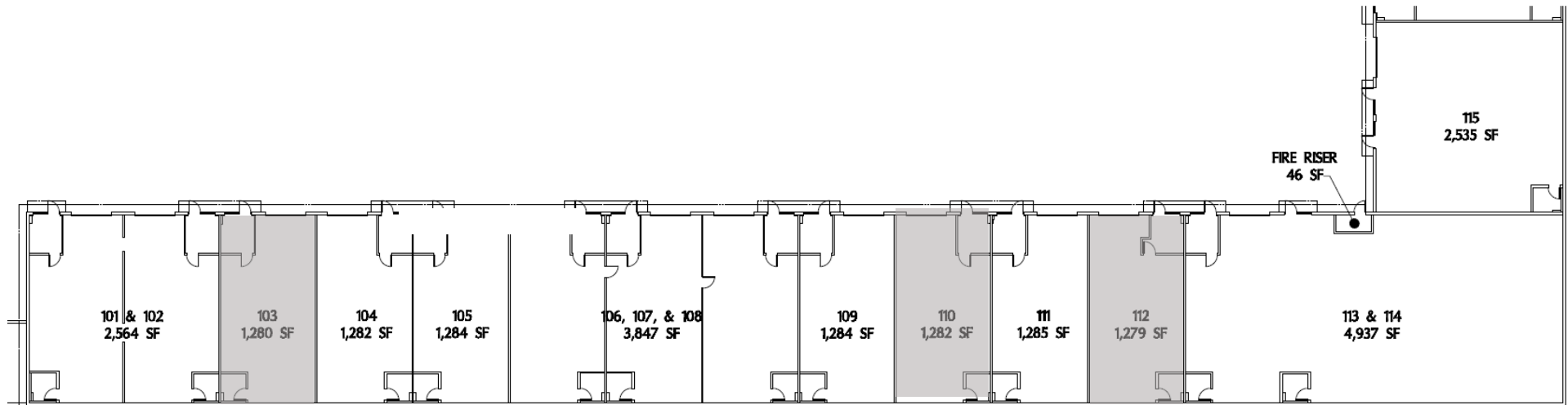

Suite	Total SF	Office SF	Warehouse SF	Dock	Grade	Rate	CAM	Monthly Total
103	1,280	190	1,090	0	1	\$0.98	\$0.34	\$1,689.60
110	1,282	189	1,093	0	1	\$0.98	\$0.34	\$1,692.24
112	1,279	198	1,081	0	1	\$0.98	\$0.34	\$1,688.28

**Ali Roesener, SIOR**  
(702) 765-8894  
Ali.Roesener@lpc.com

**Tony Alvarez**  
(702) 765-8880  
Tony.Alvarez@lpc.com

**Lincoln**

# 2267 W. Gowan Rd

North Las Vegas, NV 89032

## Industrial for Lease

1,279 – 1,282 SF

### SUITE 103

- 1,280 SF
- +/- 190 SF Office
- +/- 1,090 SF Warehouse
- 1 Grade Door 10' x 12'

### LEASING TERMS

- \$0.98 PSF Monthly NNN
- 5% Annual Increases
- \$0.34 PSF Monthly Operating Expenses

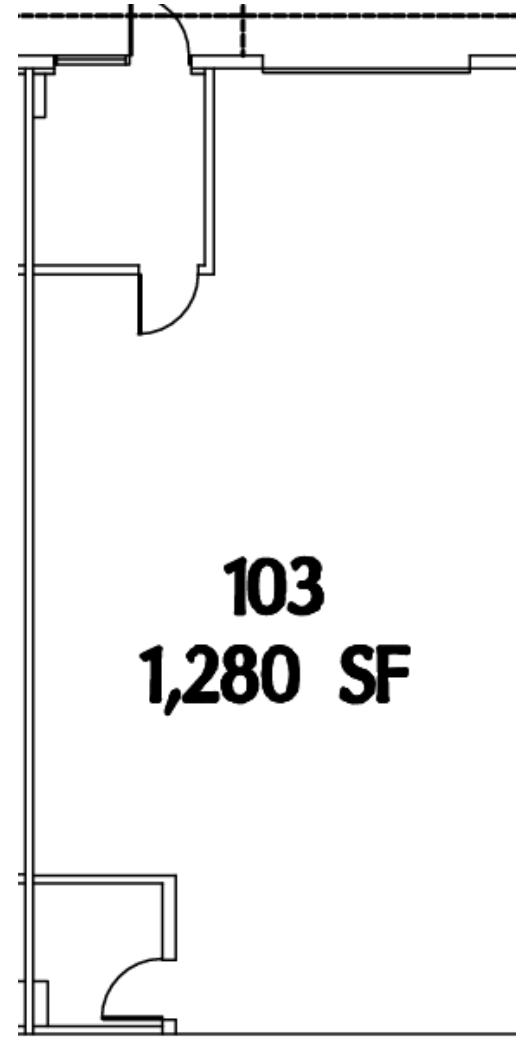

Ali Roesener, SIOR  
(702) 765-8894  
Ali.Roesener@lpc.com

Tony Alvarez  
(702) 765-8880  
Tony.Alvarez@lpc.com

**Lincoln**

# 2267 W. Gowan Rd

North Las Vegas, NV 89032

## Industrial for Lease

1,279 – 1,282 SF

### SUITE 110

- 1,282 SF
- +/- 189 SF Office
- +/- 1,093 SF Warehouse
- 1 Grade Door 10' x 12'

### LEASING TERMS

- \$0.98 PSF Monthly NNN
- 5% Annual Increases
- \$0.34 PSF Monthly Operating Expenses

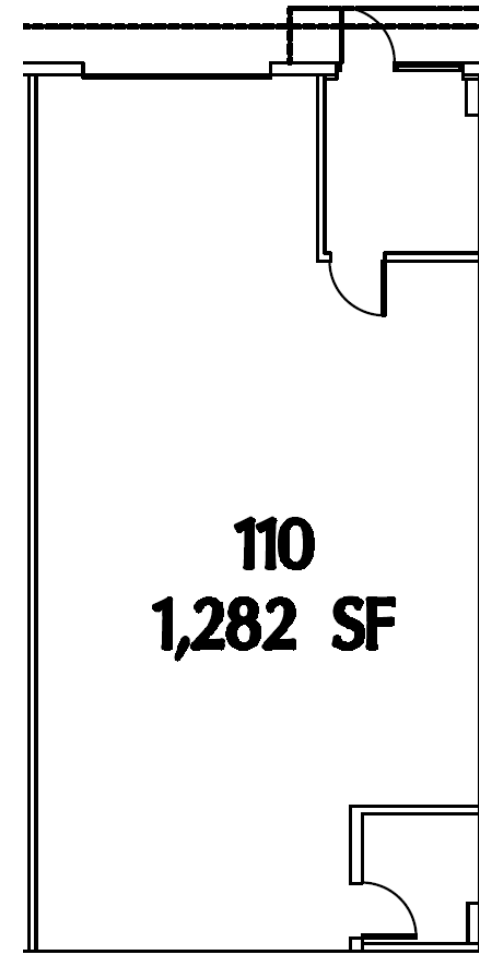

Ali Roesener, SIOR  
(702) 765-8894  
Ali.Roesener@lpc.com

Tony Alvarez  
(702) 765-8880  
Tony.Alvarez@lpc.com

**Lincoln**

# 2267 W. Gowan Rd

North Las Vegas, NV 89032

## Industrial for Lease

1,279 – 1,282 SF

### SUITE 112

- 1,279 SF
- +/- 198 SF Office
- +/- 1,081 SF Warehouse
- 1 Grade Door 10' x 12'

### LEASING TERMS

- \$0.98 PSF Monthly NNN
- 5% Annual Increases
- \$0.34 PSF Monthly Operating Expenses

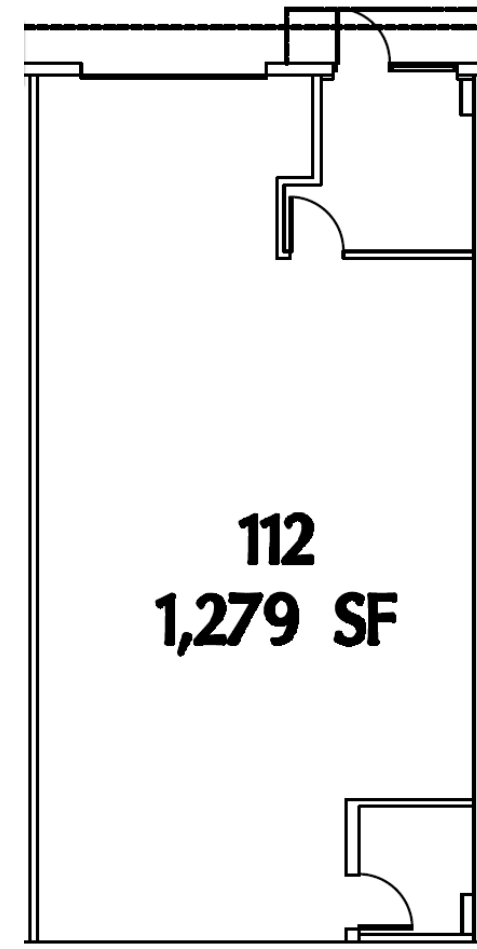

Ali Roesener, SIOR  
(702) 765-8894  
Ali.Roesener@lpc.com

Tony Alvarez  
(702) 765-8880  
Tony.Alvarez@lpc.com

**Lincoln**

# 2267 W. Gowan Rd

North Las Vegas, NV 89032

## Industrial for Lease

1,279 – 1,282 SF

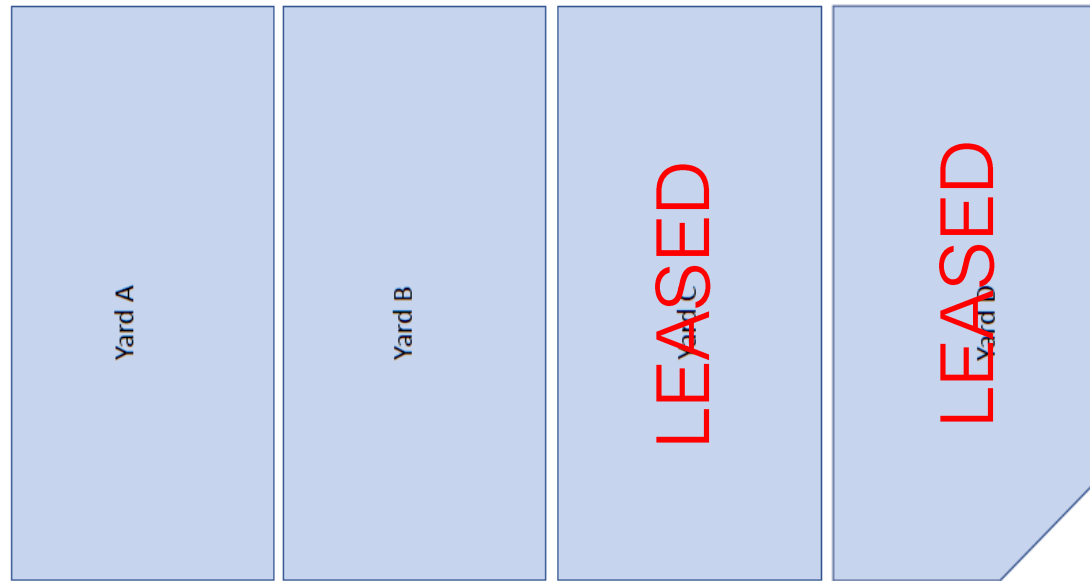

---

Yard	Square Feet	Asking	Total Monthly
A & B	3,744	\$0.45	\$1,684.80

---

**Ali Roesener, SIOR**  
(702) 765-8894  
Ali.Roesener@lpc.com

**Tony Alvarez**  
(702) 765-8880  
Tony.Alvarez@lpc.com

# Lincoln