

**Buildings 6 & 9**  
6301 Stassney Lane  
Austin, TX 78744

**For Lease**

Expo 6: 10,422 - 24,404 SF

Expo 9: 31,344 SF



Expo Business Park offers excellent visibility on Stassney Lane and is a premier location for distribution requiring quick access to major thoroughfares such as Highway 71, Highway 183, State Highway 130, and Interstate 35. Expo Business Park is also minutes from both the CBD and Austin-Bergstrom International Airport.

### BUILDING HIGHLIGHTS

- Total project size 417,388 SF
- Southeast submarket
- Concrete truck courts
- +/- 24' Clear height minimum
- Abundant parking
- City of Austin water and wastewater
- Austin Energy electricity
- ESFR Sprinklers
- Texas Gas Service
- AT&T telecommunication

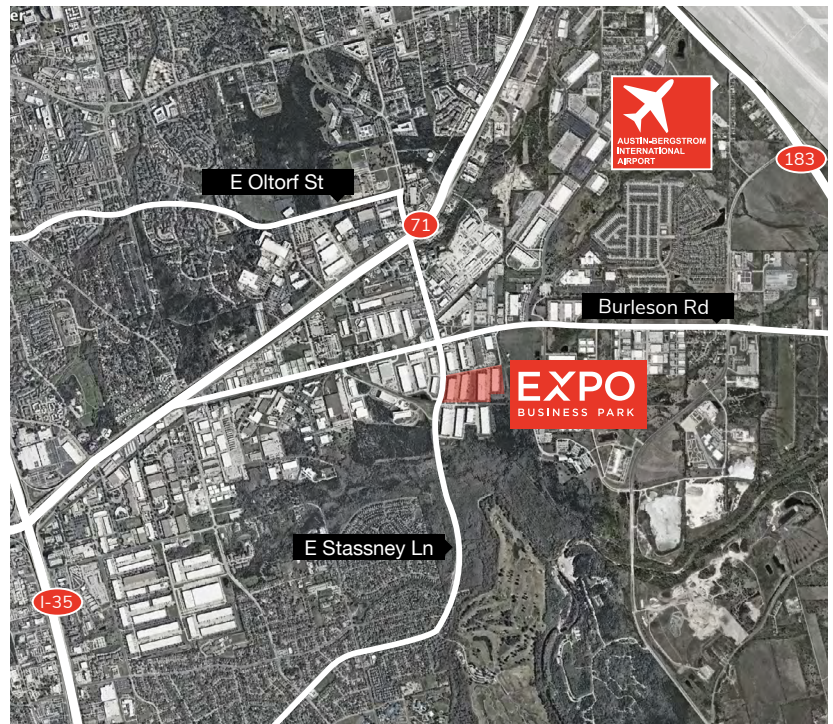

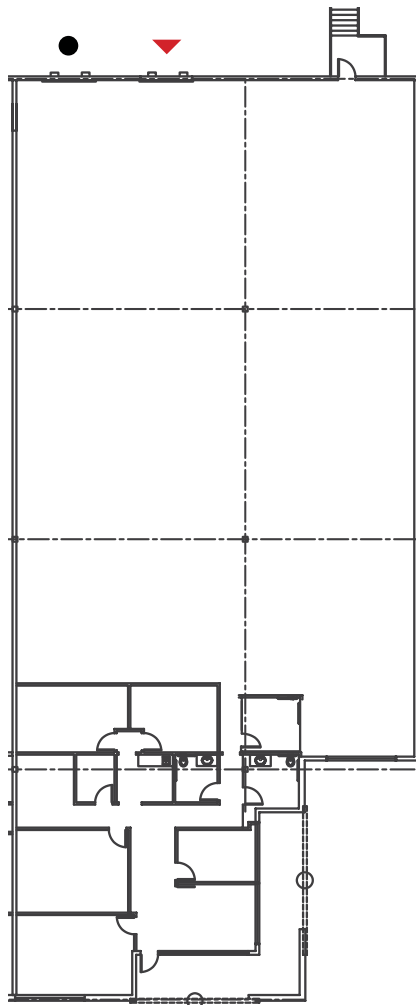

**Building 6 - Suite 100**

**10,422 SF Available**

**Endcap Suite**

**Office: 30%**

**Warehouse: 70%**

**Clear Height: +/- 24'**

**Building Depth: 160'**

**Column Spacing: 40' x 40'**

▲ 1 Dock-High Door

● 1 Ramp

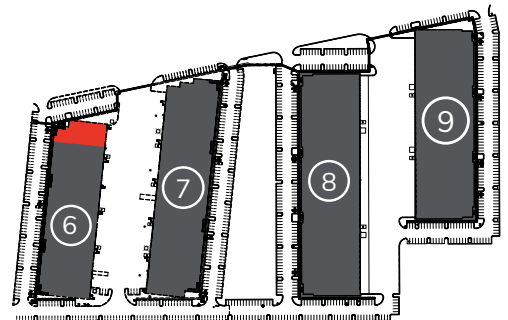



**Building 6 - Suite 600**

**24,404 SF Available**

**Endcap Suite**

**Office: 10% | 2,500 SF**

**Warehouse: 90% | 21,544 SF**

**Clear Height: +/- 24'**

**Building Depth: 160'**

**Column Spacing: 40' x 40'**

▲ 3 Dock-High Doors

● 1 Ramp

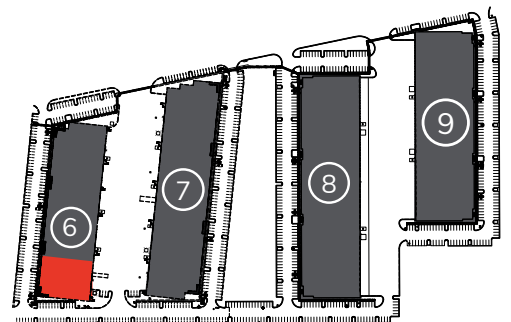
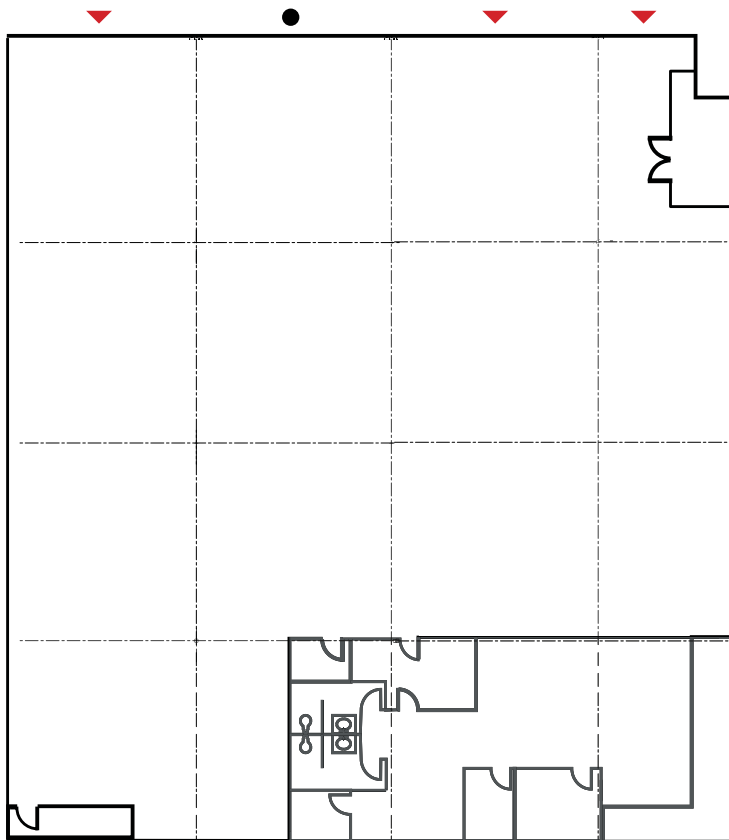

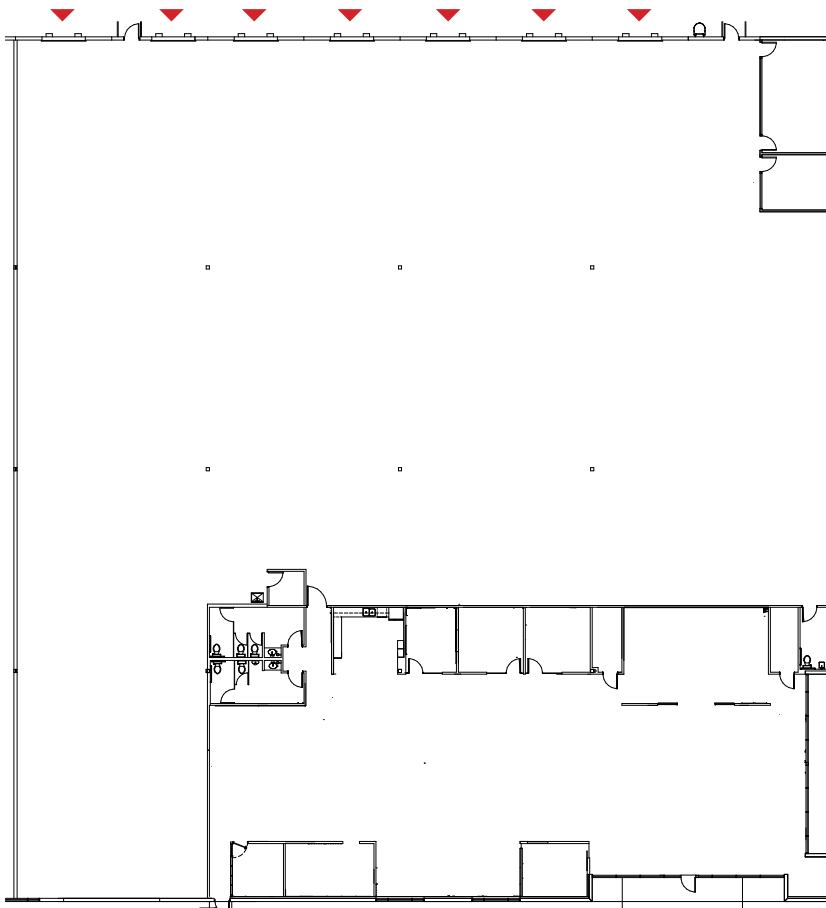

**Building 9 - Suite 100**

**31,344 SF Available**

**Endcap Suite**

**Office: 25% | 7,752 SF**

**Warehouse: 75% | 23,592 SF**

**Clear Height: +/- 24'**

**Building Depth: 180'**

**Column Spacing: 40' x 45'**

**▲ 7 Dock-High Doors**

[!\[\]\(626ce8ac21792b9405bfddfea8e0c96a\_img.jpg\) CLICK FOR VIRTUAL TOUR](#)

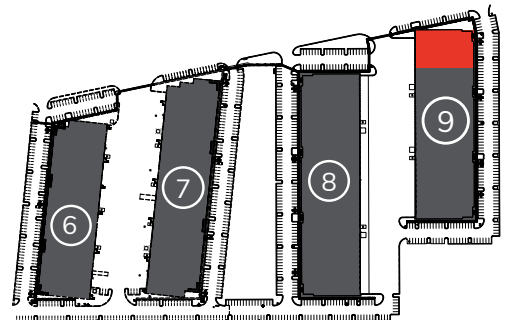



# EXPO

BUSINESS PARK

For more information on this opportunity, please contact:



Sam Owen  
512.481.3030  
sowen@streamrealty.com

Claudia Taylor  
512.481.3021  
claudia.taylor@streamrealty.com

[www.clarionpartners.com](http://www.clarionpartners.com)