

Buildings 6 & 9
6301 Stassney Lane
Austin, TX 78744

For Lease

Expo 6: 10,422 - 24,404 SF

Expo 9: 31,344 SF



Expo Business Park offers excellent visibility on Stassney Lane and is a premier location for distribution requiring quick access to major thoroughfares such as Highway 71, Highway 183, State Highway 130, and Interstate 35. Expo Business Park is also minutes from both the CBD and Austin-Bergstrom International Airport.

BUILDING HIGHLIGHTS

- Total project size 417,388 SF
- Southeast submarket
- Concrete truck courts
- +/- 24' Clear height minimum
- Abundant parking
- City of Austin water and wastewater
- Austin Energy electricity
- ESFR Sprinklers
- Texas Gas Service
- AT&T telecommunication

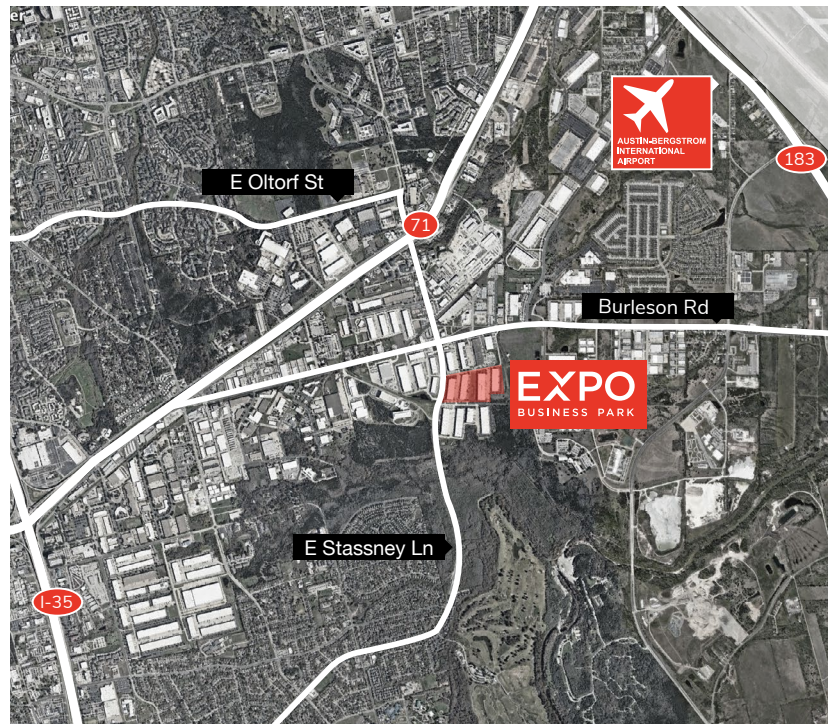

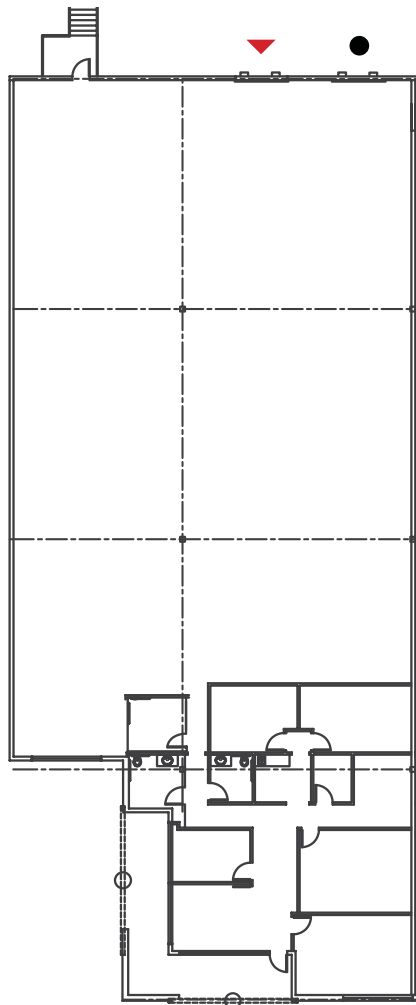

Building 6 - Suite 100

10,422 SF Available

Endcap Suite

Office: 30%

Warehouse: 70%

Clear Height: +/- 24'

Building Depth: 160'

Column Spacing: 40' x 40'

▲ 1 Dock-High Door

● 1 Ramp

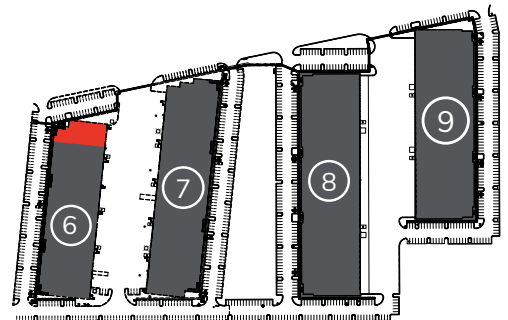



Building 6 - Suite 600

24,404 SF Available

Endcap Suite

Office: 10% | 2,500 SF

Warehouse: 90% | 21,544 SF

Clear Height: +/- 24'

Building Depth: 160'

Column Spacing: 40' x 40'

▲ 3 Dock-High Doors

● 1 Ramp

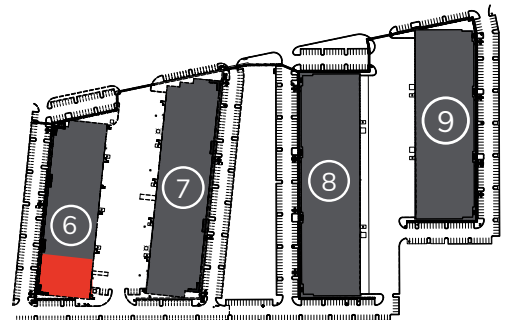
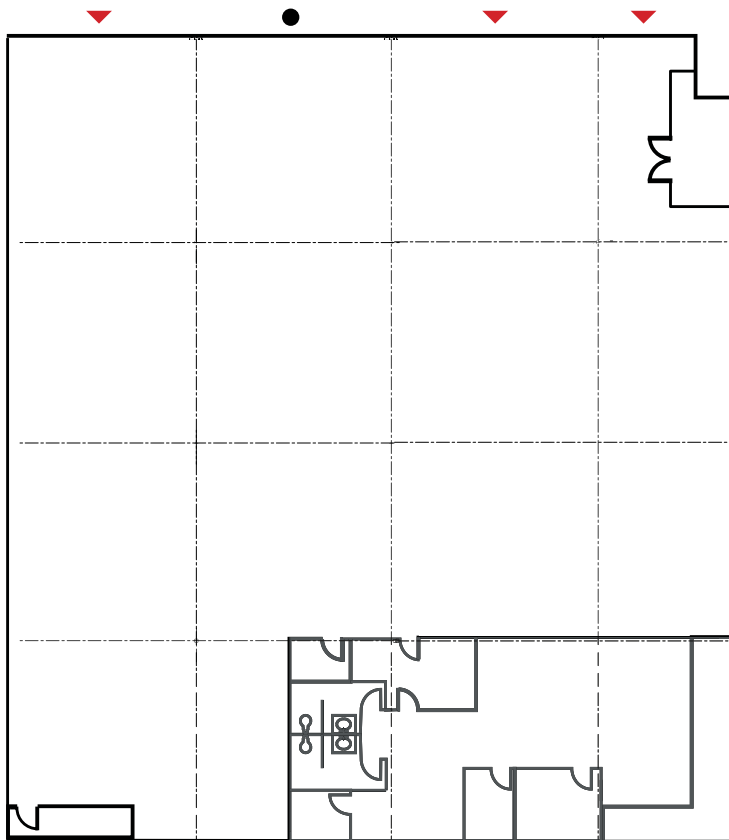

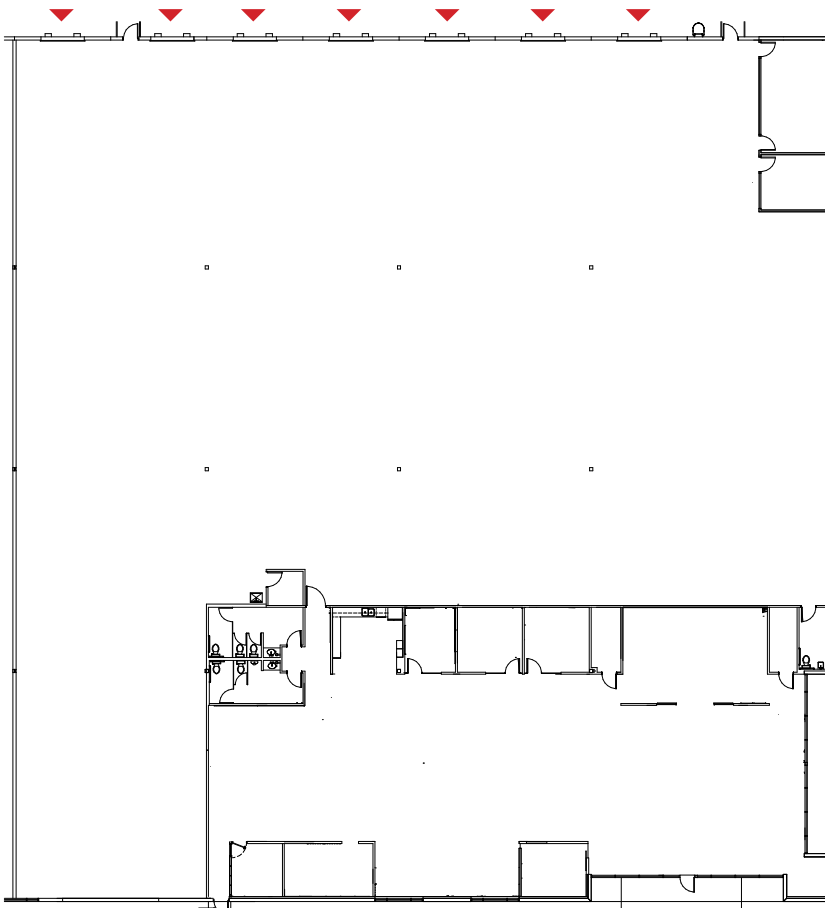

Building 9 - Suite 100

31,344 SF Available

Endcap Suite

Office: 25% | 7,752 SF

Warehouse: 75% | 23,592 SF

Clear Height: +/- 24'

Building Depth: 180'

Column Spacing: 40' x 45'

▲ 7 Dock-High Doors

[CLICK FOR VIRTUAL TOUR](#)

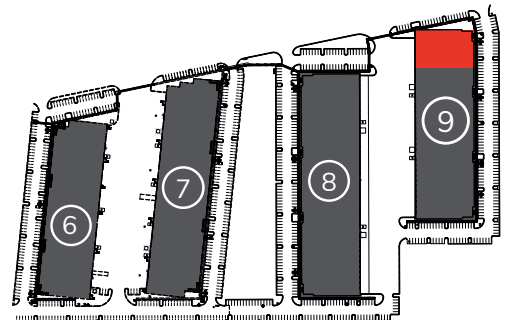



EXPO

BUSINESS PARK

For more information on this opportunity, please contact:



Sam Owen
512.481.3030
sowen@streamrealty.com

Claudia Taylor
512.481.3021
claudia.taylor@streamrealty.com

www.clarionpartners.com