

5266 Office Park Blvd

CREATED ON
May 23, 2026

LOCATION
5266 Office Park Boulevard
34203 Bradenton
Florida
US



Total area 2665.41 sq ft	Floors 1	Rooms 19	Conference room 0
------------------------------------	--------------------	--------------------	-----------------------------

5266 Office Park Blvd

5266 Office Park Boulevard, 34203 Bradenton, Florida, US
 TOTAL AREA: 2665.41 sq ft • LIVING AREA: 2665.41 sq ft • FLOORS: 1 • ROOMS: 19



▼ Ground Floor

TOTAL AREA: 2665.41 sq ft • LIVING AREA: 2665.41 sq ft • ROOMS: 19

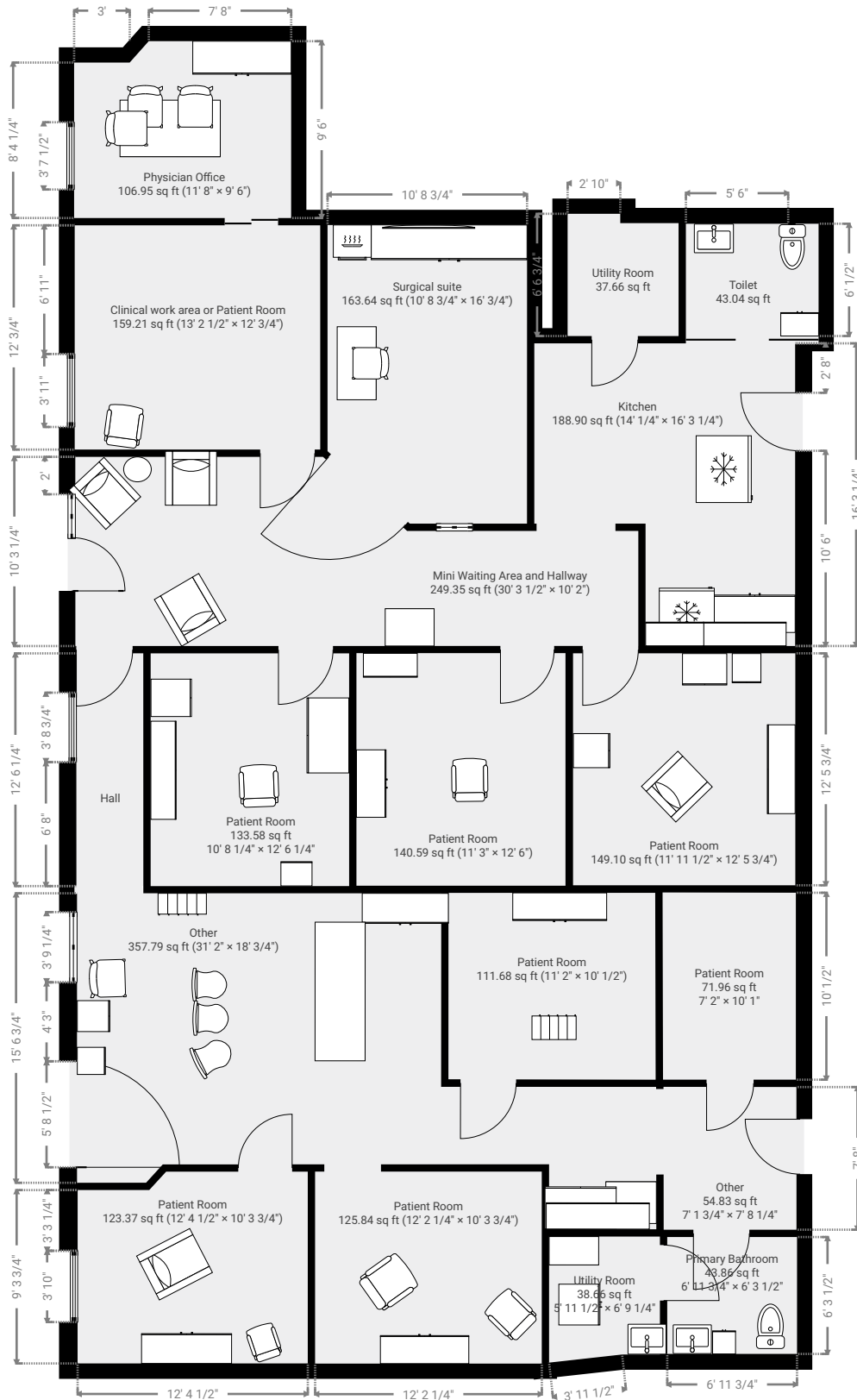

THIS FLOOR PLAN IS PROVIDED WITHOUT WARRANTY OF ANY KIND. SENSOPIA DISCLAIMS ANY WARRANTY INCLUDING, WITHOUT LIMITATION, SATISFACTORY QUALITY OR ACCURACY OF DIMENSIONS.



1:107

5266 Office Park Blvd

5266 Office Park Boulevard, 34203 Bradenton, Florida, US
TOTAL AREA: 2665.41 sq ft • LIVING AREA: 2665.41 sq ft • FLOORS: 1 • ROOMS: 19



▼ Clinical work area or Patient Room Ground Floor

WIDTH: 12' 3/4" • LENGTH: 13' 2 1/2" • CEILING HEIGHT: 9' 1/2"
AREA: 159.21 sq ft • PERIMETER: 50' 6 1/4"

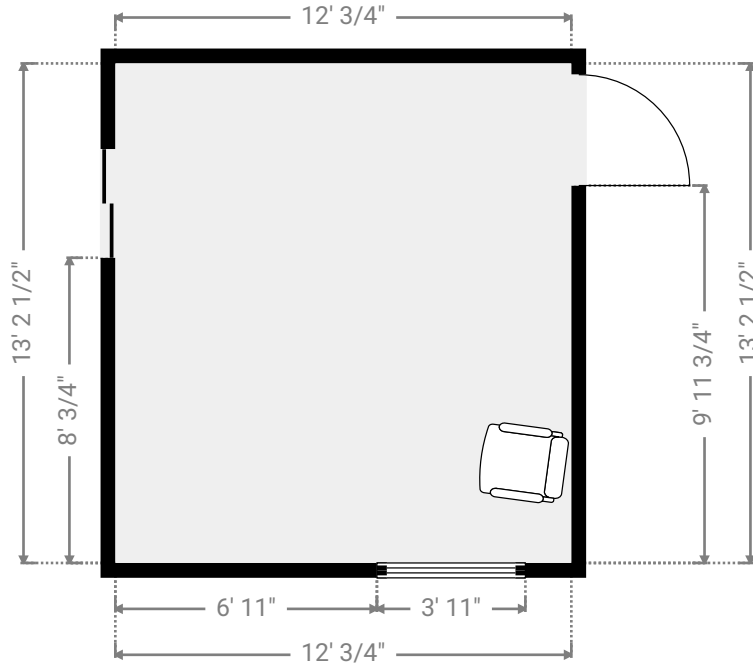
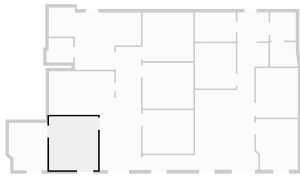

▼ Hall Ground Floor

WIDTH: 12' 6 1/4" • LENGTH: 3' 7 1/4" • CEILING HEIGHT: 9' 1/2"
AREA: 45.04 sq ft • PERIMETER: 32' 2 3/4"

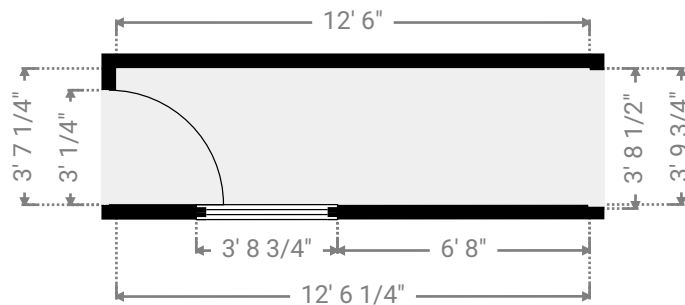

5266 Office Park Blvd

5266 Office Park Boulevard, 34203 Bradenton, Florida, US
 TOTAL AREA: 2665.41 sq ft • LIVING AREA: 2665.41 sq ft • FLOORS: 1 • ROOMS: 19



▼ Kitchen Ground Floor

WIDTH: 16' 3 1/4" • LENGTH: 14' 1/4" • CEILING HEIGHT: 10' 1 3/4"
 AREA: 188.90 sq ft • PERIMETER: 60' 7 1/4"

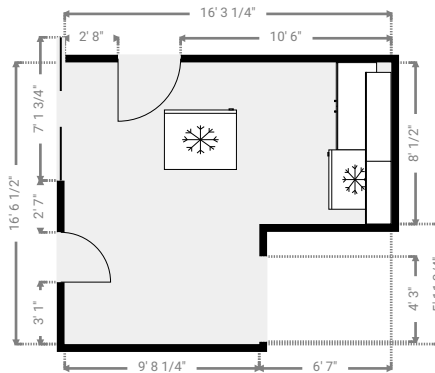
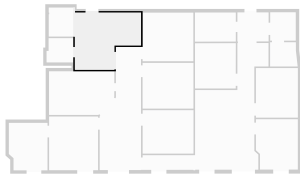

▼ Mini Waiting Area and Hallway Ground Floor

WIDTH: 10' 2" • LENGTH: 30' 3 1/2" • CEILING HEIGHT: 9' 1/2"
 AREA: 249.35 sq ft • PERIMETER: 78' 5"

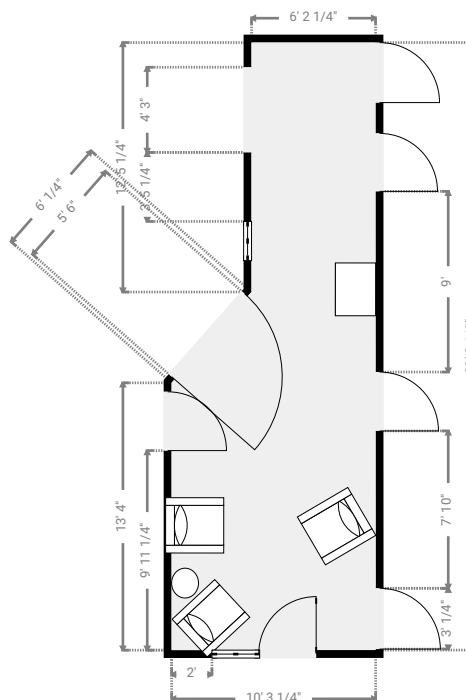
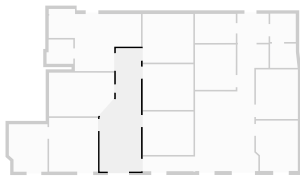

THIS FLOOR PLAN IS PROVIDED WITHOUT WARRANTY OF ANY KIND. SENSOPIA DISCLAIMS ANY WARRANTY INCLUDING, WITHOUT LIMITATION, SATISFACTORY QUALITY OR ACCURACY OF DIMENSIONS.



5266 Office Park Blvd

5266 Office Park Boulevard, 34203 Bradenton, Florida, US
TOTAL AREA: 2665.41 sq ft • LIVING AREA: 2665.41 sq ft • FLOORS: 1 • ROOMS: 19



▼ Other Ground Floor

WIDTH: 7' 8 1/4" • LENGTH: 7' 1 3/4" • CEILING HEIGHT: 9' 1/2"
AREA: 54.83 sq ft • PERIMETER: 29' 7 3/4"

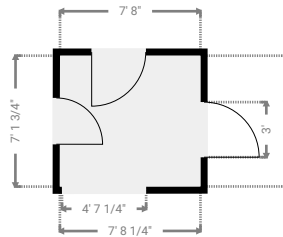
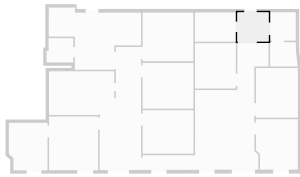

▼ Other Ground Floor

WIDTH: 18' 3/4" • LENGTH: 31' 2" • CEILING HEIGHT: 10' 1 3/4"
AREA: 357.79 sq ft • PERIMETER: 99' 10 1/4"

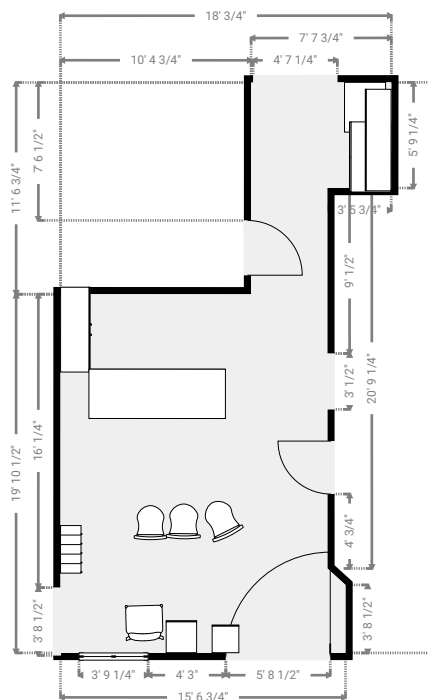
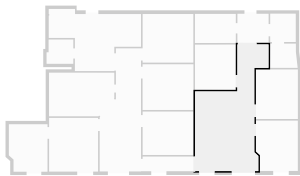

THIS FLOOR PLAN IS PROVIDED WITHOUT WARRANTY OF ANY KIND. SENSOPIA DISCLAIMS ANY WARRANTY INCLUDING, WITHOUT LIMITATION, SATISFACTORY QUALITY OR ACCURACY OF DIMENSIONS.

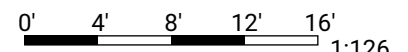

5266 Office Park Blvd

5266 Office Park Boulevard, 34203 Bradenton, Florida, US
TOTAL AREA: 2665.41 sq ft • LIVING AREA: 2665.41 sq ft • FLOORS: 1 • ROOMS: 19



▼ Patient Room Ground Floor

WIDTH: 12' 6" • LENGTH: 11' 3" • CEILING HEIGHT: 9' 1/2"
AREA: 140.59 sq ft • PERIMETER: 47' 6"

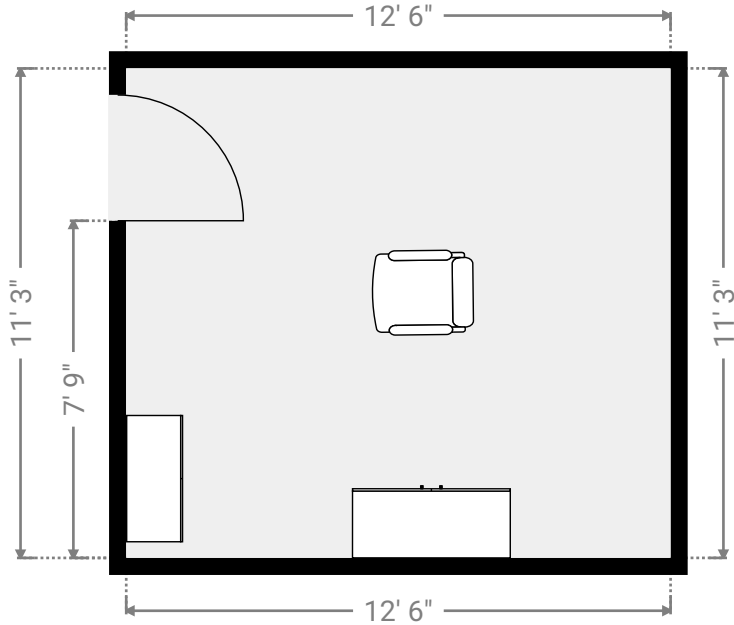
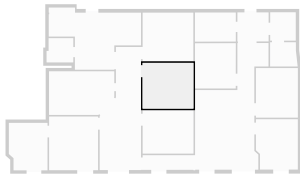

▼ Patient Room Ground Floor

WIDTH: 12' 5 3/4" • LENGTH: 11' 11 1/2" • CEILING HEIGHT: 9' 1/2"
AREA: 149.10 sq ft • PERIMETER: 48' 10 1/4"

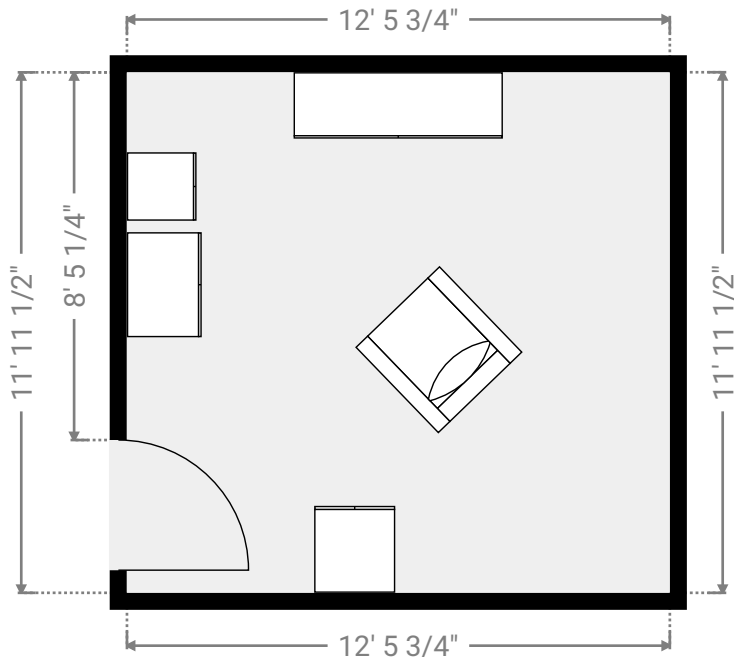
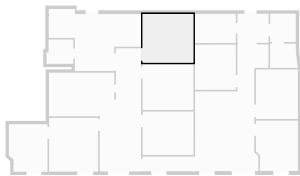

5266 Office Park Blvd

5266 Office Park Boulevard, 34203 Bradenton, Florida, US
TOTAL AREA: 2665.41 sq ft • LIVING AREA: 2665.41 sq ft • FLOORS: 1 • ROOMS: 19



▼ Patient Room Ground Floor

WIDTH: 12' 6 1/4" • LENGTH: 10' 8 1/4" • CEILING HEIGHT: 9' 1/2"
AREA: 133.58 sq ft • PERIMETER: 46' 4 1/2"

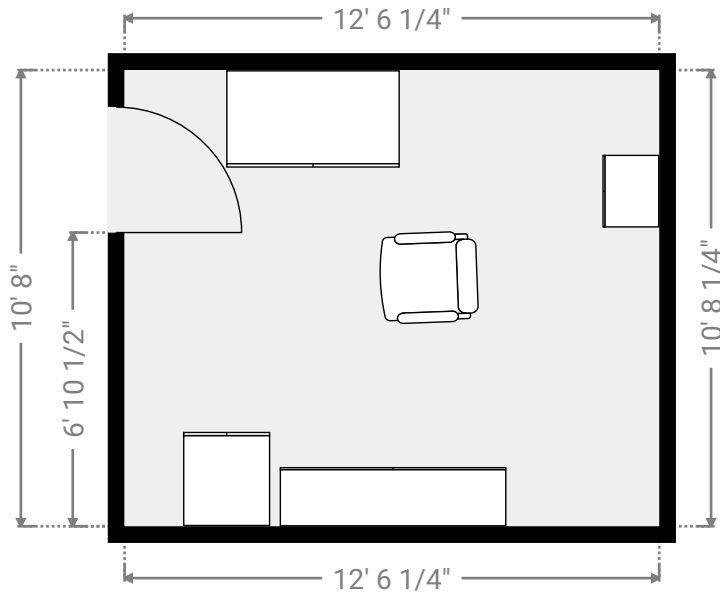
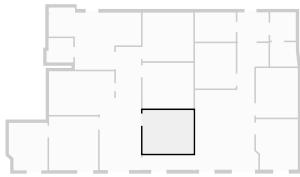

▼ Patient Room Ground Floor

WIDTH: 10' 3 3/4" • LENGTH: 12' 2 1/4" • CEILING HEIGHT: 10' 1 3/4"
AREA: 125.84 sq ft • PERIMETER: 45' 1/4"

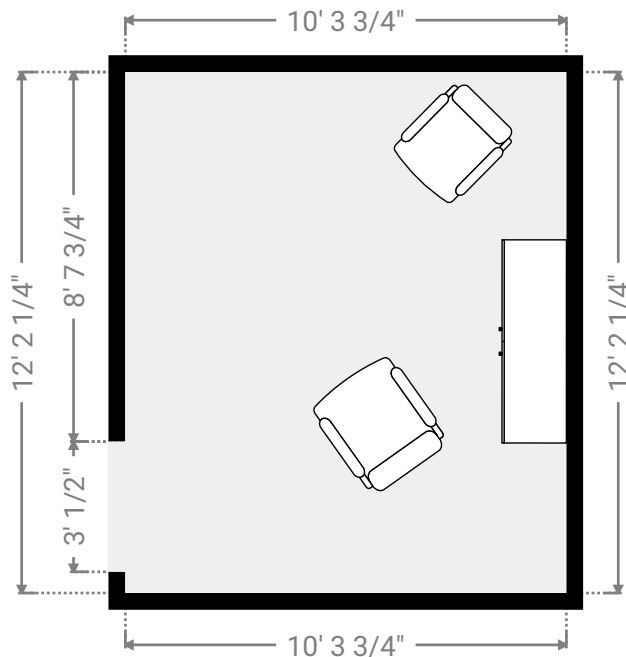
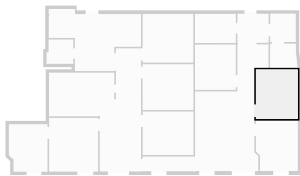

THIS FLOOR PLAN IS PROVIDED WITHOUT WARRANTY OF ANY KIND. SENSOPIA DISCLAIMS ANY WARRANTY INCLUDING, WITHOUT LIMITATION, SATISFACTORY QUALITY OR ACCURACY OF DIMENSIONS.



5266 Office Park Blvd

5266 Office Park Boulevard, 34203 Bradenton, Florida, US
TOTAL AREA: 2665.41 sq ft • LIVING AREA: 2665.41 sq ft • FLOORS: 1 • ROOMS: 19



▼ Patient Room Ground Floor

WIDTH: 10' 3 3/4" • LENGTH: 12' 4 1/2" • CEILING HEIGHT: 9' 1/2"
AREA: 123.37 sq ft • PERIMETER: 44' 10"

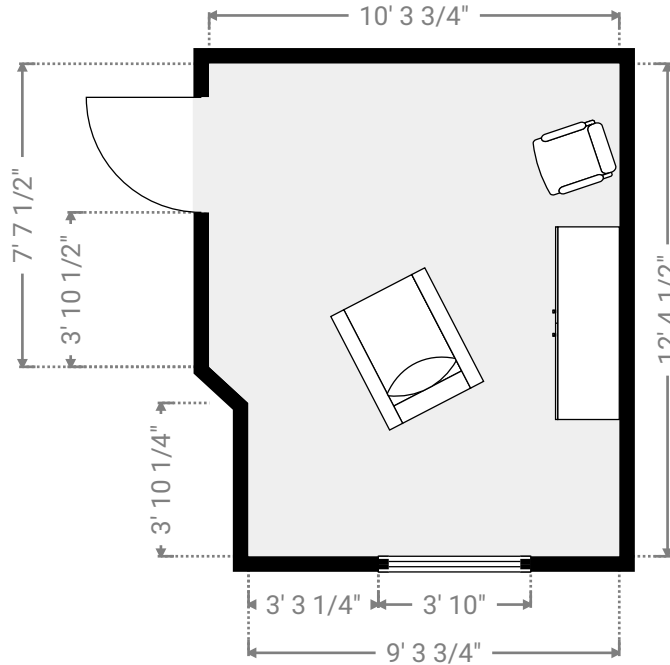
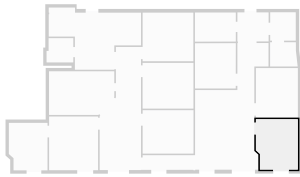

▼ Patient Room Ground Floor

WIDTH: 10' 1/2" • LENGTH: 11' 2" • CEILING HEIGHT: 9' 1/2"
AREA: 111.68 sq ft • PERIMETER: 42' 4"

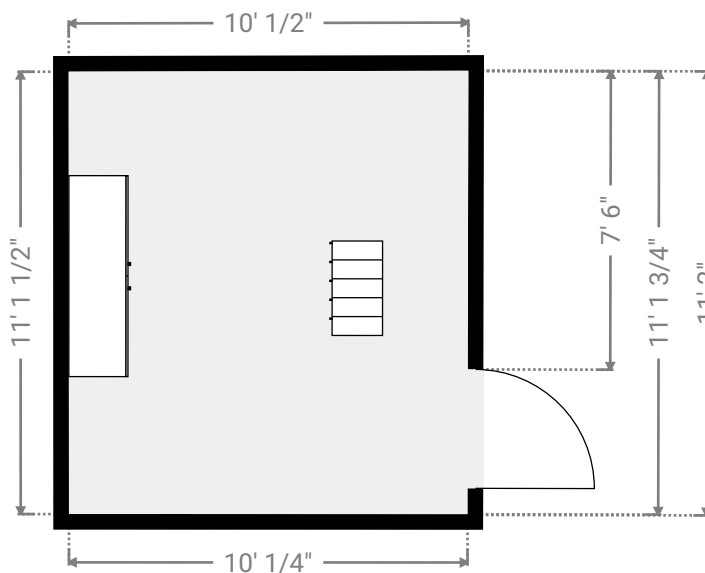
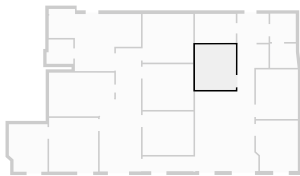

THIS FLOOR PLAN IS PROVIDED WITHOUT WARRANTY OF ANY KIND. SENSOPIA DISCLAIMS ANY WARRANTY INCLUDING, WITHOUT LIMITATION, SATISFACTORY QUALITY OR ACCURACY OF DIMENSIONS.



5266 Office Park Blvd

5266 Office Park Boulevard, 34203 Bradenton, Florida, US
TOTAL AREA: 2665.41 sq ft • LIVING AREA: 2665.41 sq ft • FLOORS: 1 • ROOMS: 19



▼ Patient Room Ground Floor

WIDTH: 10' 1" • LENGTH: 7' 2" • CEILING HEIGHT: 9' 1/2"
AREA: 71.96 sq ft • PERIMETER: 34' 5"

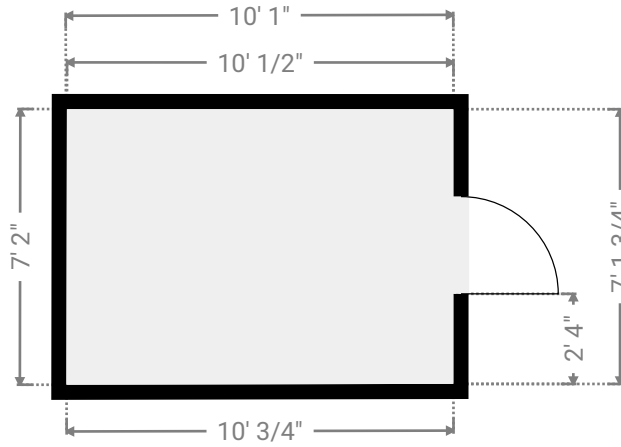
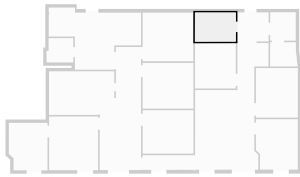

▼ Physician Office Ground Floor

WIDTH: 9' 6" • LENGTH: 11' 8" • CEILING HEIGHT: 9' 1/2"
AREA: 106.95 sq ft • PERIMETER: 41' 8 3/4"

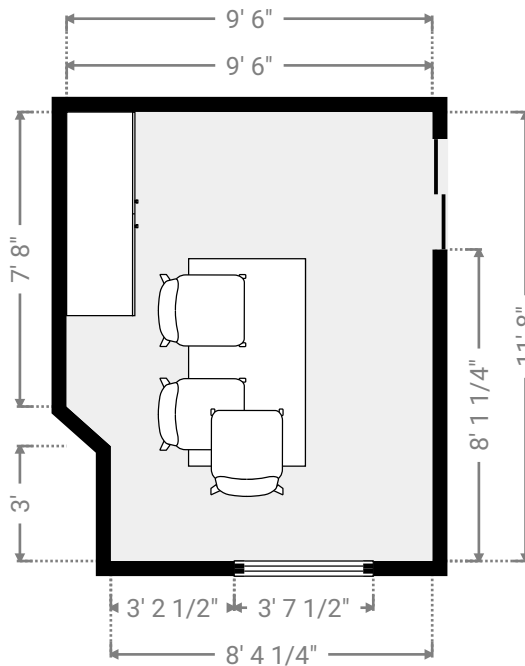
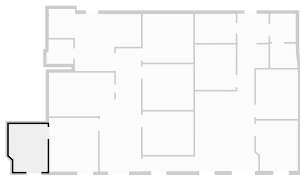

5266 Office Park Blvd

5266 Office Park Boulevard, 34203 Bradenton, Florida, US
TOTAL AREA: 2665.41 sq ft • LIVING AREA: 2665.41 sq ft • FLOORS: 1 • ROOMS: 19



▼ Primary Bathroom Ground Floor

WIDTH: 6' 3 1/2" • LENGTH: 6' 11 3/4" • CEILING HEIGHT: 10' 1 3/4"
AREA: 43.86 sq ft • PERIMETER: 26' 6 1/4"

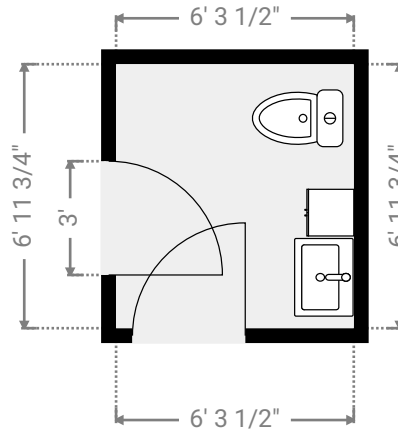
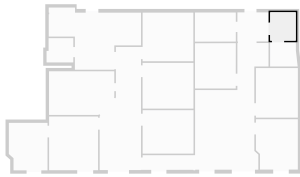

▼ Surgical suite Ground Floor

WIDTH: 16' 3/4" • LENGTH: 10' 8 3/4" • CEILING HEIGHT: 9' 1/2"
AREA: 163.64 sq ft • PERIMETER: 51' 1 3/4"

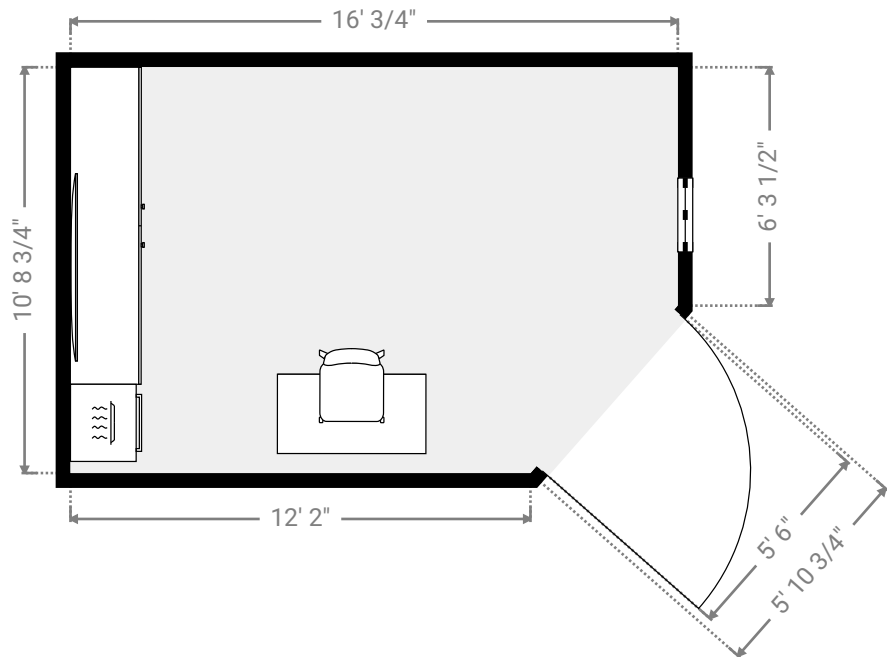
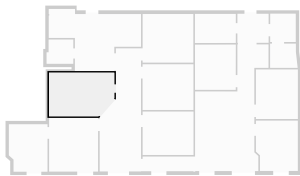

THIS FLOOR PLAN IS PROVIDED WITHOUT WARRANTY OF ANY KIND. SENSOPIA DISCLAIMS ANY WARRANTY INCLUDING, WITHOUT LIMITATION, SATISFACTORY QUALITY OR ACCURACY OF DIMENSIONS.

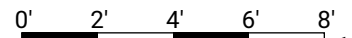

1:61

5266 Office Park Blvd

5266 Office Park Boulevard, 34203 Bradenton, Florida, US
TOTAL AREA: 2665.41 sq ft • LIVING AREA: 2665.41 sq ft • FLOORS: 1 • ROOMS: 19



▼ Toilet Ground Floor

WIDTH: 6' 1/2" • LENGTH: 7' 1 3/4" • CEILING HEIGHT: 10' 1 3/4"
AREA: 43.04 sq ft • PERIMETER: 26' 7"

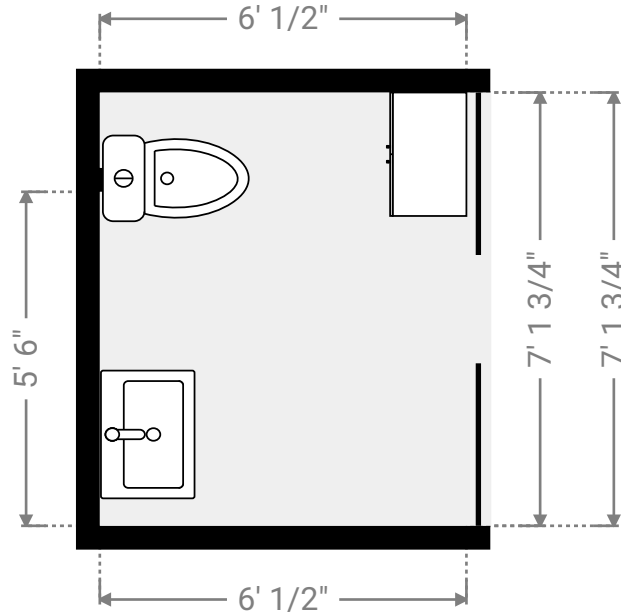

▼ Utility Room Ground Floor

WIDTH: 6' 6 3/4" • LENGTH: 5' 11 3/4" • CEILING HEIGHT: 10' 1 3/4"
AREA: 37.66 sq ft • PERIMETER: 25' 1"

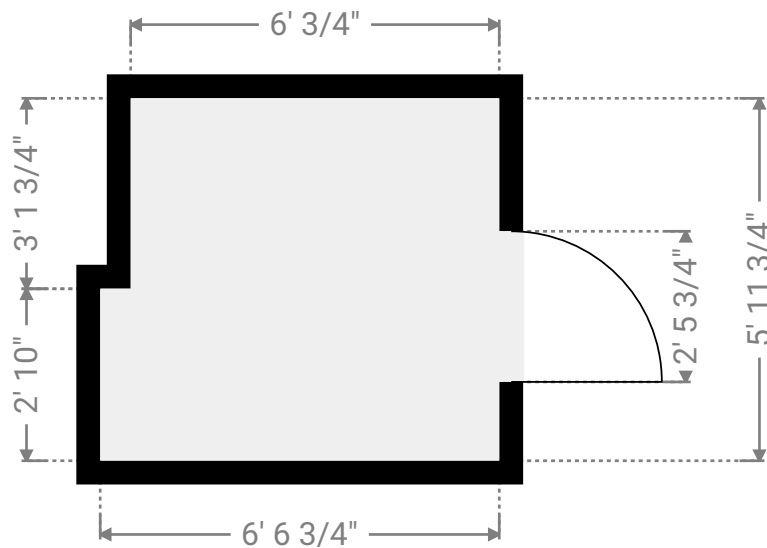
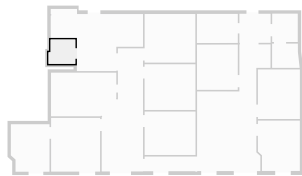

5266 Office Park Blvd

5266 Office Park Boulevard, 34203 Bradenton, Florida, US
TOTAL AREA: 2665.41 sq ft • LIVING AREA: 2665.41 sq ft • FLOORS: 1 • ROOMS: 19



▼ Utility Room Ground Floor

WIDTH: 6' 9 1/4" • LENGTH: 5' 11 1/2" • CEILING HEIGHT: 10' 1 3/4"
AREA: 38.66 sq ft • PERIMETER: 25' 3/4"

