

**PICKETT
SPROUSE**
COMMERCIAL
REAL ESTATE



A WEST & WOODALL COMPANY

Durham Multifamily Investment Opportunity

*107 & 109 Hilton Avenue,
Durham, NC 27707*

Well-Located 8-Unit Multifamily Investment in Central Durham

Located at 107 & 109 Hilton Avenue, this 8-unit multifamily property offers a well-positioned investment in one of Durham's established residential areas.



PROPERTY OVERVIEW

Property Details

PIN	0821-30-1226
REID	107677
ACREAGE	±0.65 acres
SQFT	±7,540 SF
COUNTY	Durham
ZONING	RS-8 (Residential Suburban-8)
PROPOSED ZONING (NEW UDO)	R-D (Residential Neighborhood)
UNITS	8
PRICE	\$1,200,000

The property totals approximately 7,540 square feet on ±0.65 acres and consists of two apartment buildings, each with four units—two on the first floor and two on the second.

All units are fully leased, with power separately metered, providing efficient operations for an owner. Recent improvements include new water heaters and select unit updates with refreshed flooring and fixtures.

Each building features garage space underneath, a valuable amenity for tenants. The central Durham location supports consistent rental demand and long-term stability, making this a solid opportunity for investors seeking a well-located, income-producing multifamily asset.

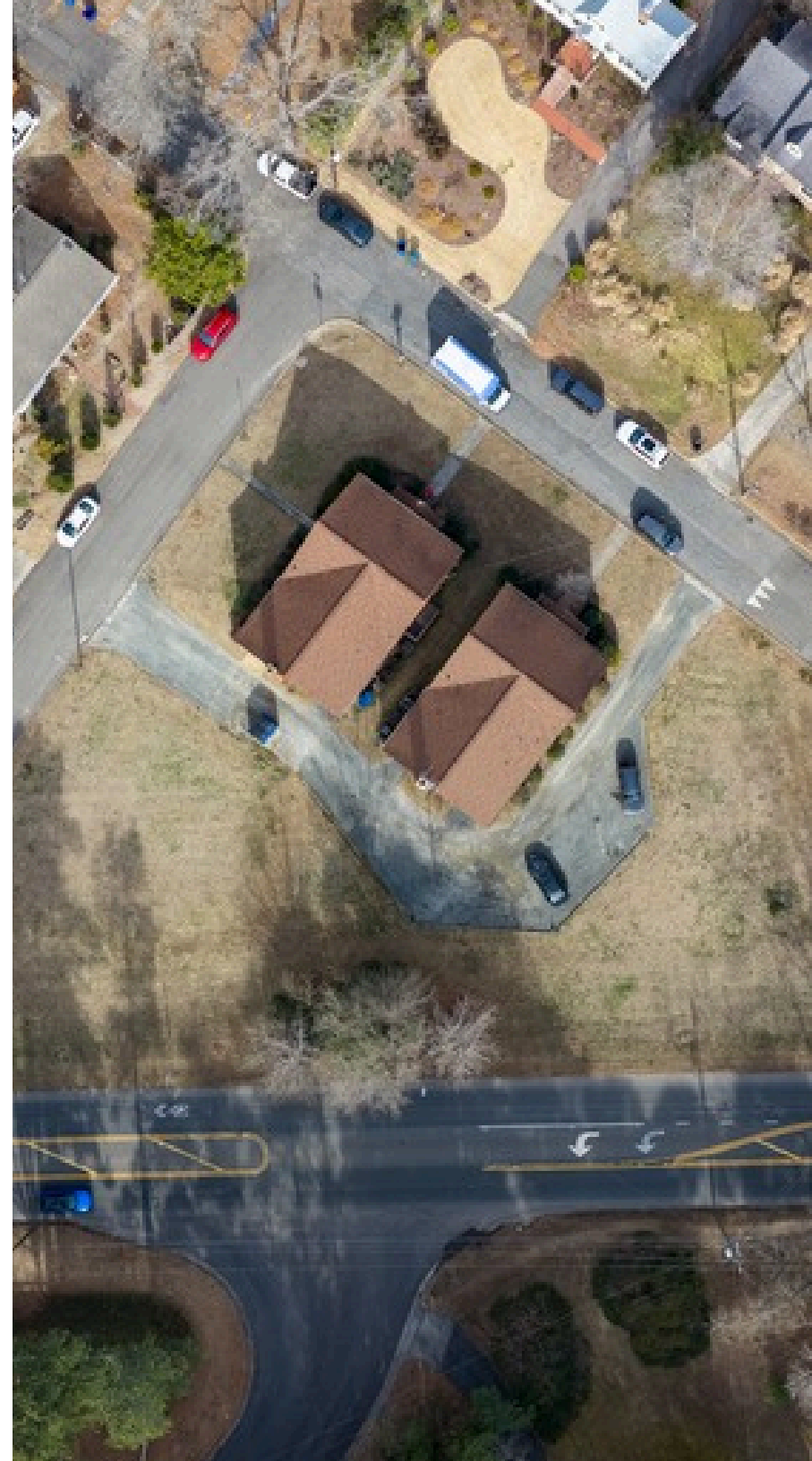

107 HILTON

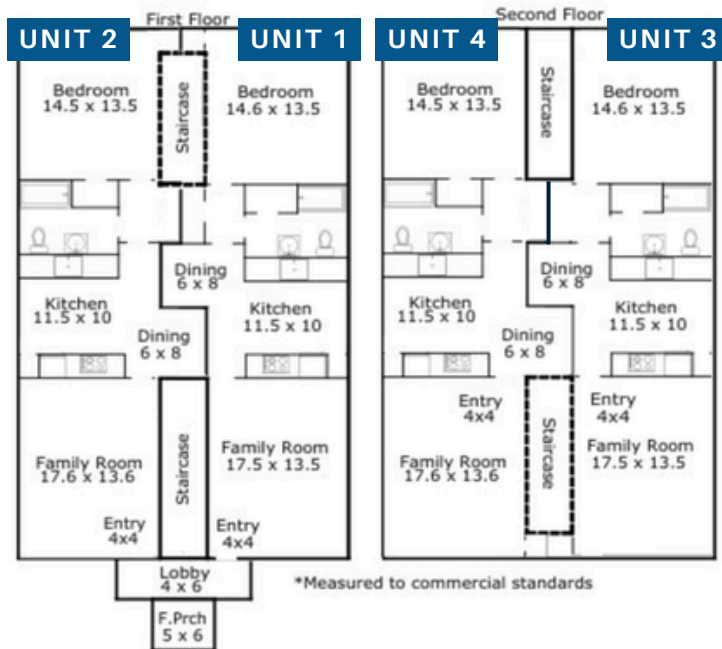
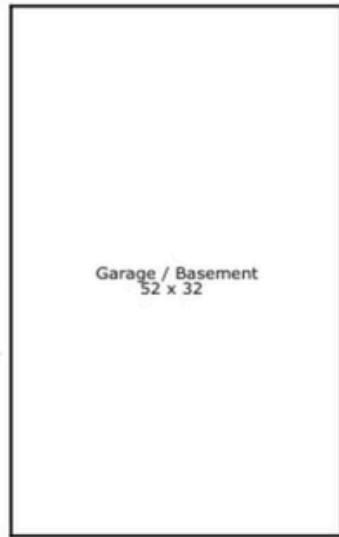

109 HILTON

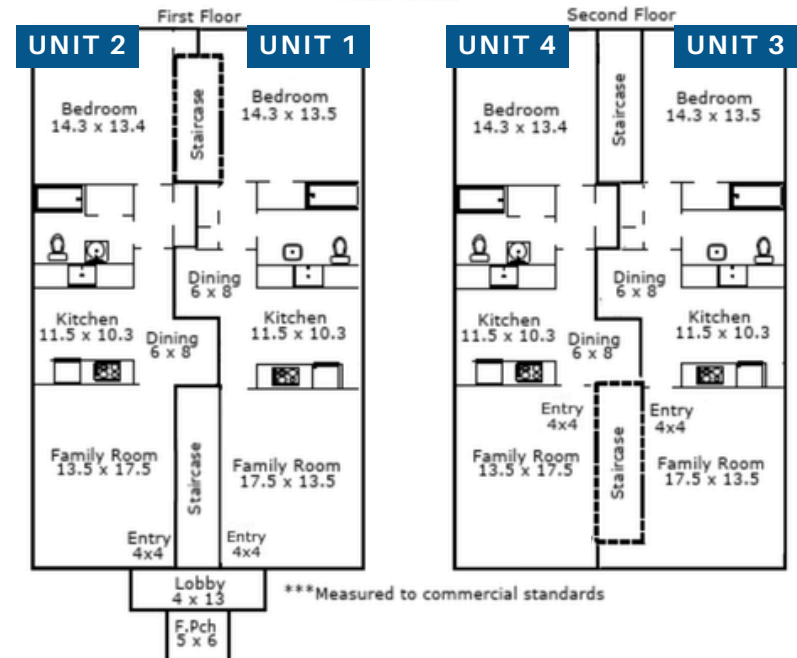
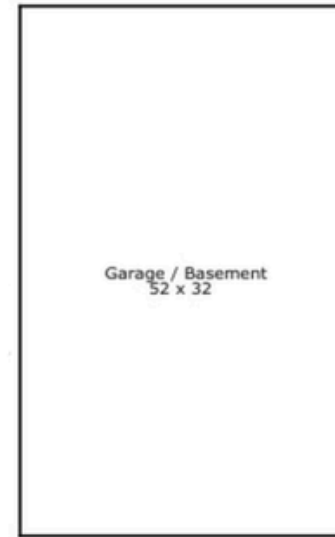

EXTERIOR PHOTOS



INTERIOR PHOTOS



LOCATION



LOCATION



SOUTH SQUARE

UNIVERSITY TOWER

		
		

LOCATION



LOCATION

DURHAM FREEWAY (147)	5 minutes
NC CENTRAL UNIVERSITY	6 minutes
DOWNTOWN DURHAM	7 minutes
DUKE UNIVERSITY & HOSPITAL	8 minutes
RTP	14 minutes
UNC CHAPEL HILL	16 minutes
DOWNTOWN CHAPEL HILL	18 minutes
RDU AIRPORT	22 minutes

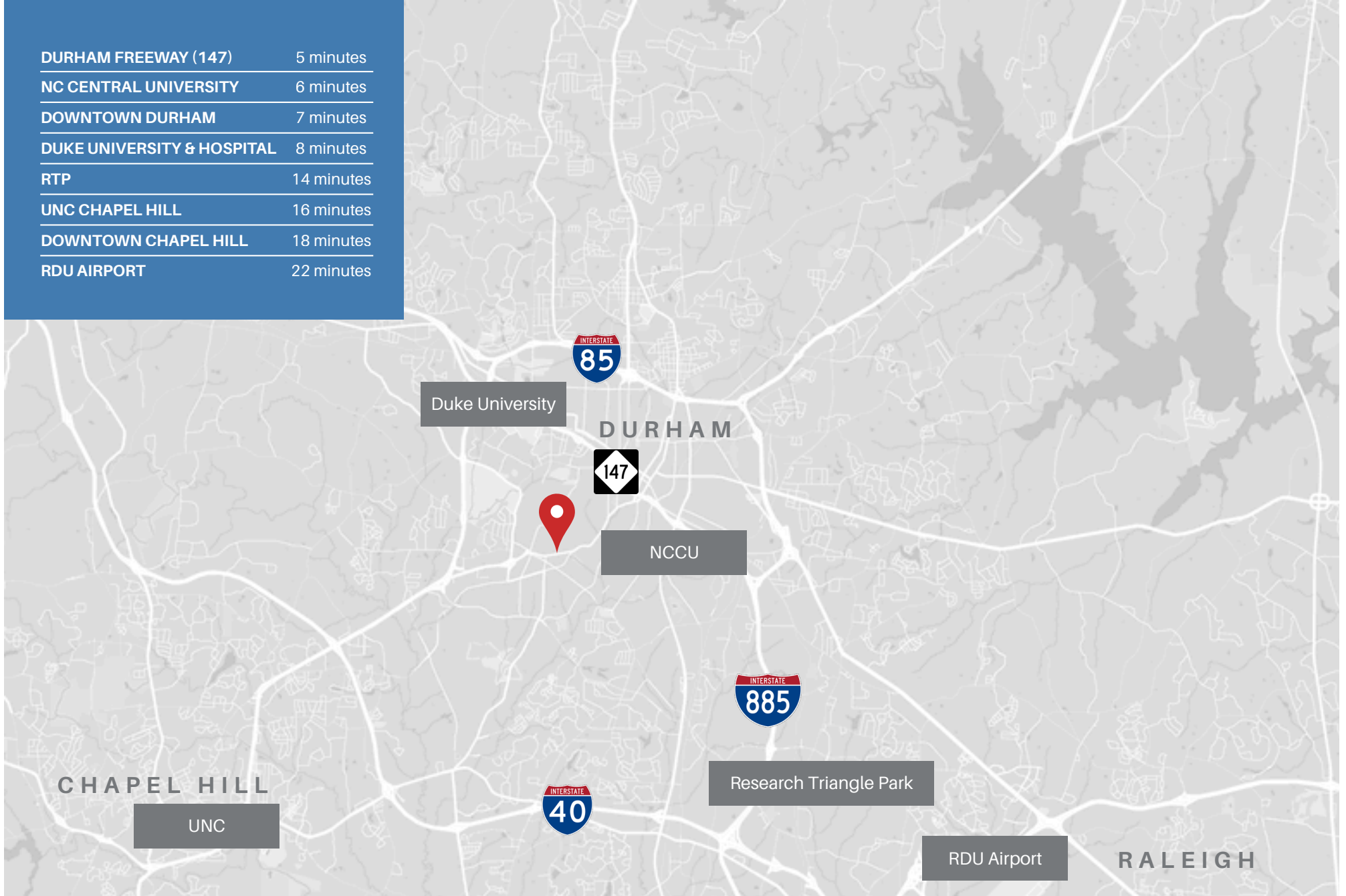

LOCATION

Population	1 mile	3 miles	5 miles
2020 Population	10,564	95,712	191,607
2024 Population	11,466	103,628	200,017
2029 Population Projection	12,089	108,808	209,011
Annual Growth 2020-2024	2.1%	2.1%	1.1%
Annual Growth 2024-2029	1.1%	1.0%	0.9%
Median Age	36.3	33.2	34.9
Bachelor's Degree or Higher	48%	46%	47%
U.S. Armed Forces	3	117	178

Households	1 mile	3 miles	5 miles
2020 Households	4,125	39,518	80,981
2024 Households	4,420	42,333	83,819
2029 Household Projection	4,661	44,644	87,839
Annual Growth 2020-2024	2.5%	2.3%	1.9%
Annual Growth 2024-2029	1.1%	1.1%	1.0%
Owner Occupied Households	2,221	15,335	35,076
Renter Occupied Households	2,440	29,308	52,763
Avg Household Size	2.3	2.1	2.2
Avg Household Vehicles	2	1	2
Total Specified Consumer Spending (\$)	\$134.2M	\$1.1B	\$2.3B



Pickett Sprouse Commercial Real Estate
(919) 493-0395

Contact Us

Brad Gregory
(336) 202-0012
brad@pickettsprouse.com

Matthew Morton
(919) 864-0864
matthew@pickettsprouse.com

pickettsprouse.com

